

Fitting Instructions #5600IS

BMW X5 2013-2018 – F15, F85

Control Arm Lower-Inner Bush (Front)

Note: Polyurethane bushes must be fitted to both sides of the vehicle.

- Jack the vehicle up and support on stands/hoist, remove the front wheels.
- Remove the lower shock bolt and inner bush bolt located in the chassis.
- On the knuckle side, remove the split pin and loosen the nut but do not remove. Then, break the taper between the ball joint stud and steering knuckle. Careful to not hit on the thread and boot.
- Remove the front lower control arm from the vehicle.
- Remove original bushings including the steel shell from the arm with the use of a hydraulic press and suitable pressing tools.
- Clean housing areas to remove any old original bushing material. Then, press the new bush marked '5600' into the housing. Ensure the bushes are installed central in the arm (equal both sides).
- Apply the grease supplied to the bore of the new polyurethane bushes and the outside of the steel crush tube. Then, press the crush tube into the bushes.
- Refit the front lower control arms to the vehicle and tighten all bolts to manufacturers torque settings.
- Wheel align the vehicle and check new settings. Re-check all bolts after 1000kms.

KIT CONTENT			
KIT No.	PART No.	DESCRIPTION	QTY.
SPF5600K	SPF5600	BUSHES BONDED	2
	SPF1237T	CRUSH TUBE (24 X 14.3 X 71)	2

Left Hand Side Shown

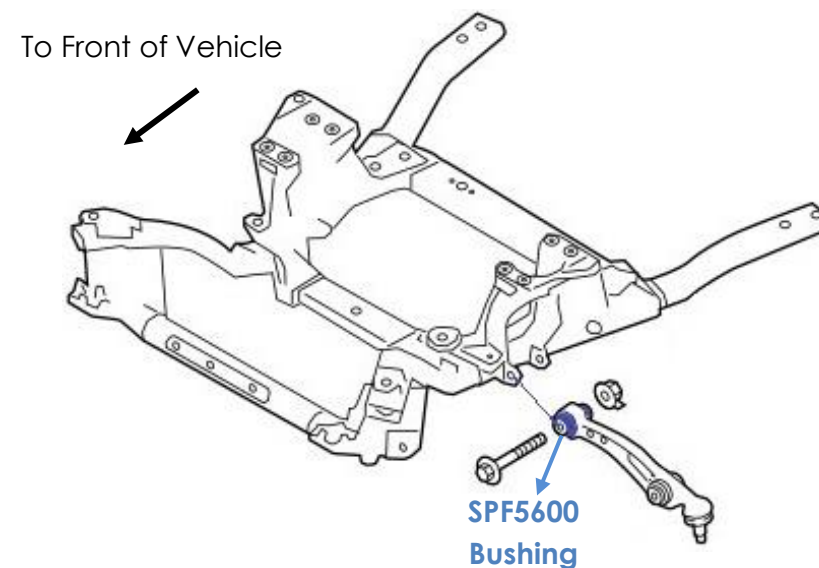

Figure 1: Front Suspension Arrangement

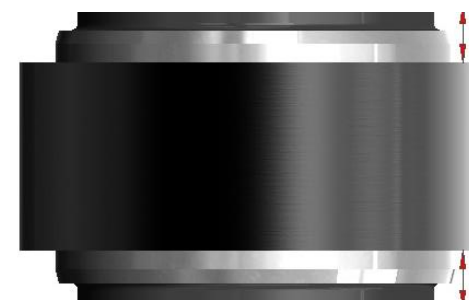

Figure 2: Bush positioning in housing