

# Fitting Instructions #5592IS

## Volkswagen Golf Mk7

### Control Arm Lower Rear Bushing (To Suit Alloy Subframe)



**Note:** Polyurethane bushings must be fitted to both sides of the vehicle.

- Wheel-align the vehicle before the job is started and note settings;
- Jack the vehicle up and support on jack stands;
- Remove the lower control arms, then remove original shell part from the housing with the use of a hydraulic press and suitable pressing tools;
- With reference to the diagrams and the settings required, align the bushing with the bracket so that the hole in the bushing is positioned to give the desired result;
- Apply the white grease supplied to the bore of the bush, the outside of the crush tube and the inside of the polyurethane spacers;
- Push in the crush tube and fit the polyurethane spacers;
- Refit the control arm to the vehicle. Tighten all bolts to manufactures torque settings;
- Carry out a wheel alignment.

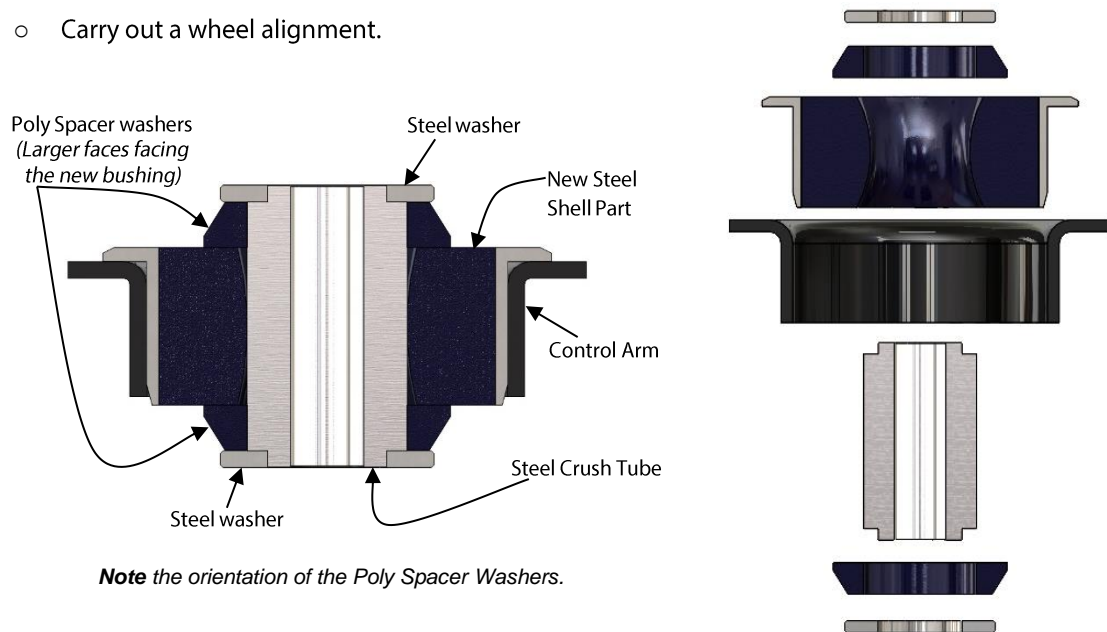

As viewed from the top of the control arm.

**Kit #5592K** – Standard Replacement. No caster change.

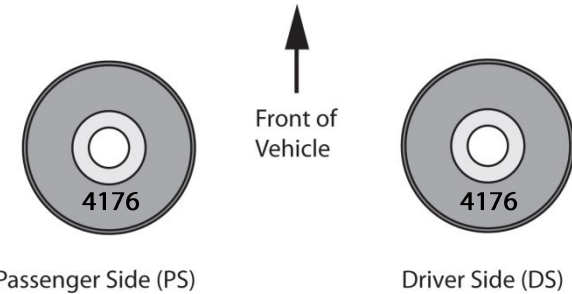

**Kit #5593K** – To counteract a slight pull to the left  
Single Offset, Passenger side caster increase (+0.5 degree).

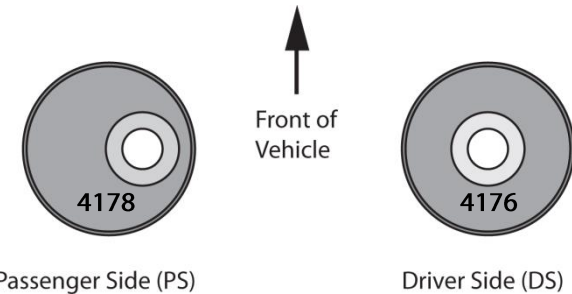

**Kit #5594K** – Performance Settings increase Caster both sides  
(+0.5 degree each side).

