

# Fitting Instructions #5538IS

## Mazda MX-5 ND

### Rear Hub Bushes



- Jack vehicle up and put on stands/hoist, remove rear wheels and the control arms/toe arm you are replacing;
- To remove the factory OE bushes without removing the hub, you could set the tools up according to the attached diagram and draw the bush out. Note excessive force is not necessary; make sure the spacers are lined up correctly. Also cover the bearing with a rag in case of failure, appropriate safety equipment must be used.
- Repeat process to install the new bush making sure the bush goes in straight;
- Apply the grease supplied to the bore of the bush and the outside of the crush tube and use a pair of multi grips to install the crush tubes;
- Refit control arms/trailing arms using manufactures torque settings and carry out a wheel alignment.

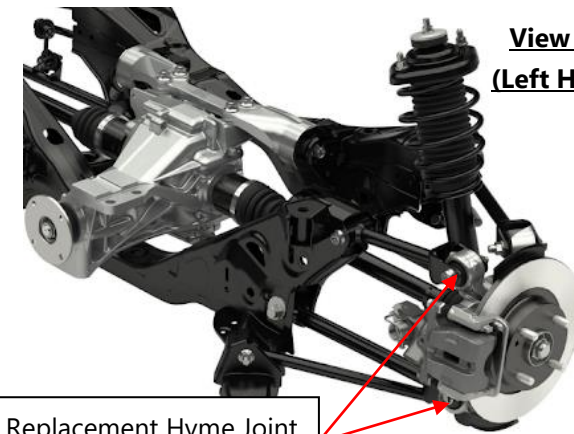

**View from Front End  
(Left Hand Side Shown)**

Replacement Hyme Joint  
(SPF5538K)

This procedure is only one option, alternatively you can remove the hub assembly and use a press to remove the bushes, **note** due to the awkward position of the rear toe control arm outer bush you may have to burn/cut out the bush depending on the press you have.

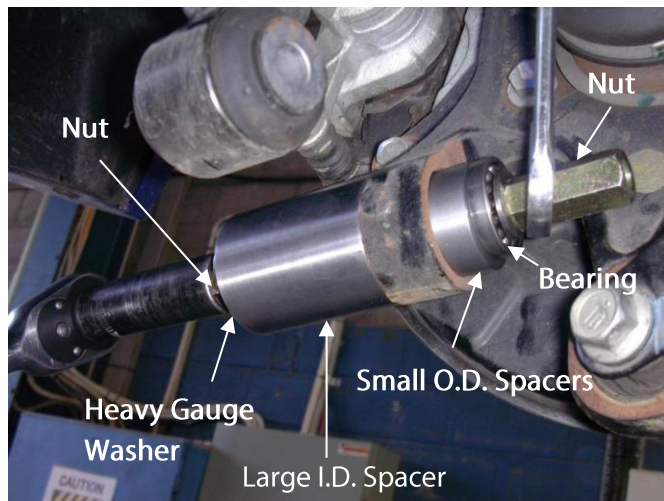

**View from Rear End  
(Left Hand Side Shown)**



Rear Control Arm Upper-Rear Outer Bush Kit (SPF5550K)

Rear Toe Control Arm Outer Bush Kit (SPF5551K)

Rear Control Arm Lower-Rear Outer Bush Kit (SPF5548K)