

Fitting Instructions #3806IS

BMW Z4 E89

Rear Control Arm Lower Outer Bushing

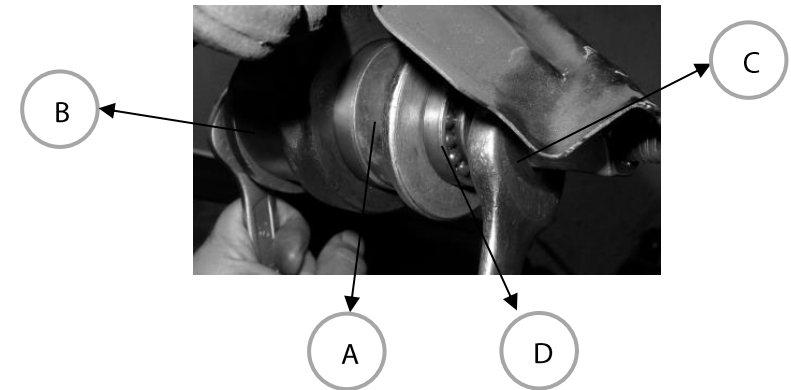
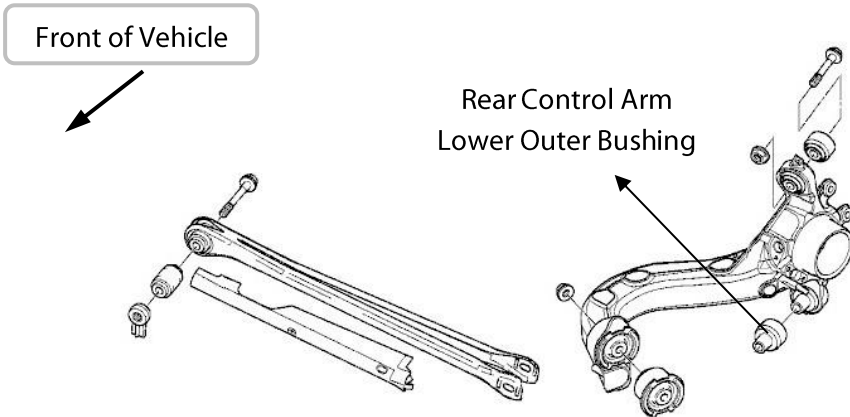

Note: Polyurethane bushes must be fitted to both sides of the vehicle.

- Jack the vehicle up and support on jack stands;
- Remove the rear wheels and the rear lower control arms to gain access;
- To remove the factory bush, you will need 1 x threaded rod and 2 matching nuts, (A) 1 x metal spacer where it's OD is slightly smaller than the ID/bore of the housing, (B) 1 x metal spacer where it's ID is slightly bigger than the ID/bore of the housing, (C) heavy gauge washers one to sit outside on each of the metal spacer, (D) old pinion style bearing, 2 matching spanners

- Clean housing areas to remove any old original bushing materials before installing new bushes;
- Install the new polyurethane shell part bushing in reverse order to the process of removing the factory bushing. Ensure that the bushings are set central.
- Lubricate the side faces of the new bushings and refit the rear lower control arm;
- Ensure that you tighten all fasteners to the manufacturer's specifications with the vehicle at ride height and get the vehicle wheel aligned