

Fitting Instructions #0746IS

Daihatsu Charade

Front Lower Control Arm Rear Bushing

Note: Polyurethane bushes must be fitted to both sides of the vehicle.

- Jack the vehicle up and support on jack stands/hoist and remove the front wheels;
- Remove:
 - The brake hose mounting bracket clip;
 - The hose from bracket;
 - The two strut mount bolts and separate bottom of strut from hub;
 - The two upper strut mount nuts;
 - The front strut assembly from the vehicle;
 - The strut rod retaining nut by using a suitable spring compressor. Note: this is a dangerous task and should only be performed by trained people.
- Drill out the spot welds with a $\text{Ø}5$ or $\text{Ø}6$ mm drill, Figure 1;
- Separate the upper part of the strut top from the bottom washer, Figure 2;
- Remove the original rubber bush and any left material;
- Apply the grease supplied onto all contact surfaces of the bush;
- Install the new bushing, Figure 2 and Figure 3;
- Re-fit the strut mount assembly and coil spring to the strut;
- Re-assemble all components back to the vehicle;
- Carry out wheel alignment.
- All mounting bolts are to be torque to manufacture's specifications with the vehicle at ride height.

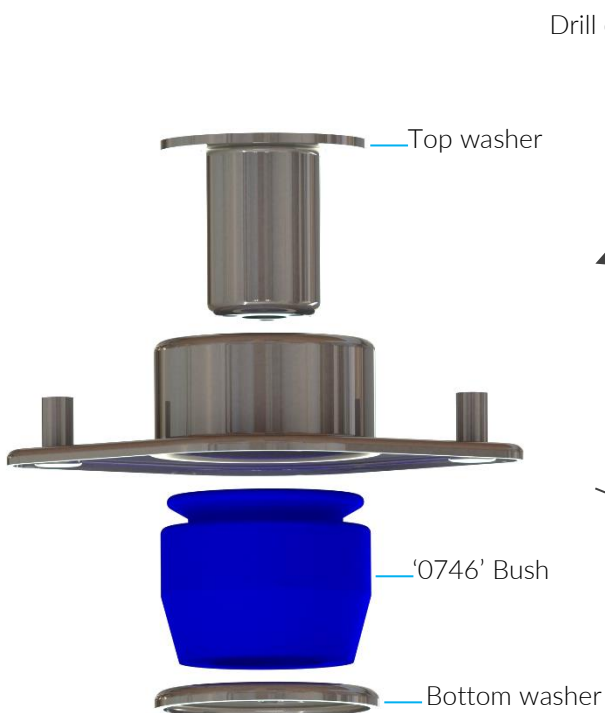

Figure 2 - Bush installation

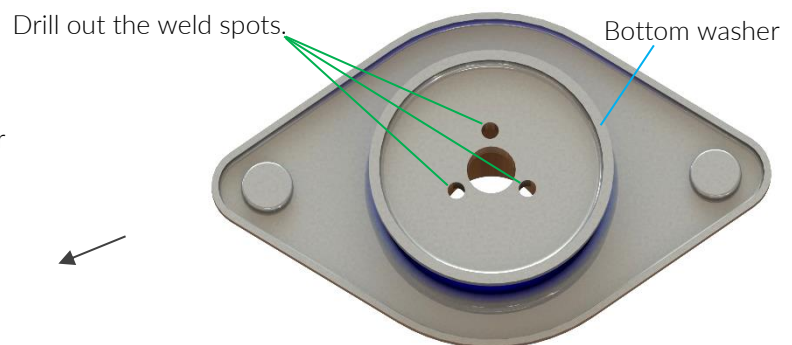

Figure 1 - Spot welds drilled out

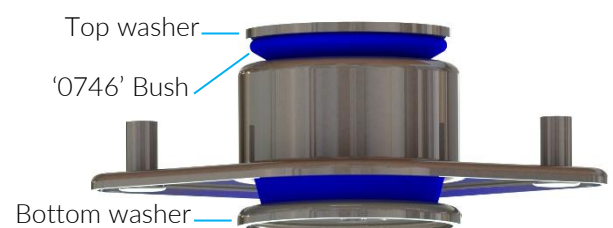

Figure 3 - New bushing installed