

Fitting Instructions #4330IS

BMW 3 SERIES E46

Rear Diff Mount Bushes replacement

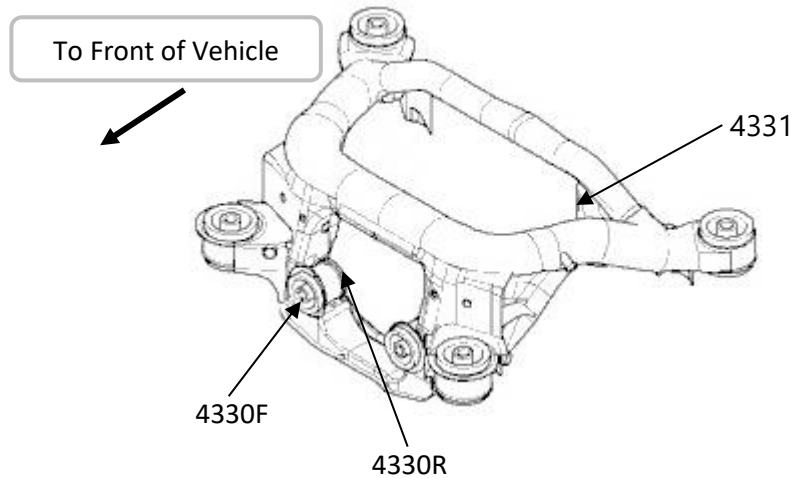

- Set the tools up according to figure below and draw the bushes out. Note excessive force is not necessary, make sure the metal spacers are lined up correctly. Also cover the bearing with a rag in case of failure, appropriate safety equipment must be used. **Note:** For the front mount, you could use Press Tool Kit No. 4 for location (A) and No. 8 for location (B). However, on the rear mount, you will need a custom spacer for location (A) but could use No. 12 on location (B).

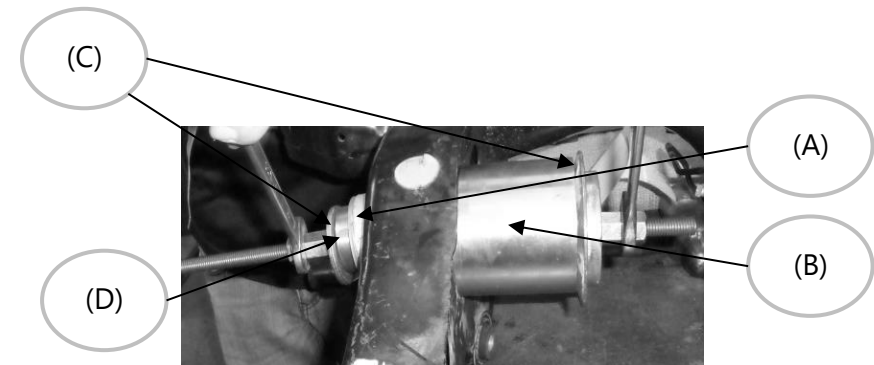

Figure 1: Tools setup for factory bushes

- Jack vehicle up and put on stands/hoist, remove rear wheels, exhaust pipe and the control arms/trailing arms that are attached to the sub frame;
- Remove the rear subframe and place it on separate jack stands then proceed to remove factory bushes;
- The factory diff mount bushes are shell parts. To remove the factory bushes you will need the following items (Refer to Figure 1): 1 x threaded rod and 2 matching nuts, (A) 1 x metal spacer where it's OD is slightly smaller than the ID/bore of the Diff mount housing, (B) 1 x metal spacer where it's ID is slightly bigger than the ID/bore of the Diff mount housing, (C) heavy gauge washers one to sit outside on each of the metal spacer, (D) old pinion style bearing, 2 matching spanners;

Fitting Instructions #4330IS

- Clean housing areas to remove any old original bushing materials before installing new bushes. Apply the grease supplied to the housing and the outside of the bush, then push the new bushes in with reference to the diagram alongside;
- To fit the crush tube into the bushes, apply the grease supplied to the bore of the bush and the outside of the crush tube and then, push it in. Use a pair of multi grips to aid installation of the crush tubes. **Note:** the bigger crush tube must be fitted into the rear mount and the smaller crush tubes to be fitted into the front mount;
- Note the orientation of the supplied washers in the diagrams alongside and tighten the bolts to manufacturer's torque settings.
- Repeat process to install the rest of the bush;
- Refit the rear subframe and all other suspension member to the vehicle ensuring that you use manufacturer's torque settings on all fasteners and carry out a wheel alignment.

Rear Diff - Rear Mount Installation (Right Hand Drive Shown)

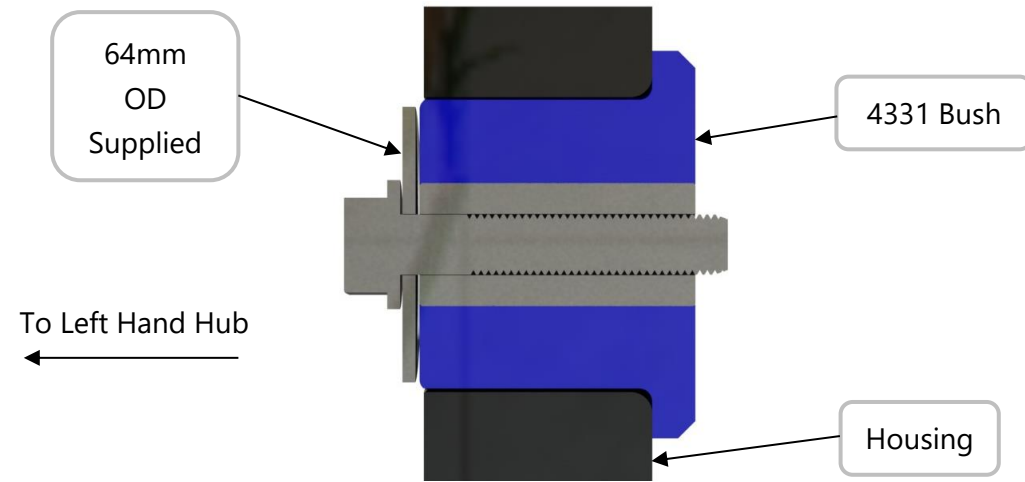

Rear Diff - Front Mount

