

Fitting Instructions #4529IS

Volkswagen Transporter T5

Rear Control Arm Lower Outer Bushing

- Wheel-align the vehicle before the job is started and note settings;
- Jack the vehicle up and support on jack stands/hoist and remove the lower control arms;
- Remove original shell part from the outer side housing of the arm with the use of a hydraulic press and suitable pressing tools;
- Apply the white grease to the outside surfaces of the bush and inside the housing;
- Push the new '4529' bushes into the outer housing according to the Figure 02;
- Apply the white grease supplied to the bore of the bush and outside of the crush tube, and then press it in, Figure 02.
- Apply the same procedure to the other control arm;
- Refit the control arms to the vehicle and tighten all bolts to manufacture's torque settings and carry out a wheel alignment.

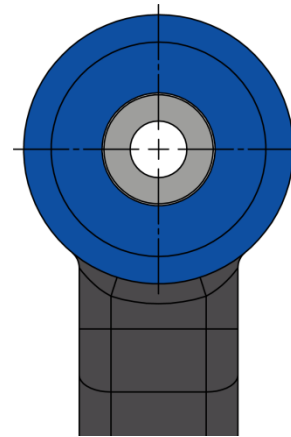

Figure 01 – RHS Control Arm Outer Side Front View

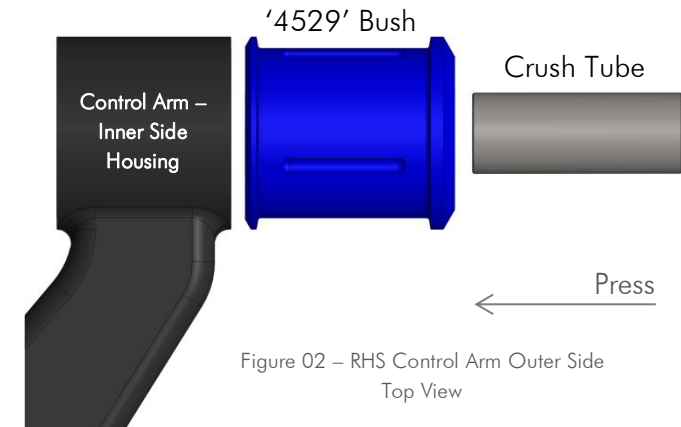

Figure 02 – RHS Control Arm Outer Side Top View

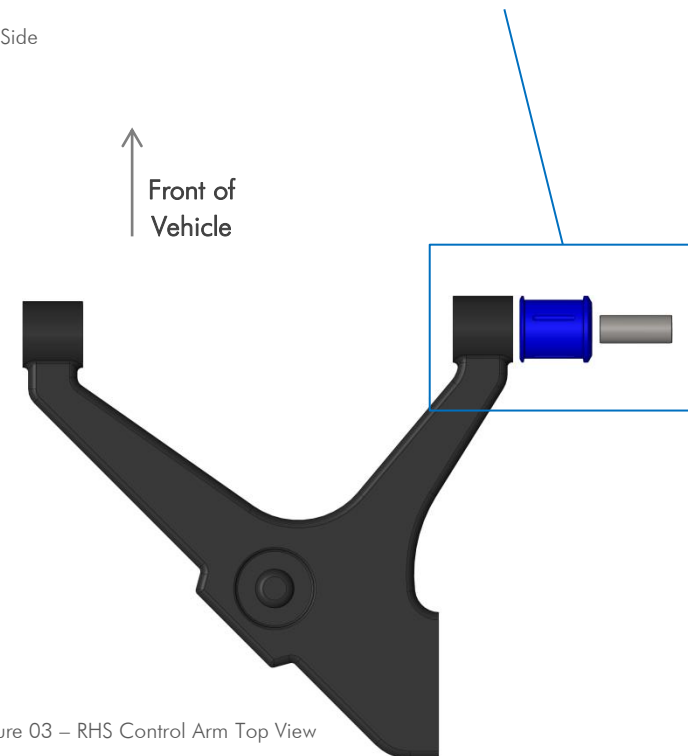

Figure 03 – RHS Control Arm Top View

Note: Polyurethane bushings must be fitted to both sides of the vehicle. This kit should be installed by a Qualified Motor Mechanic.