

Fitting Instructions #TRC480IS

Toyota Prado 120, 150 series / FJ Cruiser 2009 - On / Lexus GX 2009 - On
Adjustable Camber/Caster Upper Control Arms



1. Before beginning any alignment work, always check for loose or worn parts, correct tyre pressures, and odd tyre wear patterns. Replace any loose or worn parts before setting alignment.
2. Raise vehicle by the chassis and support with jack stands. Remove front tyre and wheel assemblies.
3. Loosen the nut on the upper arm-to-frame mounting bolt and remove bolt holding ABS wiring from upper arm.
4. Remove split pin and nut holding OEM ball joint to spindle. Break the taper between the ball joint stud and spindle and remove the ball joint from the spindle. Support the spindle so no strain is applied to ABS wiring or brake lines.
5. Remove the nut and washer from the long arm-to-frame mounting bolt and remove the bolt and arm.

Note: To provide clearance, additional components in the engine compartment may need to be removed.

6. Remove lower clip holding ABS cable to bearing assembly, taking care not to break clip.
7. Gently remove ABS cable from upper and lower bracket, slide supplied hose onto cable below where original insulation finishes.
8. Using supplied grease only, lightly coat the ends of the bushing.
9. Install the control arm to the vehicle.

The Arm is pre-assembled with the ball joint installed for maximum camber and castor change and torqued ready to install to the vehicle.

Note washer arrangement in the illustration:

For vehicles up to 50mm Lift - reuse the Toyota supplied washers in the original positions and add the supplied washers to the inside of the front and rear positions. See Figure 01.

For vehicles above 50mm Lift - reuse the Toyota supplied washers in the original positions and add both the supplied washers to the inside of the rear position only. See Figure 02.

Important: The Toyota supplied washers are cupped and should be installed as per Figure 01. Torque bolt-nut to 115 Nm.

Unlike bonded or rubber bushings, SuperPro bushings pivot freely and so can be torqued at full droop.

10. Insert the ball joint stud into the spindle, install the supplied castle nut and torque to 110Nm. Tighten further until the supplied split pin can be installed.
11. Re-attach ABS cable to lower bracket where additional hose was added to the ABS cable.
12. Re-attach lower bracket to upright using factory bolt.
13. Re-attach the ABS wiring bracket to the arm using supplied M8 bolt.
14. Check length of ABS cable, **ensure cable isn't too tight**, and clip cable back into the clip on the bearing assembly.
15. Re-install the tyre and wheel assembly. Lower vehicle and check for clearance and wheel align. Optimum camber, caster and set back can be set by the OEM lower control arm camber pins. It is advisable to not exceed more than - 0.75° Camber.
16. Note – The unique advantage of the SuperPro adjustable ball joint system, offers fine tuning of alignment settings or to make adjustments to achieve clearance on either the coil spring at full droop or the sidewall of oversize tyre and wheel packages at ride height. This is achieved by sliding the upper ball joint outwards on either or both sides. After adjustment re-tension ball joint nut to 143Nm.

Right Hand Side Arm Shown

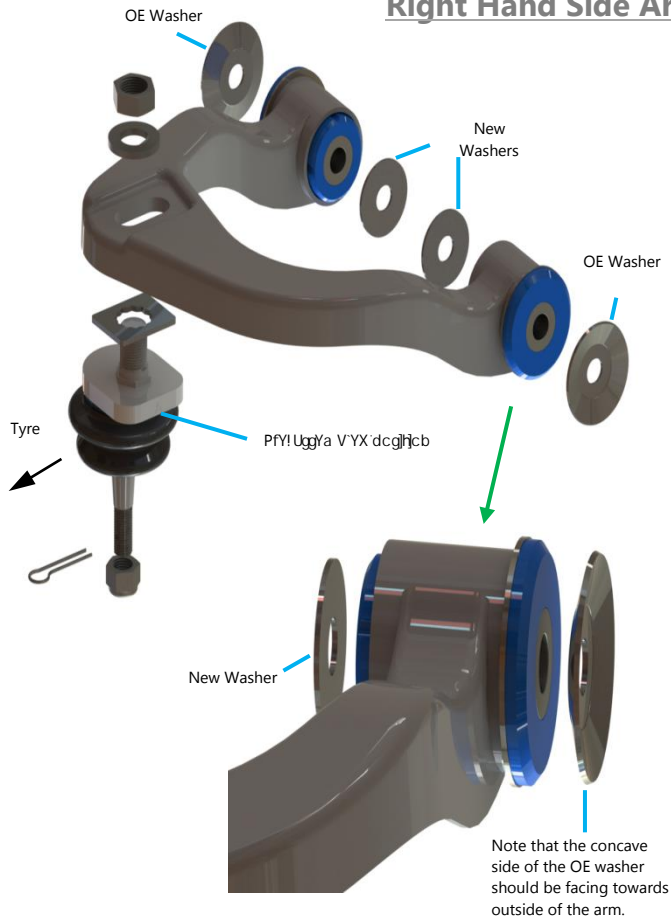

Figure 1 – Upper Control Arm installation

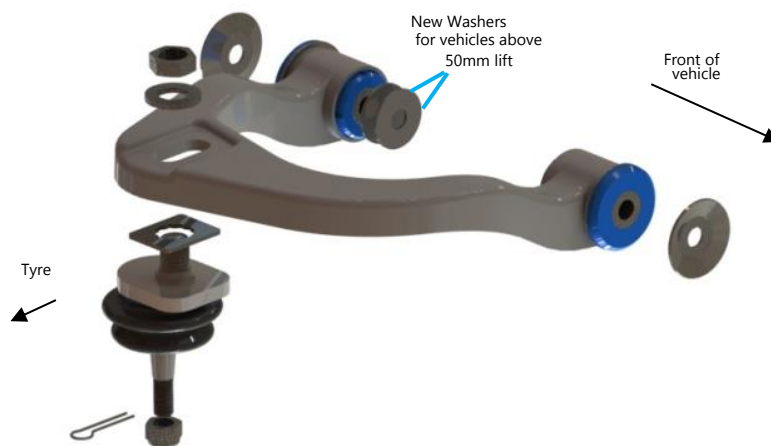

Figure 2 Upper Control Arm installation washer position above 50mm lift