

# Fitting Instructions #2910IS

Volvo S60, V70, V70XC

## Front Lower Control Arm Inner Rear Bushing

**Note:** Polyurethane bushes must be fitted to both sides of the vehicle.

- Support the vehicle on jack stands/hoist, remove the front wheels and remove the control arms from the vehicle;
- Remove original shell part from the control arms with the use of a hydraulic press and suitable pressing tools. Then press in the new polyurethane bush, Note the new bush will sit flush with the arm;
- Using the grease supplied, generously lubricate the outside of the steel tube, the polyurethane inside of the steel shell parts, and the inside of the polyurethane spacer washers. Push the steel crush tubes into the bushes. A hand press may be required to insert the steel tube, as there can be significant crush;
- Grease the faces of the polyurethane spacer washers, and push them onto the tubes. The spacers are to be arranged as depicted in the diagram below. (Larger face of spacers must face the new bushing);
- Refit the control arms with the new bushes and washers into the vehicle. Wheel align vehicle and check new settings.



SPF2910K Replaces O.E. Part 8630604 & 8630605 and contains:

- 2 x SPF2910 bushes.
- 2 x SPF2910T metal crush tubes.
- 4 x SPF2910A polyurethane spacers.

Fulcrum recommends you fit SPF2913K to the front lower control arm, front position, in conjunction with this kit to improve the balance of your car.

**Side view of assembled new part in control arm**

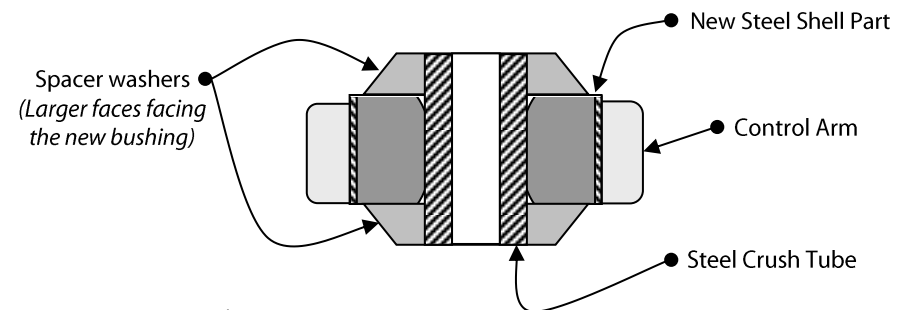

✓ **Note** the orientation of the Spacer Washers