

# Fitting Instructions #5076IS

BMW 1 SERIES E81, E82, E87 & E88 / BMW 3 SERIES E90, E91, E92 & E93

## Radius Arm to Chassis Bushing (Front)

**Note:** Polyurethane bushes must be fitted to both sides of the vehicle.

- Support vehicle on jack stands/hoist, mark left and right hand side radius arms, and then remove them from the vehicle;
- Remove original shell part from the radius arms with the use of a hydraulic press and suitable pressing tools;
- Clean housing areas to remove any old original bushing materials before installing new bushes. Apply the grease supplied to the housing and the outside of the bush, and then push the new bushes in. Note: it is recommended installing the bush with its shorter flange facing towards the rear of vehicle, see Figures 01 and 02;
- Using the grease supplied, generously lubricate the outside of the steel tube, the bore of the new bush. Press the new crush tube in and refit the radius arms with the new bushes into the vehicle. **Note:** The side of the crush tube with a flange **must** sit on the shorter flange of the bush, see Figure 02;
- Tighten all bolts ensuring that you use manufacturer's torque settings and wheel align vehicle.

Left Hand Side Shown

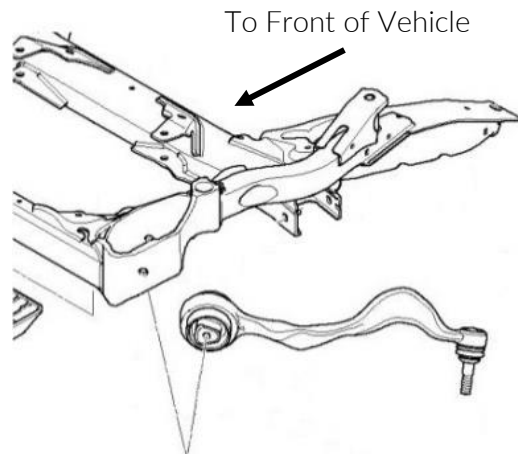

Figure 01 - Radius arm diagram

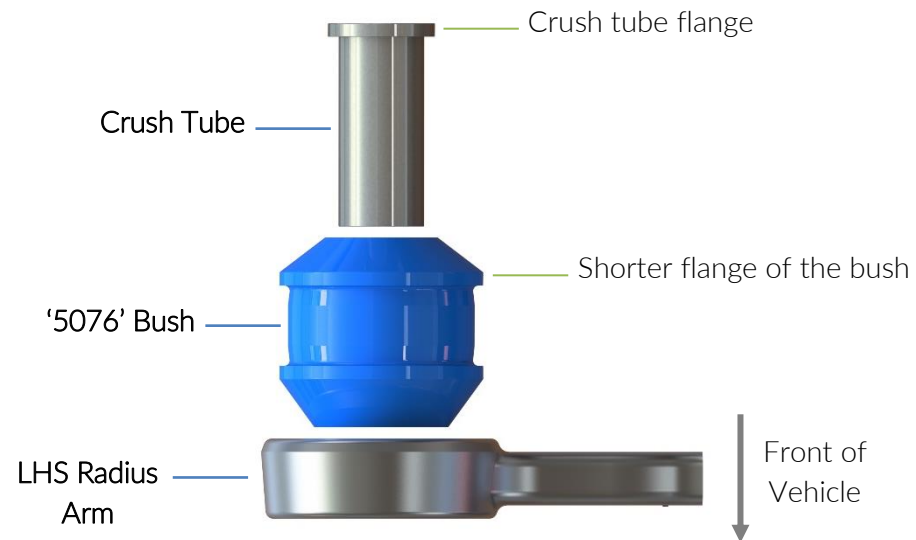

Figure 02 - Bush installation