

# Fitting Instructions #4894IS

## Chevrolet Corvette

### Rear Differential Bushing



- With the vehicle on jack stands/hoist, remove the rear differential;
- Remove original bushes with the use of a hydraulic press and suitable pressing tools;
- Clean housing surface to remove any old original bushing materials;
- Apply the grease supplied to the housing bore, outside and inside surfaces of the bushes and the outside of the steel crush tubes;
- Install the new bushes according to the Figure 01 ;
- Refit the rear differential to the car;
- Ensure that all fasteners are torque according to the 'General Torque Specification' table below or the manufacturer's settings, and carry out a wheel alignment.

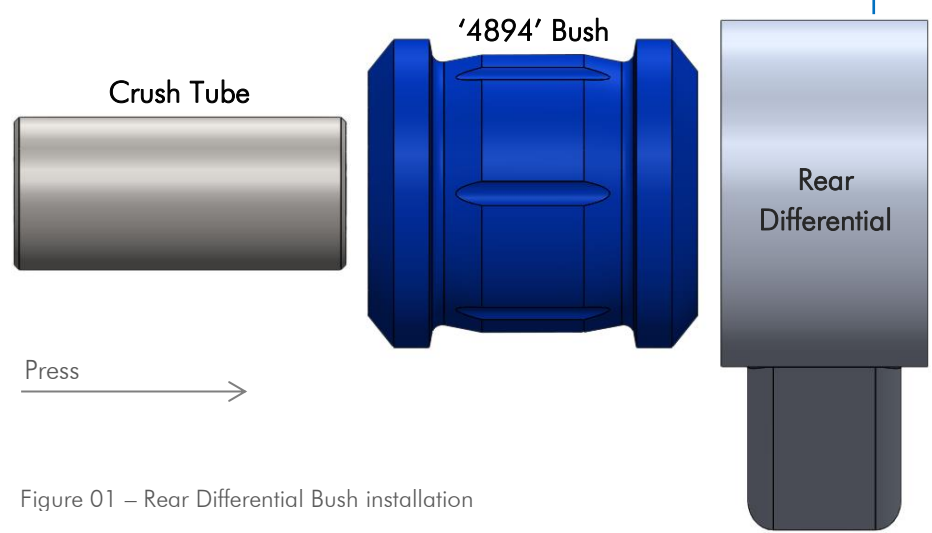
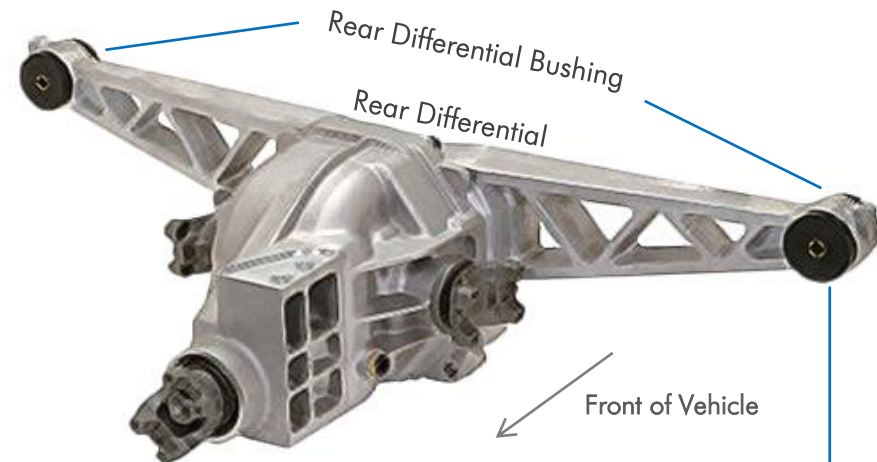

General Torque Specification								
Size	Class 8.8				Class 10.9			
	Lubricated		Dry		Lubricated		Dry	
	Nm	lb-ft	Nm	lb-ft	Nm	lb-ft	Nm	lb-ft
M10	43	32	55	40	63	47	80	60
M12	75	55	95	70	110	80	140	105
M14	120	88	150	110	175	130	225	165

Figure 01 – Rear Differential Bush installation