

Fitting Instructions #4260IS

Honda City, Jazz, Fit

Front Control Arm Lower Rear Bushing

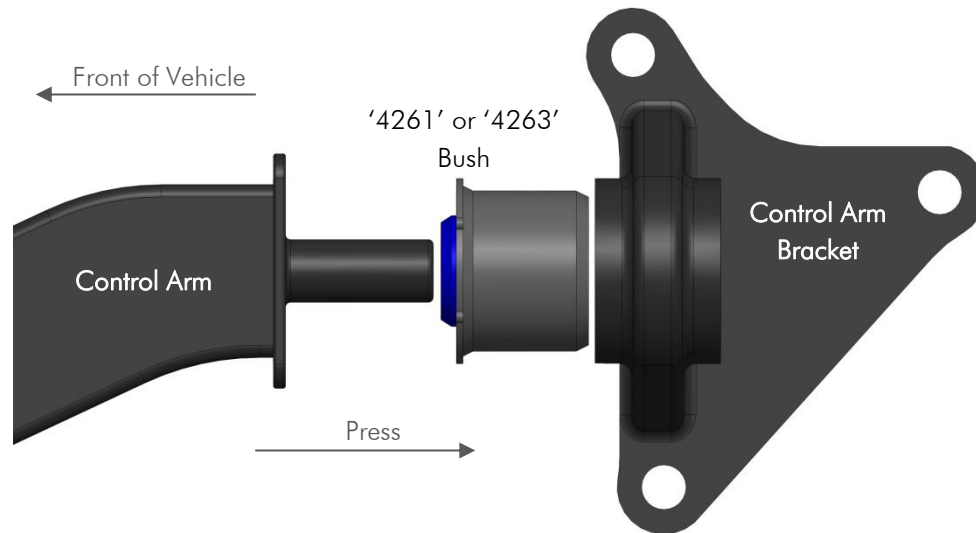

Note: Polyurethane bushings must be fitted to both sides of the vehicle.

- Wheel-align the vehicle before the job is started and note settings;
- Jack the vehicle up and support on jack stands/hoist;
- Remove the lower control arms;
- Remove original shell parts from the bracket housing with the use of a hydraulic press and suitable pressing tools;
- Using the grease supplied, lubricate the housing and outside diameter of the new bush and push it into the control arm bracket;
- With reference to the diagrams and the settings required, align the bushing with the bracket so that the hole in the bushing is positioned to give the desired result;

As viewed from the rear of the control arm.

Kit #4263K – Standard Replacement, no caster change

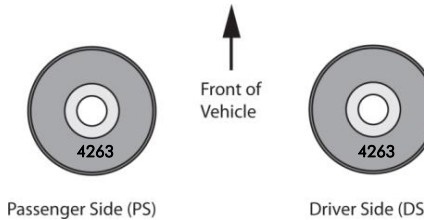

Kit #4260K – Single Offset, passenger's side caster increase (+0.5 degree)

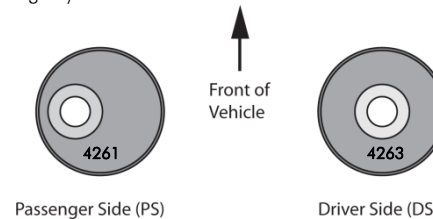

Kit #4261K – Performance Settings increase caster both sides (+0.5 degree each side)

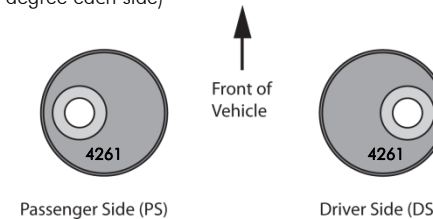

- Generously lubricate the outside of the control arm peg and inside of the bush, then push the control arm into the bush;
- Refit the control arms to the vehicle and tighten all bolts to manufacture's torque settings and carry out wheel alignment.