

Fitting Instructions #2782IS

Toyota MR2 3rd Generation, Yaris - Echo 1st Generation

Front Lower Control Arm Rear Bushing (To suit Right-hand drive vehicles)

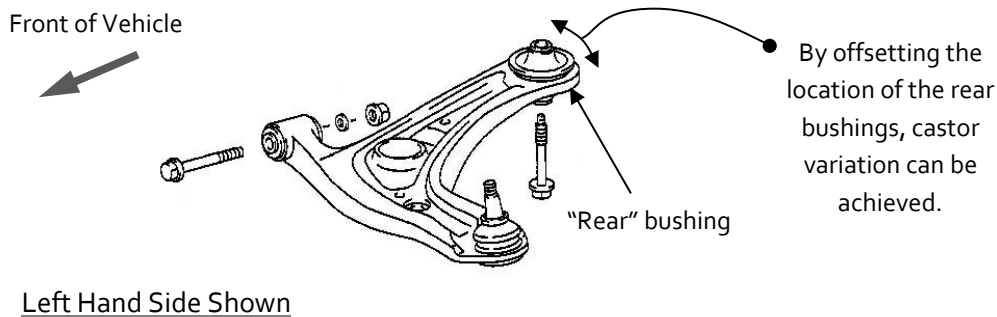

Note: Polyurethane bushes must be fitted to both sides of the vehicle.

- Wheel align the vehicle before the job is started and note castor settings;
- Remove the control arms from the vehicle;
- Remove original shell part from the control arms with the use of a hydraulic press and suitable pressing tools;
- **With reference to the diagrams, the kit number that you have purchased and the settings required, align the bushing in the control arms, so that the hole in the bushing is positioned to give the desired castor result;**
- Using the grease supplied, generously lubricate the outside of the steel tube, the polyurethane inside of the steel shell parts, and the inside of the polyurethane spacer washers. Push the steel crush tubes into the bushes. A hand press may be required to insert the steel tube, as there can be significant crush;
- Grease the faces of the polyurethane spacer washers, and push them onto the tubes. The spacers are to be arranged as depicted in the diagram below (Larger face of spacers must face the new bushing);
- Refit the control arms with the new bushes and washers into the vehicle;
- Wheel align vehicle and check new settings;
- All mounting bolts are to be tightened to manufactures specifications with the vehicle at ride height.

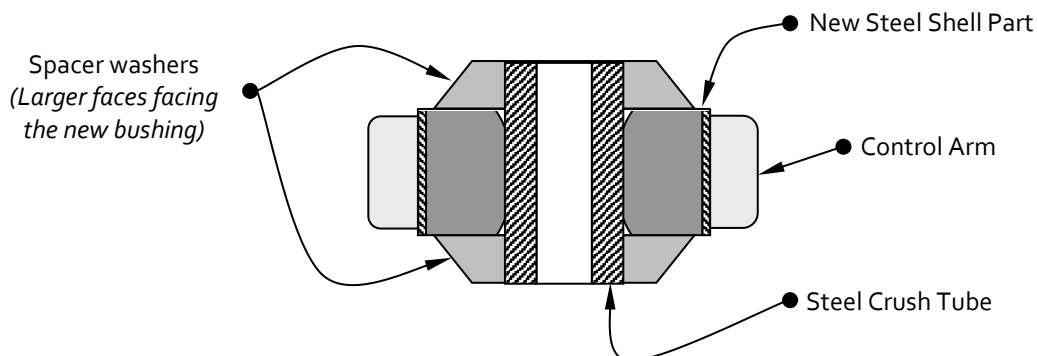

Note the orientation of the Spacer Washers

As viewed from the top of the control arm, looking down on rear bushing.

Kit #2782K – Standard Replacement (No caster change)

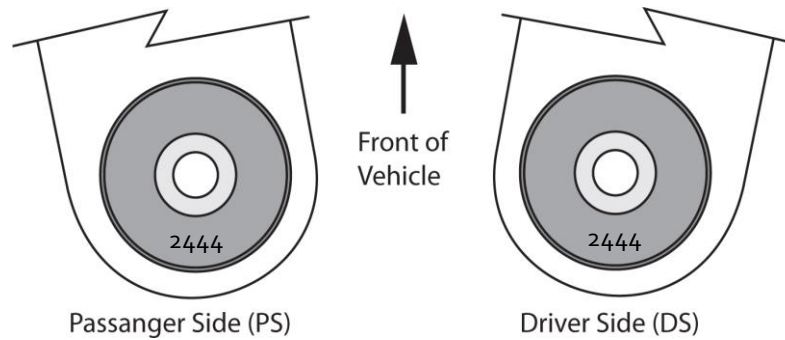

Kit #2797K – To counteract a slight pull to the left

Single Offset – Passanger side castor increase & drivers side no castor change.

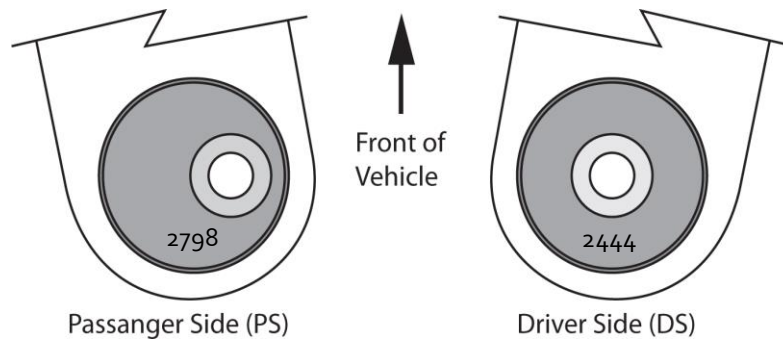

Kit #2798K – To counteract a strong pull to the left

Double Offset – Passanger side increase and driver side decrease castor.

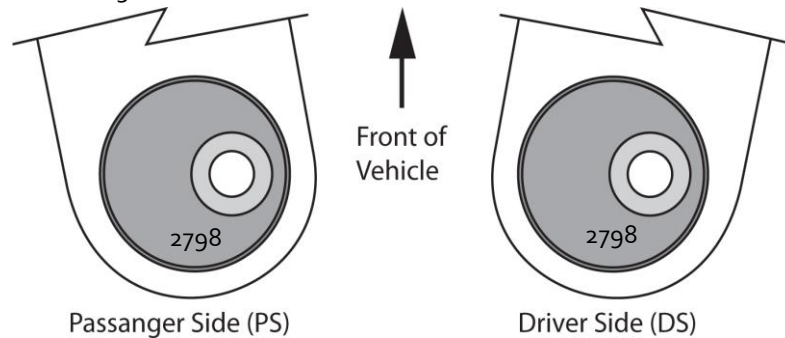

Kit #2798K – Performance settings

Double Offset – Passanger and driver side increase castor.

