

# Fitting Instructions #2100RIS

Hyundai / Kia

## Control Arm Lower Inner Rear Kit

Right Hand Side

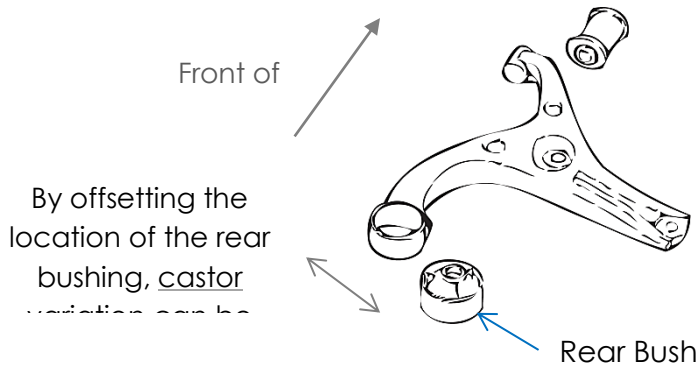

**Note:** Polyurethane bushings must be fitted to both sides of the vehicle.

- o Wheel-align the vehicle before the job is started and note settings;
- o Jack the vehicle up and support on jack stands;
- o Remove the lower control arms;
- o Remove original shell part from the housing with the use of a hydraulic press and suitable pressing tools, see Figure 01;
- o With reference to the Figure 02 and Table 01, align the bushing with the bracket so that the hole in the bushing is positioned to give the desired result;
- o Press the new '2100' and/or '2102' bushes into the control arm rear bush housing, Figure 02;

**Suggestion:** to install the new bushes, utilise the same tools that were used to remove the original bushes.

- o Apply the white grease supplied to the bore of the bush, the outside of the crush tube and the inside of the polyurethane spacers;
- o Push in the crush tube and fit the polyurethane spacers;
- o Refit the control arm to the vehicle. Tighten all

Use the press tool number 08 to remove the original bush from the control arm rear housing.

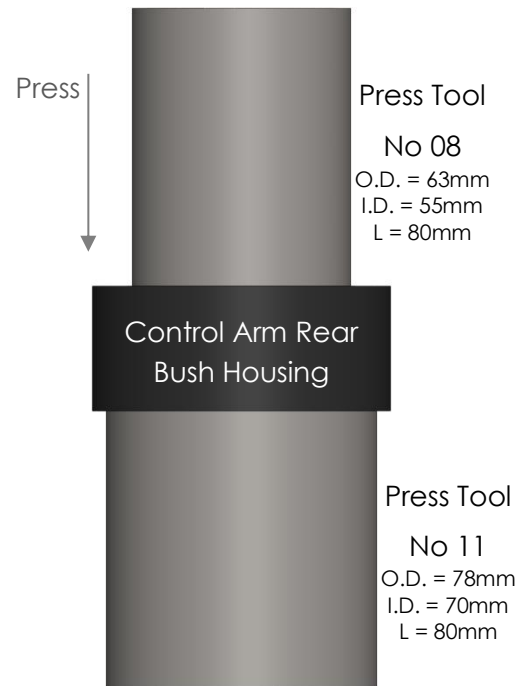

Use the press tool number 11 to support the control arm rear

Figure 01 – Original bush removal

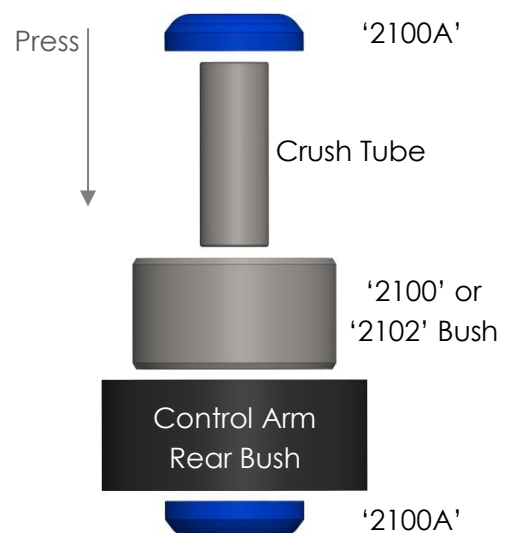

**Note:** the orientation of the

Figure 02 – Bush installation

Table 01 – Castor settings

As viewed from the top of the control arm.

**Kit #2100K** – Standard Replacement  
No castor change

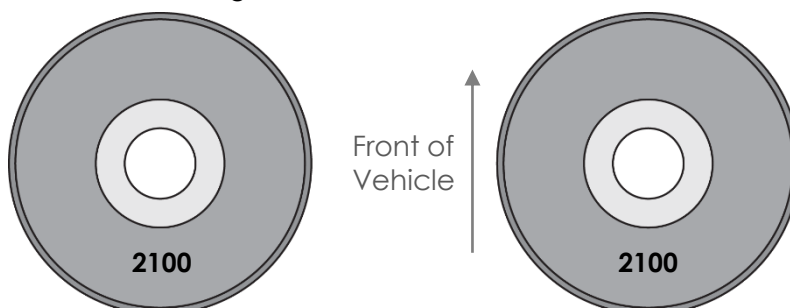

**Kit #2101K** – To counteract a slight pull to the left  
Single Offset, Passenger's side castor increase

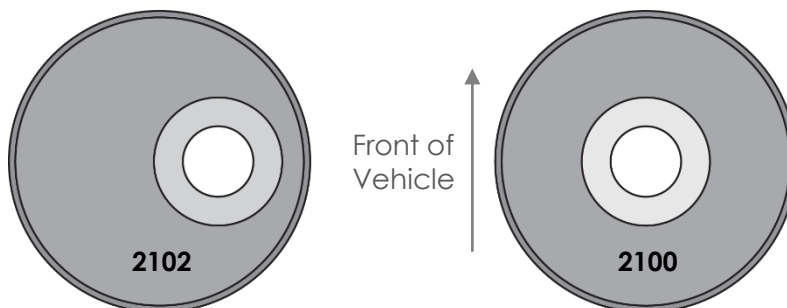

**Kit #2102K** – To counteract a strong pull left  
Passenger's side castor increase and driver's side castor decrease

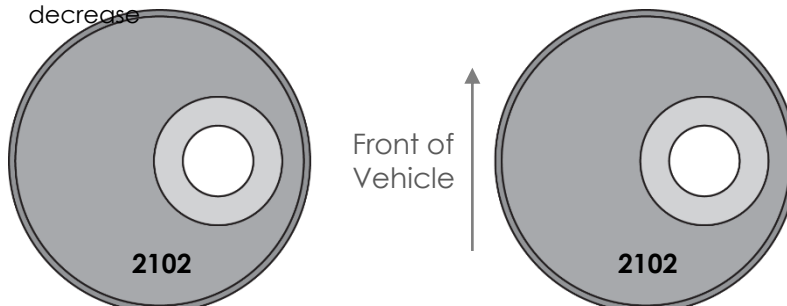

**Kit #2102K** – Performance Settings  
Increase castor on both sides

