

# Fitting Instructions #1313IS

## Mitsubishi Galant VR4

### Front Control Arm Lower Inner Rear Kit (SPF1313K, SPF1314K, SPF1315K, SPF1315AK)

**Note:** Polyurethane bushings must be fitted to both sides of the vehicle;

- Wheel-align the vehicle before the job is started and note settings;
- With the vehicle on a chassis hoist and wheels unsupported, remove underbody guards (and cross-brace if fitted) to allow access to mounts. Unbolt the lower control arm rear mount from the vehicle. Note the orientation of the bracket in the vehicle before removing.
- Remove the bushing from the arm, the arm can be pried down to help the removal of the bushing;
- With reference to the diagrams on page 2, and the settings required, align the bushing with the bracket and control arm so that the hole in the bushing is positioned to give the desired result;
- Using the supplied grease, grease the inside on the bushing and the outside of the control arm peg generously, before installing the bushing onto the control arm (Figure 1);
- Grease the outside on the bushing, then re-install the bracket to clamp the bushing to in place;
- Wheel-align vehicle and check new settings;
- Refit all cross-braces and guards which had been removed;
- All mounting bolts are to be torqued to manufactures specifications.

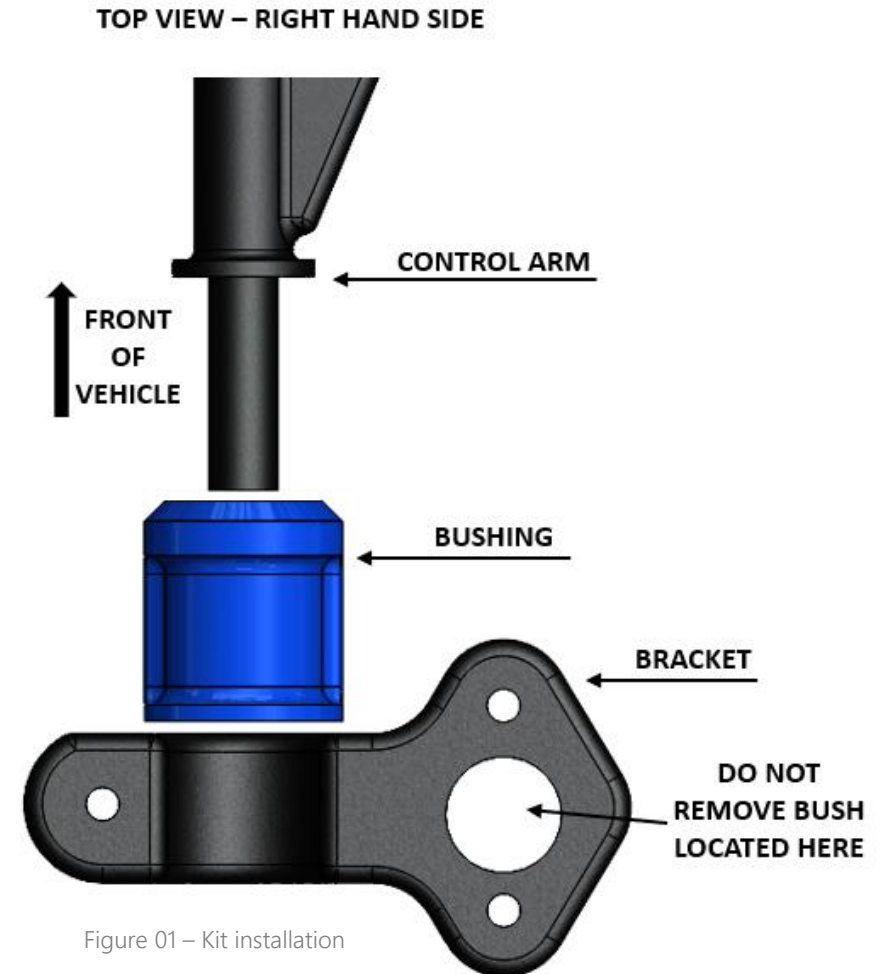

# Fitting Instructions #1313IS

**Kit #1313K – Standard Replacement**  
No Caster Change



**Kit #1314K – Single Offset Kit**  
Left hand side castor increase  
To correct pull to the left



**Kit #1315K – Double Offset Kit**  
LHS castor increase, RHS castor decrease  
To correct strong pull to the left

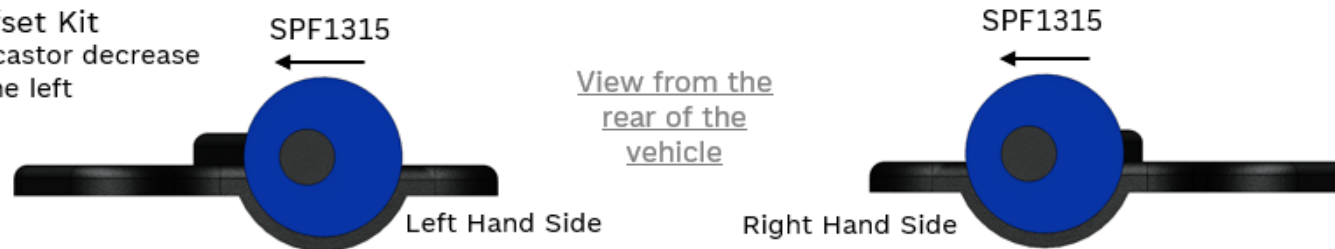

**Kit #1315AK – Double Offset Performance Kit**  
Castor increase to both sides

