

# Fitting Instructions #1944IS

## Hyundai Santa Fe

### Front Lower Control Arm Inner Rear Bushing (To Suit Right-Hand Drive Vehicles)

Note: Polyurethane bushings must be fitted to both sides of the vehicle;

- Wheel-align the vehicle before the job is started and note settings;
- With the vehicle on jack stands/hoist remove the front wheels and remove the lower control arms;
- Remove original shell part from the housing with the use of a hydraulic press and suitable pressing tools, take care to prevent stretching arm;
- With reference to the diagrams and the settings required, align the bushing with the bracket so that the hole in the bush is positioned to give the desired result;
- Press the bushes into the housing;
- The crush tubes can now be fitted to the bushes. A generous amount of the white grease supplied must be applied to both the bore of the bush and the outside of the crush tube;
- Fit the spacers supplied over the crush tubes top and bottom, use the white grease supplied to lubricate the spacers;

- Wheel-align vehicle and check new settings;
- Tighten all bolts according to the 'General Torque Specification' table or to manufacture's torque settings and carry out a wheel alignment.

General Torque Specification								
Size	Class 8.8				Class 10.9			
	Lubricated		Dry		Lubricated		Dry	
	Nm	lb-ft	Nm	lb-ft	Nm	lb-ft	Nm	lb-ft
M12	75	55	95	70	110	80	140	105
M14	120	88	150	110	175	130	225	165

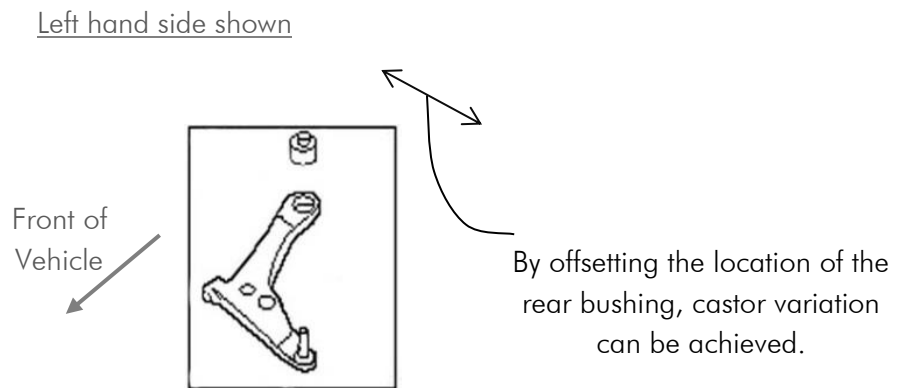

# Fitting Instructions #1944IS

As viewed from the top of the control arm

**Kit #1944K** – Standard Replacement  
No castor change.

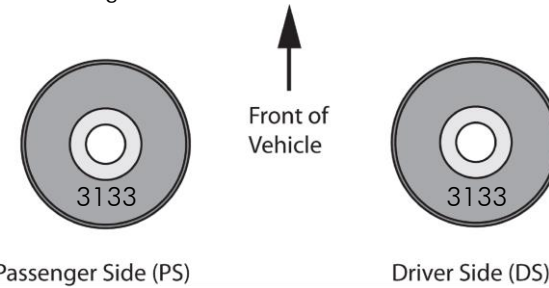

**Kit #1945K** – To counteract a slight pull to the left  
Single Offset, Passenger side castor increase (+0.5 degree)

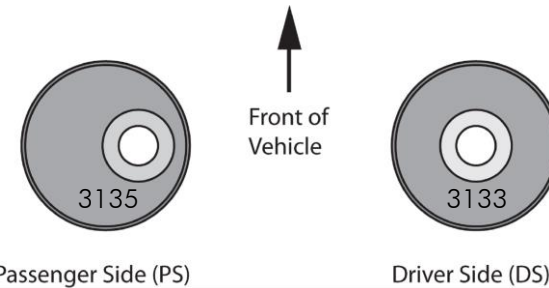

**Kit #1946K** – To counteract a strong pull left  
Double Offset, passenger +0.5 degree and driver -0.5 degree

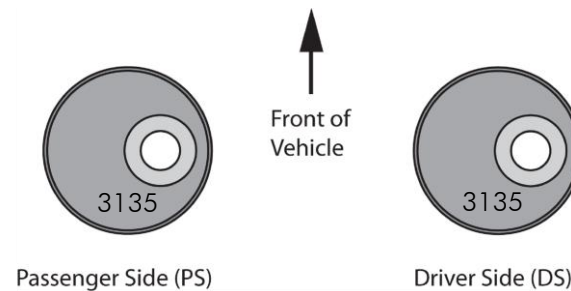
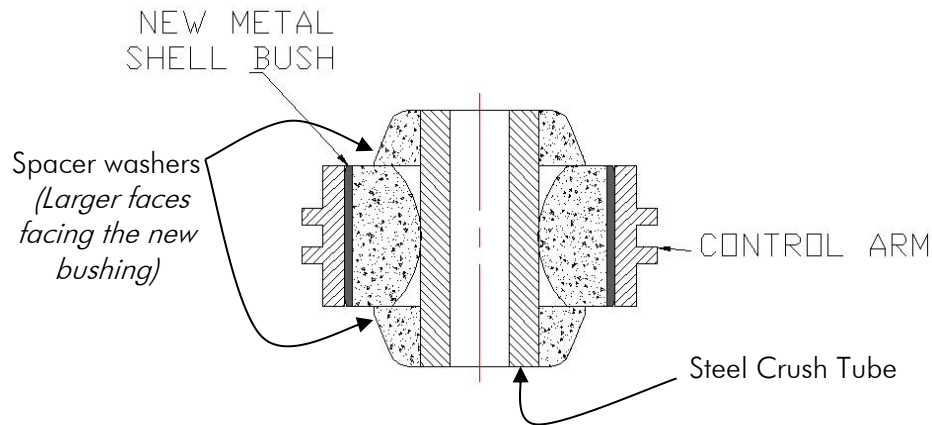

Table 1: Illustration of Castor Settings



*Note the orientation of the Spacer Washers.*