

# Instructions

## Front Strut Tops - Complete with Caps

**NOTE:** These components must be fitted by qualified persons only, to factory specifications, as per the factory service manual. Photos are an indication and may vary slightly in appearance from the actual product

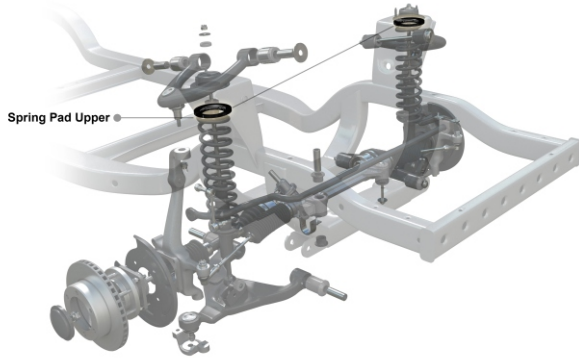

**Application** - Holden Colorado RG  
 - Isuzu D-max TF  
 - Mazda BT-50 TF  
 - Toyota Prado 90

*Always refer complete catalogue listing*

**Contents** - bushing 68200 x1  
 - bushing 68201 x1  
 - bushing 68202 x1  
 - steel top x1  
 - M10 x 1.25 nuts x3  
 - flat washer 40x12x3 x2

- Raise vehicle evenly and safely support.  
*Never rely on a jack only*
- Proceed to disconnect upper control arm ball joint. Complete removal of the arm may be necessary to remove the strut.
- Next, un-bolt complete strut from vehicle. Note orientation of the 3 studs verse the wheel . This will help with re-fitting strut to vehicle. Note below LH image.
- Compress the spring to remove the upper top. Fit up new top with new shock bushings and spring pad. Re-use OE upper shock nut.

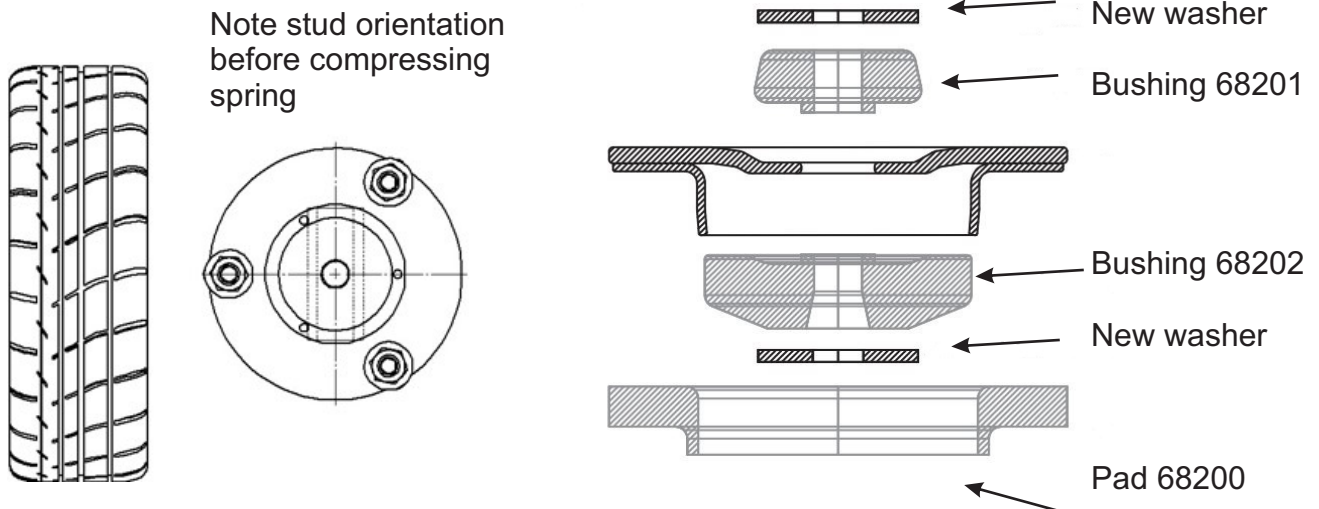

It is recommended that a licenced workshop or trades person carry out the above procedure and that workshop manual and relevant safety procedures are followed in addition to the above.