

Right Hand Side D-bush Assembly.
Note swaybar is in front of bracket

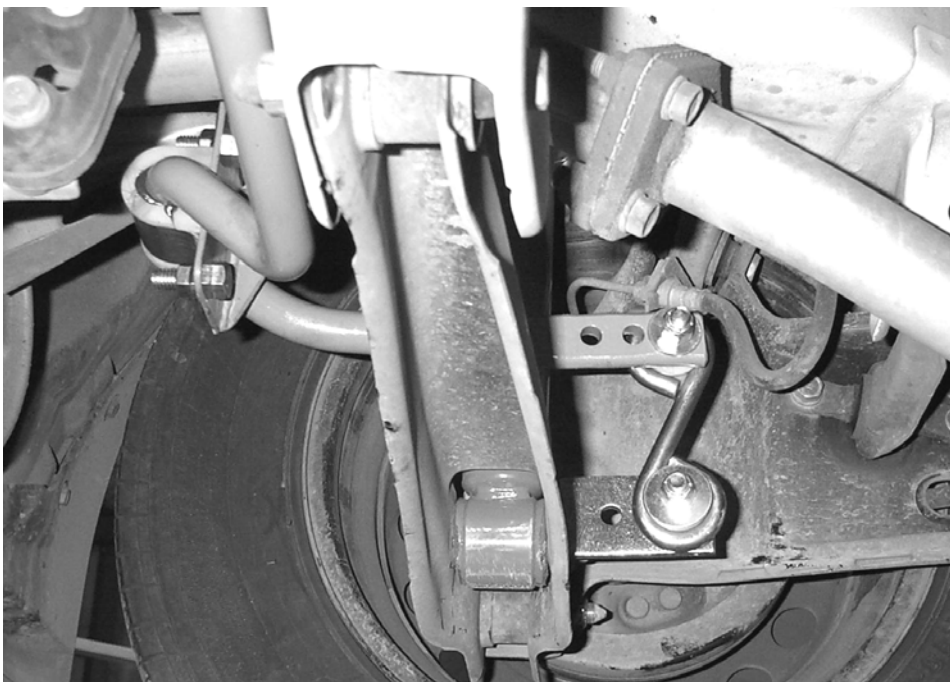

Left Hand side. Note that the swaybar is
behind the bracket assembly

General Fitting Guide - For WHITELINE swaybars.

Page 1 of 2

Universal swaybar fitting guide for replacement and full kit swaybars, to be used whenever specific fitting instructions are not supplied or as a supplementary fitting instruction sheet.

Sound motor vehicle mechanical knowledge is expected.

Stage 1. Swaybar fitment.

- For replacement type swaybars, take note of the fitment, alignment and clearances of OEM swaybar, endlink and any other associated components before removing.
- Apply supplied grease to the contact surfaces of new bushings.
- Place the swaybar in position and connect to the chassis. Parts supplied, procedure to follow and configuration type will vary between individual swaybars.
- In some cases, it may be necessary to raise the vehicle and/or remove road wheels and/or suspension, drive-train or exhaust system components. It is critical that vehicle is safely secured on hoist or on chassis stands.

If suspension components need to be removed, it may be beneficial to measure original wheel alignment settings before continuing

- Proper safety procedures must be followed, and care taken. Be extra careful when working with hot components.
- Always use new hardware if supplied.
- Only tighten fittings with the vehicle at ride height.

Stage 2. Swaybar link assembly fitment and adjustment.

- Swaybar endlink assembly, fitment and tensioning is best done with the vehicle at normal ride height to ensure correct alignment, clearance and operation.
- Fit the swaybar link assembly in place. Parts supplied, procedure to follow and configuration type will vary between individual swaybars.
- For replacement type swaybars supplied without links, re-use factory links and hardware.
- For swaybars supplied with new links and hardware, refer to Figures 1 to 4 for bushing type endlink and their correct assembly. Refer page 2 for Ball-style.
- Whiteline Blade adjustable swaybars vary between 2, 3 and 4 holes per side, depending on application. Refer to Fig. 5 to work out the desired setting on how to connect the endlink. If multi-hole endlink brackets are supplied, choose the hole that maintains the endlink close to vertical.

Caution: WHITELINE recommends starting with softer setting rather than harder.

- Always use new hardware if supplied.
- Tighten all fittings with the vehicle at ride height.

Caution: Do not over tighten swaybar pin type link bushes, refer Fig 1. Nuts should be tightened until washer meets the bush & stops rotating. Then tighten a further $\frac{2}{3}$ of a turn. Over tightening compresses and pre-loads the polyurethane bush which reduces articulation and may cause premature failure.

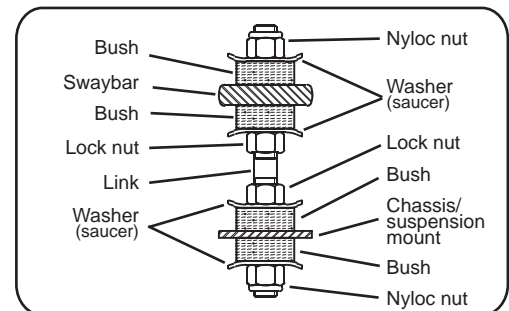

Fig.1. Whiteline double pin type link.

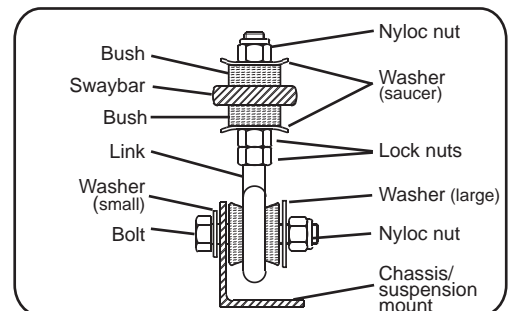

Fig.2. Whiteline pin/eye type link.

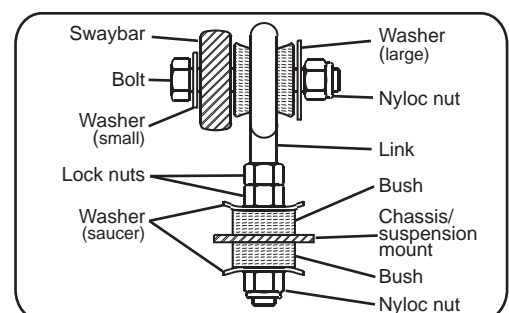

Fig.3 Whiteline eye/pin type link.

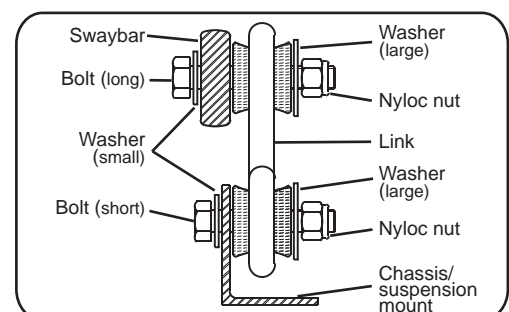

Fig.4 Whiteline double eye type link.

Warning: Please drive carefully while you accustom yourself to the changed vehicle behaviour.

General Fitting Guide - For WHITELINE swaybars.

Continued - Page 2 of 2

Universal swaybar fitting guide for replacement and full kit swaybars, to be used whenever specific fitting instructions are not supplied or as a supplementary fitting instruction sheet.



Stage 3. Post installation check and maintenance.

- Depending on the application and the removal of suspension components during installation in stages 1 and 2, wheel alignment settings may have been altered. Check wheel alignment settings, and adjust as required.
- Re-tension all fittings after a settling-in period, but not later than 100kms (60miles) after installation.
- For noise and friction free operation, carry out periodic inspections and maintain proper bushing lubrication.

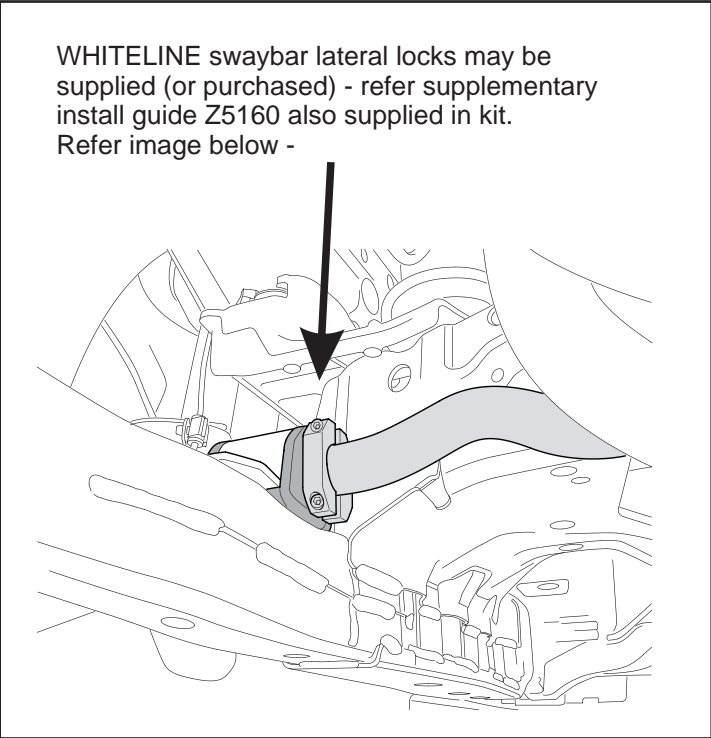
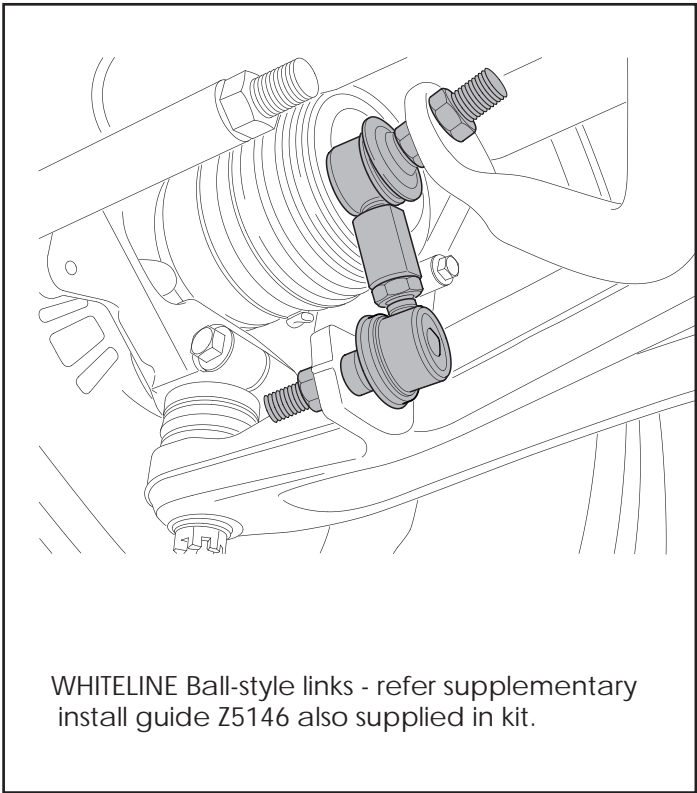

Fig.5 WHITELINE 3 hole Blade swaybar



WHITELINE Blade adjustable swaybar - rate adjustment guide

Warning: Please drive carefully while you accustom yourself to the changed vehicle behaviour.

GREASE FREE TECHNOLOGY



Introducing Grease Free Technology Bushings

Bushings supplied in this kit feature not only the latest synthetic elastomer bushing material technology but a high performing PTFE inner lining boasting an extraordinary low coefficient of friction. This inner lining eliminates the need to lubricate the bushing on installation and therefore makes these bushing 'grease free'!

Superior friction management

- reduces heat build up known to deform or degrade bushing over time
- dramatically reduces high frequency noises (squeaking)
- eliminates the need for maintenance/ greasing

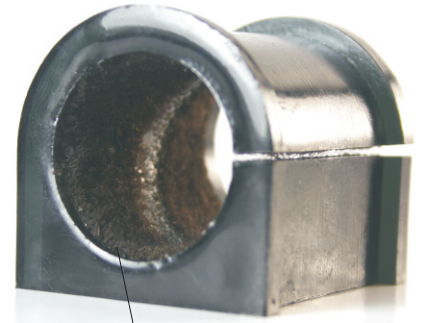

PTFE LINING

Installation tip

Ensure a clean mating surface when installing these bushings for optimum performance!

Frequently Asked Questions

What happens if I do apply grease to the lining?

Don't stress, simply wipe away as much of the lubricant from the surface as possible and install. Adding grease does not further improve the bushings function/ performance nor does traces of lubricant impede the function/ performance.

Do I need to grease other areas of the bushing?

Simply, no! Unless the kit is supplied with a grease packet and lubrication instructions, no other area of the bushing requires lubrication.

Do these bushings require maintenance?

Significant improvements in grease retention within bushing design has dramatically improved over recent years, however this new grease free technology does away with all lubricants and subsequent or periodical maintenance.

Is this technology available across the entire range?

For the most up to date offering of grease free technology bushings visit the website!

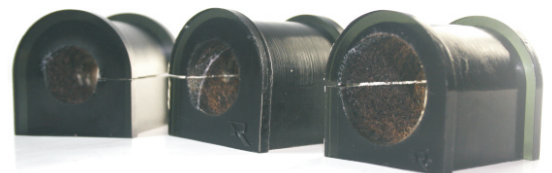
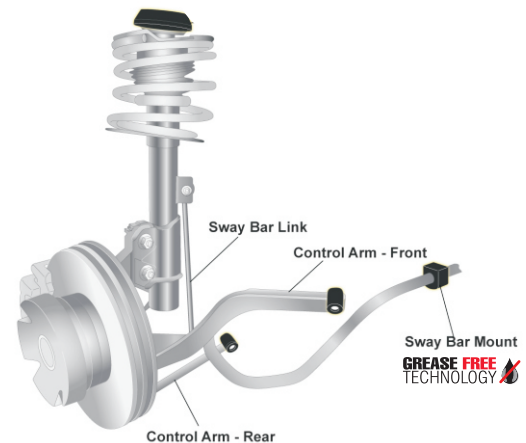

FRICION FREE | SILENT OPERATION | MAINTENANCE FREE