

# General Fitting Guide - For WHITELINE swaybars.

Page 1 of 2

Universal swaybar fitting guide for replacement and full kit swaybars, to be used whenever specific fitting instructions are not supplied or as a supplementary fitting instruction sheet.

Sound motor vehicle mechanical knowledge is expected.

## Stage 1. Swaybar fitment.

- For replacement type swaybars, take note of the fitment, alignment and clearances of OEM swaybar, endlink and any other associated components before removing.
- Apply supplied grease to the contact surfaces of new bushings.
- Place the swaybar in position and connect to the chassis. Parts supplied, procedure to follow and configuration type will vary between individual swaybars.
- In some cases, it may be necessary to raise the vehicle and/or remove road wheels and/or suspension, drive-train or exhaust system components. It is critical that vehicle is safely secured on hoist or on chassis stands.

*If suspension components need to be removed, it may be beneficial to measure original wheel alignment settings before continuing*

- Proper safety procedures must be followed, and care taken. Be extra careful when working with hot components.
- Always use new hardware if supplied.
- Only tighten fittings with the vehicle at ride height.

## Stage 2. Swaybar link assembly fitment and adjustment.

- Swaybar endlink assembly, fitment and tensioning is best done with the vehicle at normal ride height to ensure correct alignment, clearance and operation.
- Fit the swaybar link assembly in place. Parts supplied, procedure to follow and configuration type will vary between individual swaybars.
- For replacement type swaybars supplied without links, re-use factory links and hardware.
- For swaybars supplied with new links and hardware, refer to Figures 1 to 4 for bushing type endlink and their correct assembly. Refer page 2 for Ball-style.
- Whiteline Blade adjustable swaybars vary between 2, 3 and 4 holes per side, depending on application. Refer to Fig. 5 to work out the desired setting on how to connect the endlink. If multi-hole endlink brackets are supplied, choose the hole that maintains the endlink close to vertical.

**Caution:** WHITELINE recommends starting with softer setting rather than harder.

- Always use new hardware if supplied.
- Tighten all fittings with the vehicle at ride height.

**Caution:** Do not over tighten swaybar pin type link bushes, refer Fig 1. Nuts should be tightened until washer meets the bush & stops rotating. Then tighten a further  $\frac{2}{3}$  of a turn. Over tightening compresses and pre-loads the polyurethane bush which reduces articulation and may cause premature failure.

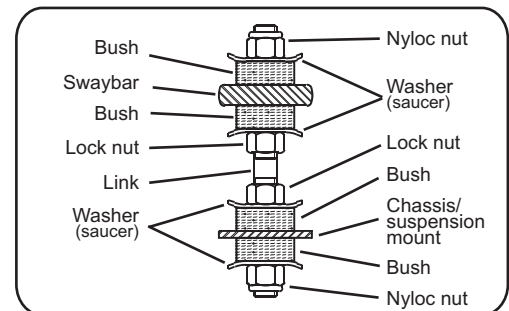

Fig.1. Whiteline double pin type link.

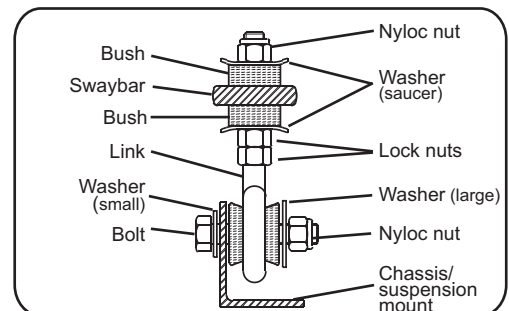

Fig.2. Whiteline pin/eye type link.

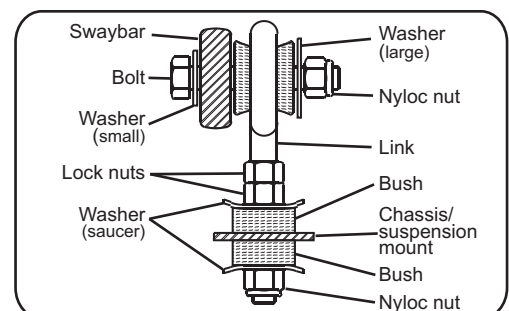

Fig.3 Whiteline eye/pin type link.

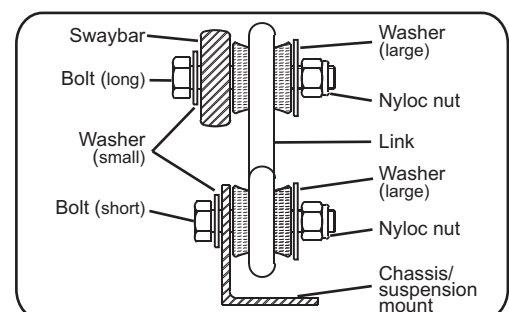

Fig.4 Whiteline double eye type link.

**Warning:** Please drive carefully while you accustom yourself to the changed vehicle behaviour.

# General Fitting Guide - For WHITELINE swaybars.

Continued - Page 2 or 2

Universal swaybar fitting guide for replacement and full kit swaybars, to be used whenever specific fitting instructions are not supplied or as a supplementary fitting instruction sheet.



**Stage 3. Post installation check and maintenance.**

- Depending on the application and the removal of suspension components during installation in stages 1 and 2, wheel alignment settings may have been altered. Check wheel alignment settings, and adjust as required.
- Re-tension all fittings after a settling-in period, but not later than 100kms (60miles) after installation.
- For noise and friction free operation, carry out periodic inspections and maintain proper bushing lubrication.

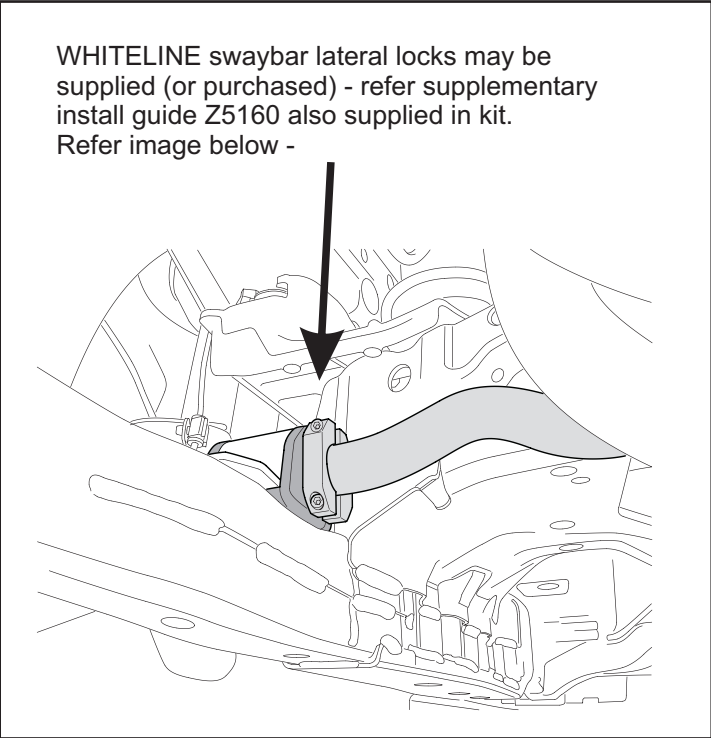
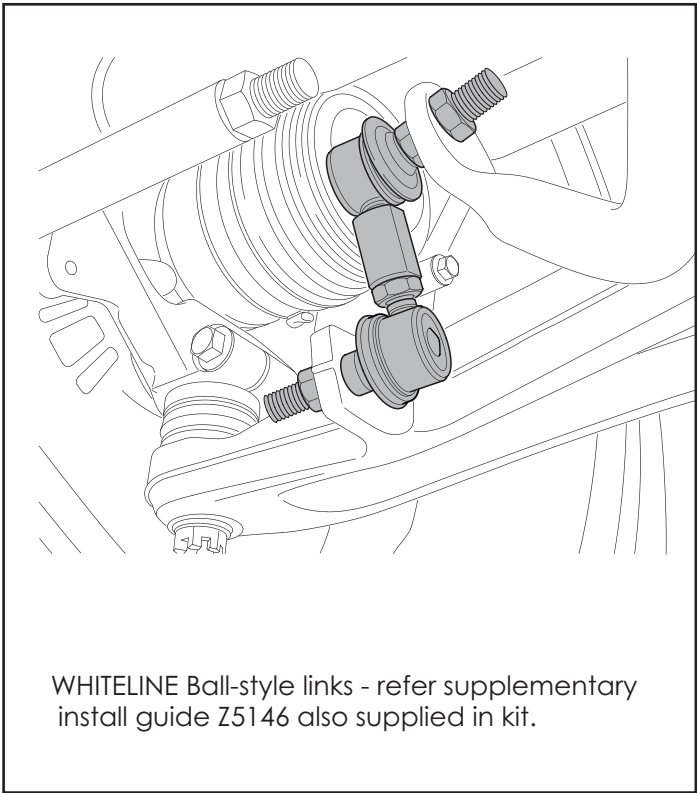

Fig.5 WHITELINE 3 hole Blade swaybar



WHITELINE Blade adjustable swaybar - rate adjustment guide

**Warning:** Please drive carefully while you accustom yourself to the changed vehicle behaviour.

# General instructions - Swaybar Bushings, Drop Links

**N.B:** This instruction sheet should be used in conjunction with the workshop manual

If required, vehicle should be jacked up evenly and safely supported with stands,

Ensure all components are free from rust, scale and dirt. Compare new supplied components to old parts for correct application.

Be careful when working near hot components, such as exhaust systems.

Swaybars vertical links do not require greasing. Swaybar mounting points (D bushings) do require greasing - grease internal diameter of bushing only.

Drop links, with a pivoting bushing do require greasing - bushing internal diameter and side face must be greased with the supplied grease only.

Do not over tighten swaybar pin type link bushings

It is recommended, if possible all components be tightened when vehicle is at ride-height.

Depending on application and suspension component removal, it may be necessary to carry out a Wheel Alignment post install.

We suggest re-checking all hardware after initial 100kms travelled.

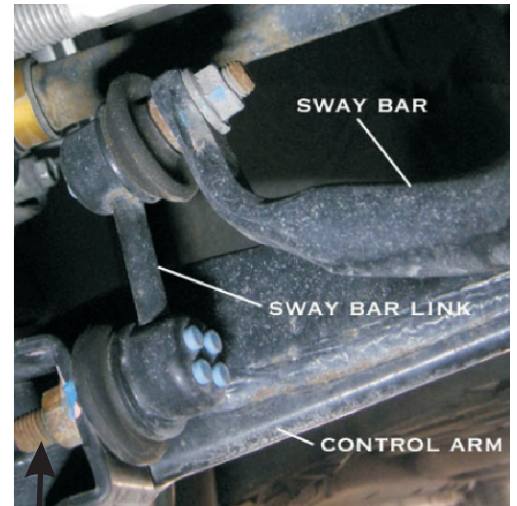

**Re-check Ball Joint nuts after 100kms travelled**

**3 point adjustable swaybar shown below**

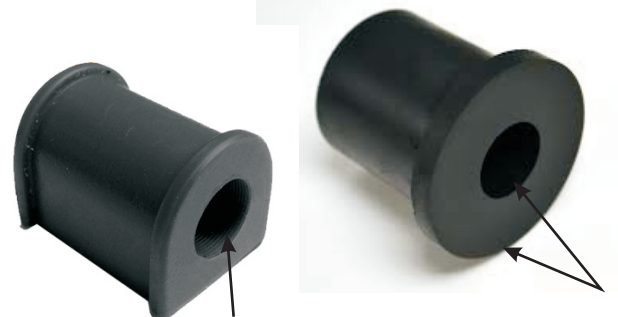
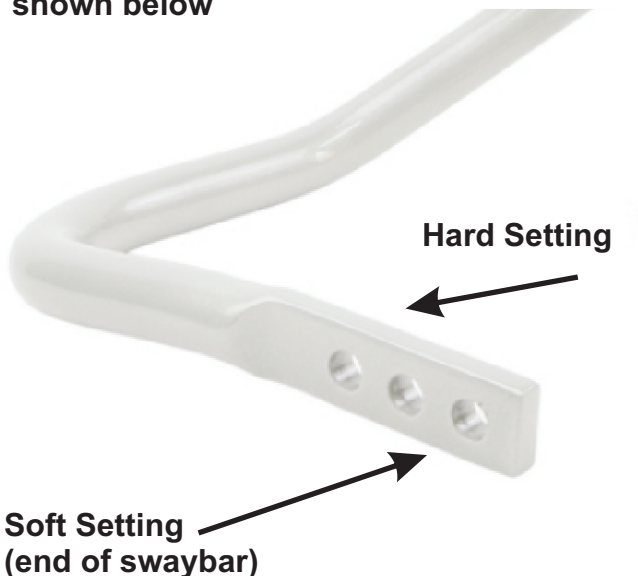

Grease bushing face and ID with supplied grease only

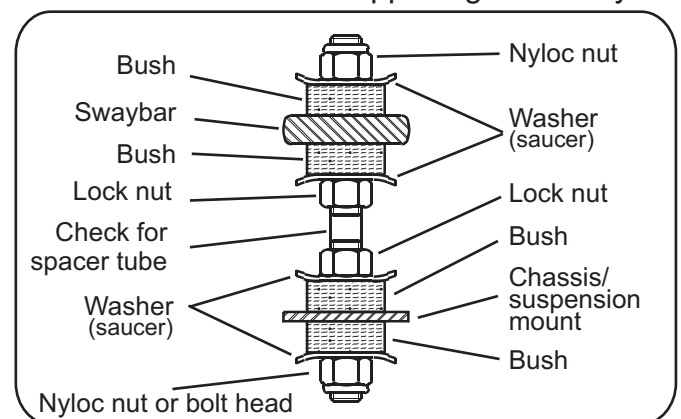

**N.B:** It is recommended that a licenced workshop or tradesperson carry out the above procedure and that workshop manual and relevant safety procedures are followed in addition to the above.