

Front Control Arm Rear Bushing

Application: VW/Audi Mk5 and 6 Platform and Polo MK4

1. Raise the vehicle evenly and safely support.
2. Remove wheels and disconnect the front ball joints.
3. Loosen and remove the front bushing bolt. Note: You may have to slightly lift the engine to clear the A/C compressor.
4. Loosen the vertical mounted rear bolts and remove arm from the vehicle. Note: For Polo models, you will have to cut the rear bushing out of the aluminium sub-frame.
5. Using suitable tooling, remove the arm bushing from the arm. Clean the hex spigot - remove any rubber deposits.
6. Using suitable tooling, press out the OE rubber bushing from the aluminium housing.
7. Push on supplied bushing 60316A over the hex spigot.
8. Push the supplied bushing 60316B into the OE housing with flange facing front of vehicle.
9. Grease the ID of the 60316B bushing with the supplied grease and pop the OE housing over the 60316A bushing.
10. Refit the arm to the vehicle. NOTE: You may have to release the air from the rear of the bushing to guarantee the housing sits correctly for the mounting bolts - refer Fig.1.
11. Bolt the arm back on the vehicle - you may have to loosen the aluminium sub-frame to assist install. Tighten all bolts to OE spec at ride height.
12. Carry out a wheel alignment. re-check all bolts after initial 100kms.

KIT PARTS

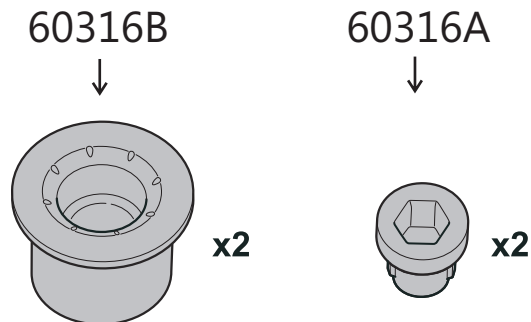

FIG.1

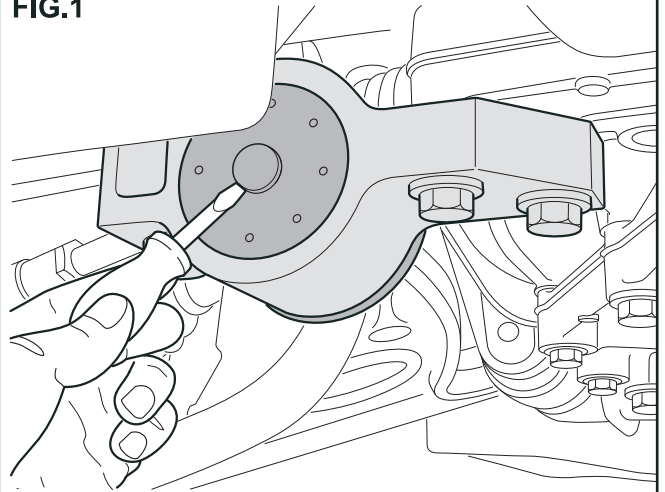

FIG.2

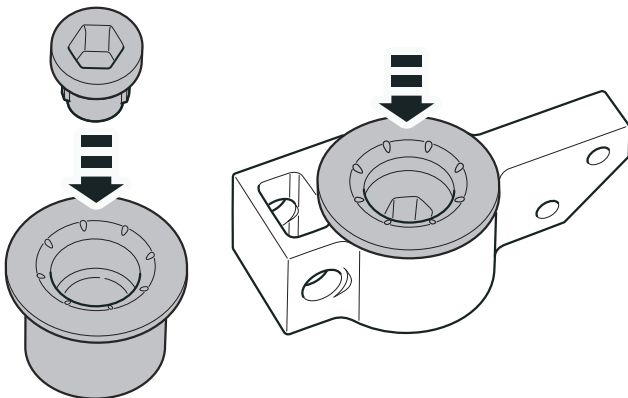
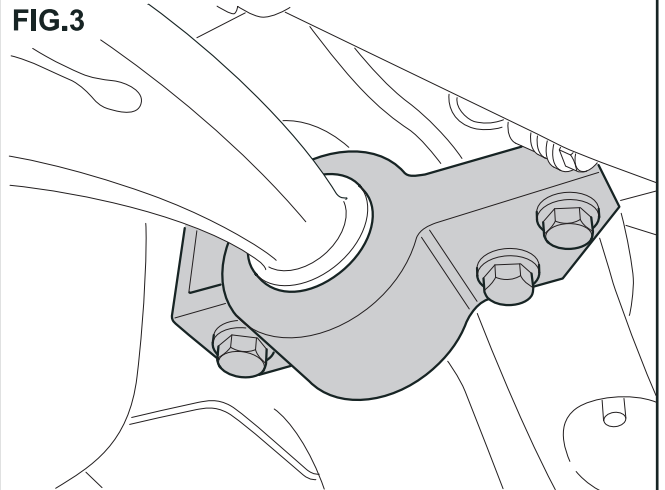

FIG.3



N.B: This installation guide should be used in conjunction with a workshop manual.