

Instructions

Rear Control Arm - Upper Inner

N.B: This instruction sheet should be used in conjunction with the workshop manual and proper safety procedures followed.

Application - VW Golf - Mk7
- VW ALLTRACK

(Refer current catalogue listing)

Contents - 2x steel shell bushings
2x steel tubes
Grease

1. Raise vehicle evenly and safely support.
2. Proceed to remove rear wheels.
3. Un-bolt upper control arm from both inner and outer points.
4. Using a Press, press out the original bushing including outer steel shell.
5. Press in new unit, confirm bushing is central in arm.
6. Grease bushing ID and face with supplied grease only. Push in supplied steel tube.
7. Bolt up arm to vehicle.
8. Tighten bolts at ride height.
9. Carry out a wheel alignment.

MK 7 Rear Suspension

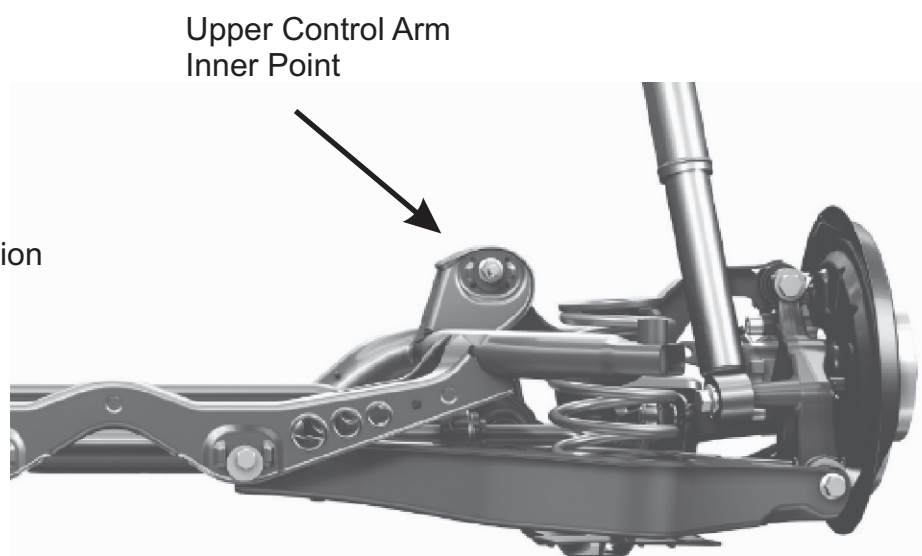

N.B: It is recommended that a licenced workshop or tradesperson carry out the above procedure and that workshop manual and relevant safety procedures are followed in addition to the above.