

FITTING INSTRUCTIONS

Suits: Commodore VR-VE

N.B: These instructions should be used in conjunction with workshop manual.

1. Raise the vehicle and place on chassis stands.
2. Remove the sway bar link, brake and any sensor wire mounts.
3. Remove the strut assembly as a unit.

Note: We recommend that a qualified trades person perform the disassembly and reassembly of the strut unit with a trade recognised coil spring compression tool.

4. With suitable spring compression tool fitted, disassemble and remove the old strut top bush and LOWER cup washer and discard.

Note: Do not discard the original UPPER cup washers as they will need to be re-used in the same position when reassembling, and if bump stop is not refitted and in good condition the warranty may be voided.

5. With bump stop in position fit **supplied** cup washer, replacement 4018A bush (with bearing in place, yellow side down), **original** upper cup washer in the correct position as per diagram below.

Note: The strut leg to steering knuckle bolts must be renewed as they are ONE USE ONLY stretch bolts.

VR/VZ O.E. Bolt: 11090821 **Nut:** 92138205 **Washer:** 92138049

VE O.E. Bolt: 92138863 **Nut:** 92138862 **Washer:** 92138864

6. Re-tension all associated and removed bolts to specification.

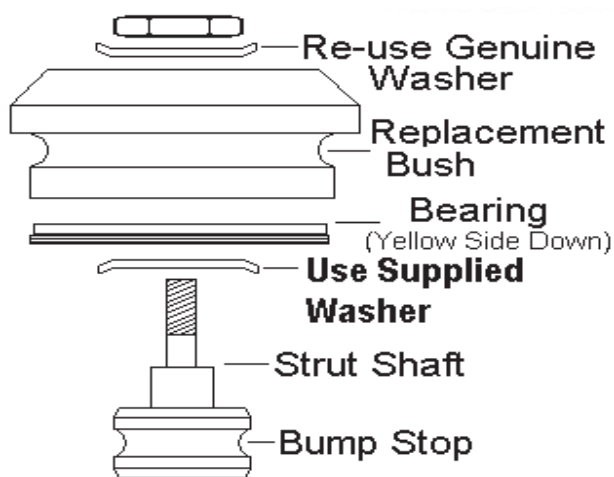

N.B: It is recommended that a licenced workshop or trades person carry out the above procedure and that workshop manual and relevant safety procedures are followed in addition to the above.

Installation Guide

STRUT TOP- HAT ORIENTATION

Suits : HOLDEN COMMODORE VR-VE SERIES

(Always refer to the current catalogue for complete application listings).

N.B. This install guide should be used in conjunction with the workshop manual.

PLEASE NOTE DAMPER-COIL OFFSET

Prior to disassemble please take note of alignment OE markings on both the lower spring seat and upper strut hat

(THESE MARKINGS WILL VARY DEPENDING ON THE YEAR MODEL)

FRONT STRUT/SHOCK ASSY

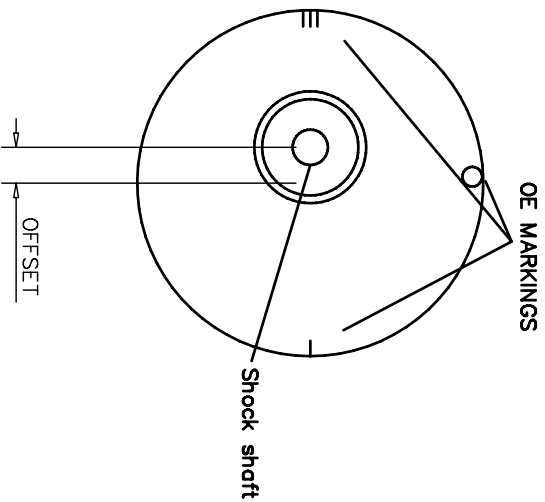

OE UPPER STRUT HAT

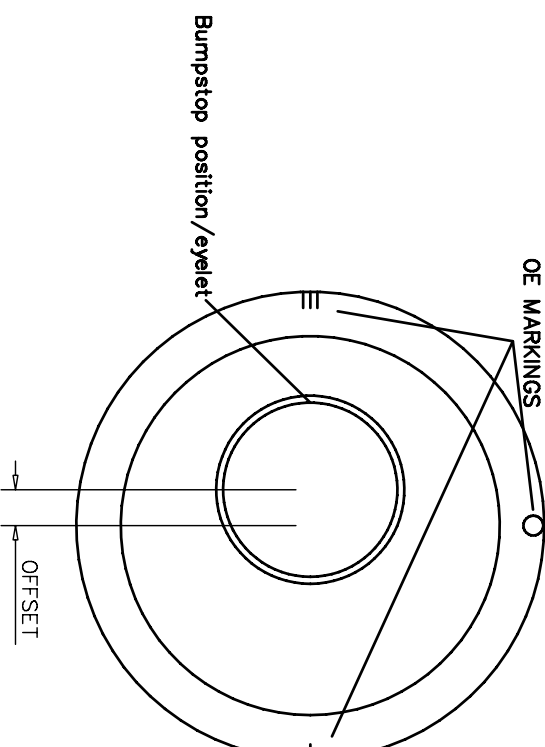

TOP VIEW OF DISASSEMBLED STRUT

N.B. It is recommended that a licenced workshop or trades person carry out the above procedure and that workshop manual and relevant safety procedures are followed in addition to the above.