

Installation Guide

Front Lower Control Arm

Z 5054B

Suits: Toyota Pardo 120 Series & 05-On Toyota Hilux 4WD

(Always refer to the current catalogue for complete application listings)

N.B: This installation guide should be used in conjunction with the workshop manual.

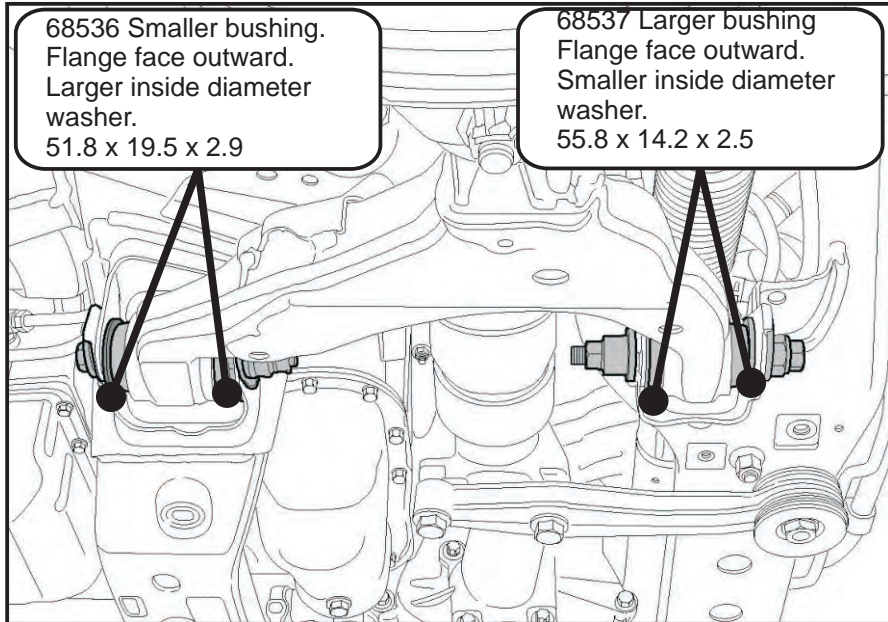

- Raise and support the vehicle on chassis stands.
- Remove the road wheels from vehicle.
- Remove the two lower ball joints.
- Remove the shock absorber lower mounting bolts from the lower control arm.
- Loosen the two inner lower control arm bolts from the vehicle.
- While supporting the wheel hub assembly remove the two lower control arm bolts and control arm from the vehicle.
- Remove OEM lower control arm bushings from the arm.
- Inspect the arm for damage and burrs, repair or replace as necessary.
- Install the supplied bushings into the arm with the flange faces installed outward. Bushing fitment may be aided with the assistance of soapy water.
- Apply liberal amounts of grease to all the running surfaces of the bushings.
- Re-install lower control arms to the vehicle and tension all bolts to manufacturers specifications.
- Re-fit road wheels and settle the vehicle on the ground.
- Carry out a wheel alignment as required.

N.B: It is recommended that a licenced workshop or trades person carry out the above procedure and that workshop manual and relevant safety procedures are followed in addition to the above.