

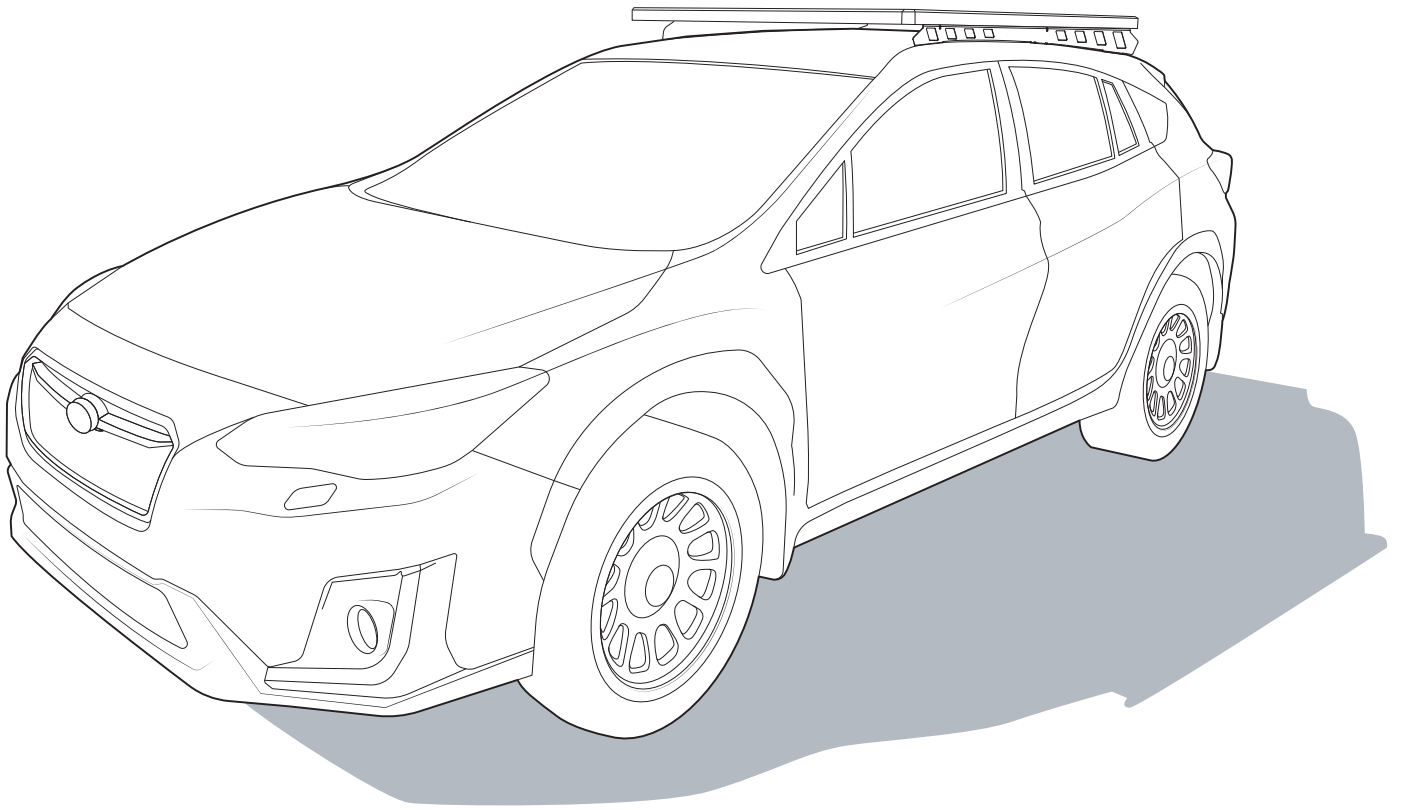







KAYMAR

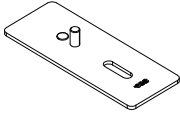
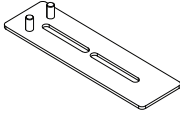
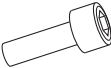
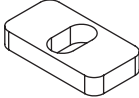

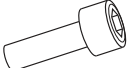
Read this full instruction prior to commencing assembly and fitment of Ridge Mount System.

CONTENT - CHECK ALL PARTS ARE CORRECT BEFORE PROCEEDING

A		Ridge Mount (pair)	1
B		Front Stud Plate	2
C		Rear Stud Plate	2
D		M6x20mm Cap Screw	12
E		5mm Spacer	12
F		M8 Flat Washer	32
G		M8 Nyloc Nut	14
H		M8x25mm Cap Screw	6
I		Butyl Patch	24
J		M6 Washer	12
K		M6 Nut with Washer	12

TOOLS REQUIRED

- 13mm, 14mm, 10mm socket wrench.
- Step ladder.
- Clean cloth.
- Trim tools.

- Phillips head screw driver.

A

Move to the side of the vehicle. Use a step ladder to get access to the vehicle roof. This will be required at a later stage.

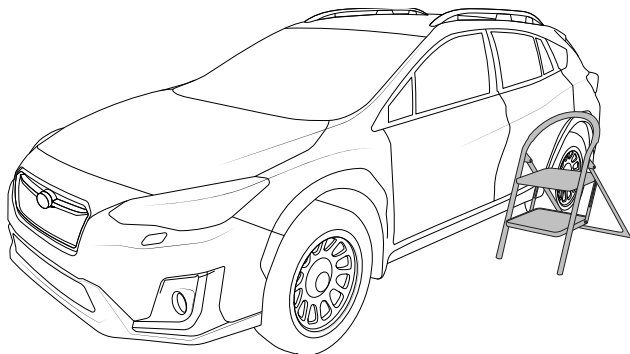

WARNING:

Disconnect battery before removing roof liner. To ensure all power has dissipated from the capacitors pump the brakes a few times and turn the lights on and off.

ROOF LINING REMOVAL instructions

1

Be sure battery is disconnected.

Remove the cover from the sun visor and unscrew the two screws, pull the sun visor down gently until you can reach the connector and unplug.

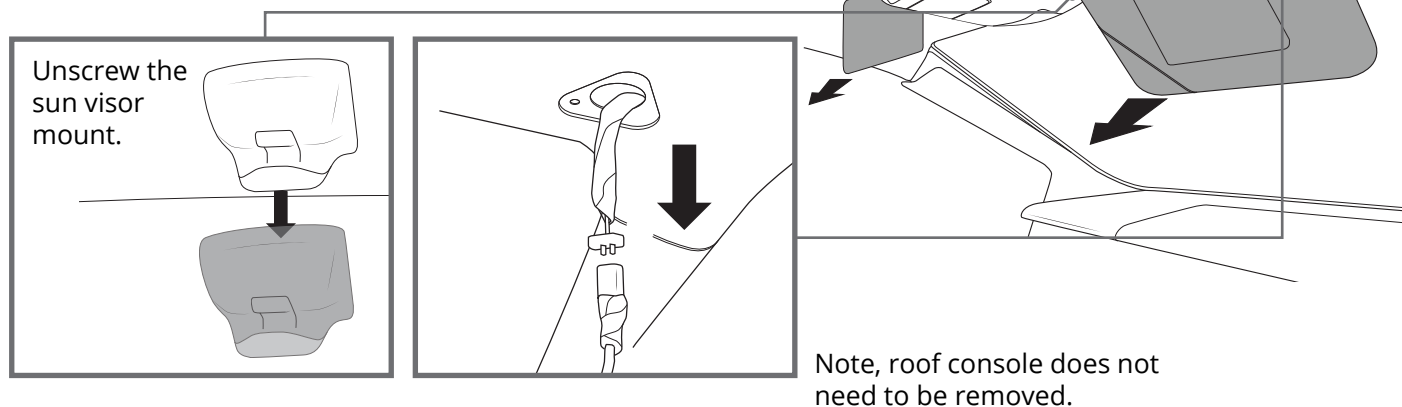

2

Gently unclip the A pillar plastic trim.



3

Remove the grab handles above each of the doors.

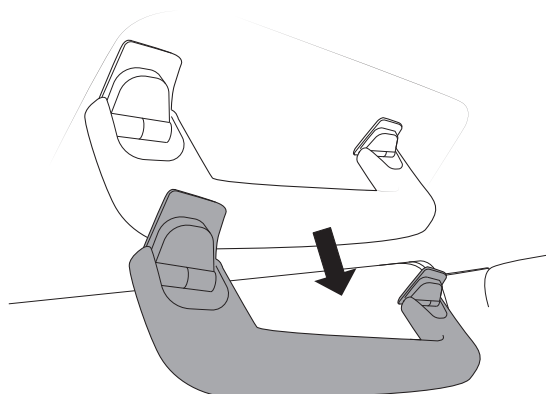
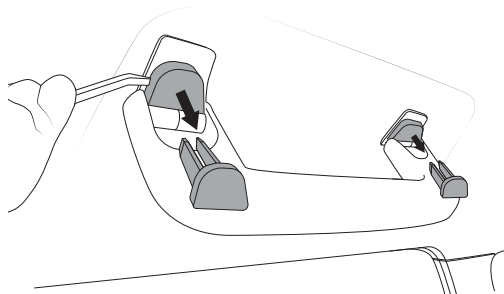

4

Unpeel the rubber door trim so that the top trims are exposed (approx. 50% from the top portion of the vehicle).

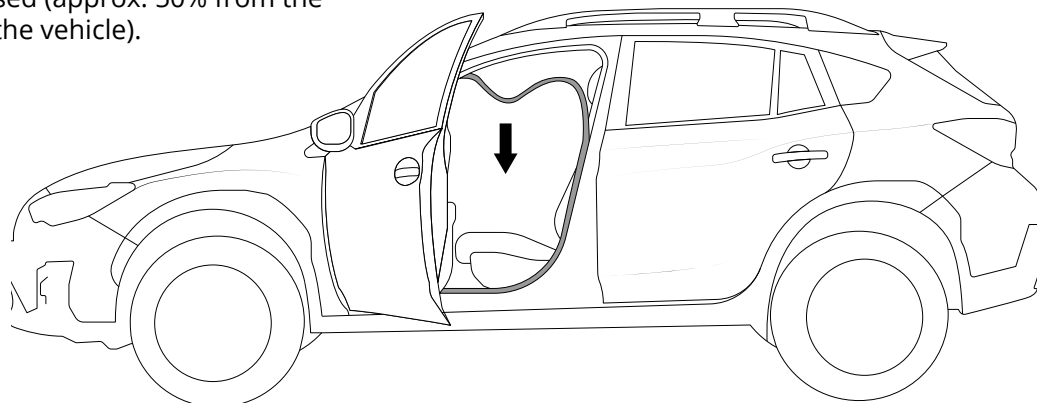

5

Move the seat back and recline for best access (don't do this if the seats are powered). Use thin forked trim tool to undo 2x clips behind the lower b-pillar and gently pull it away from the wall enough to access to upper b-pillar screw and unscrew it with a phillips head screw driver or 10mm socket wrench.

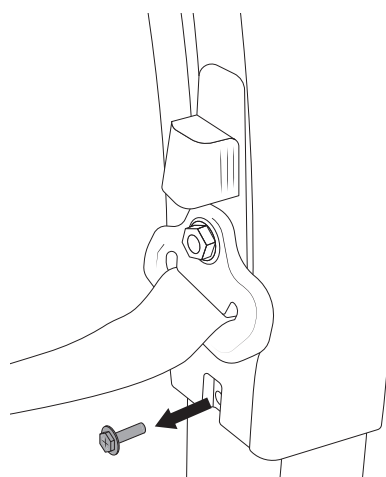
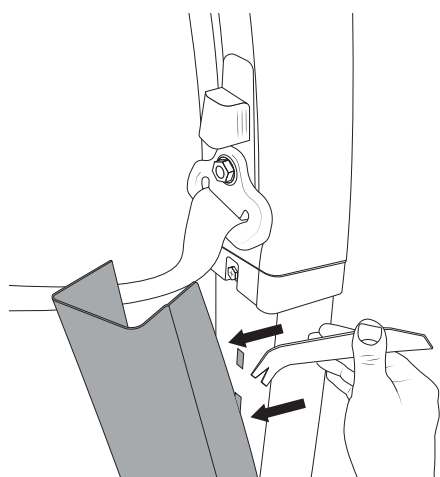

6

Unclip the seat belt cover using the clips at the back, then unscrew the nut using a 14mm socket wrench.

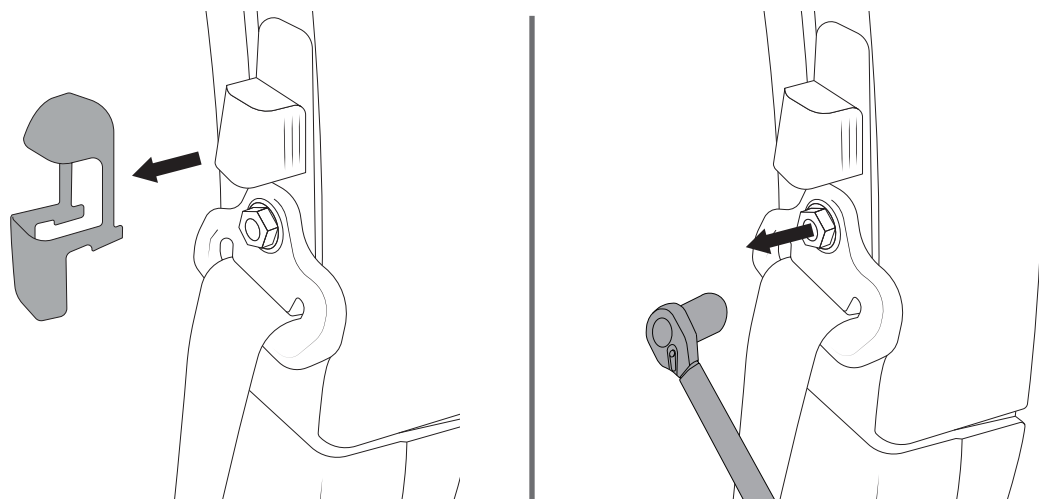

7

Move to the boot of the vehicle.

Unclip the 3x clips from the roofline of the boot using a thin forked trim tool.

On the side panels of the boot unscrew the 2x screws with a phillips head screw driver and unclip the 5x clips (approx. location shown below) using a thin forked trim tool.

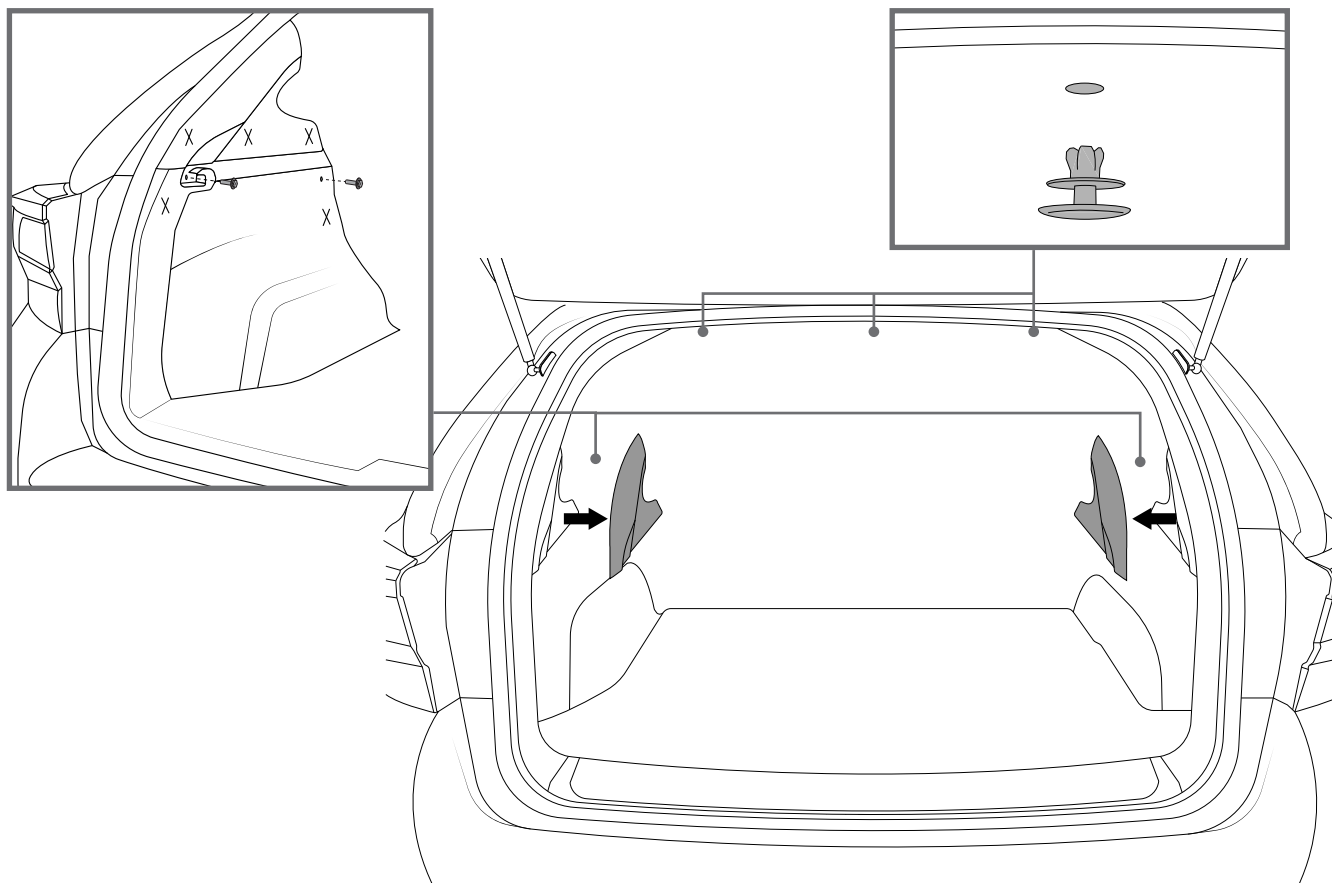

Once all the trims and screws have been removed, begin the gently pull down on the roof lining from the boot of the car.

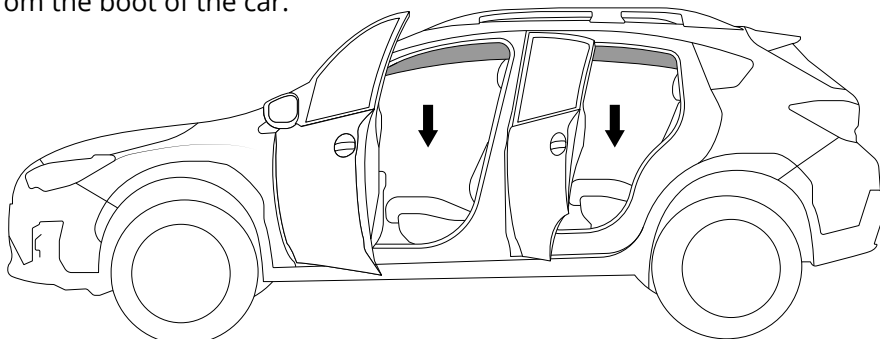

SYSTEM INSTALL

On the inside of the roof, unscrew the factory rails using a 10mm socket wrench.

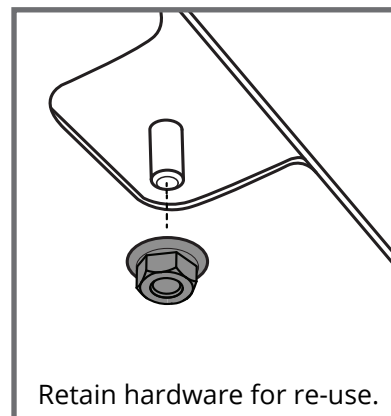
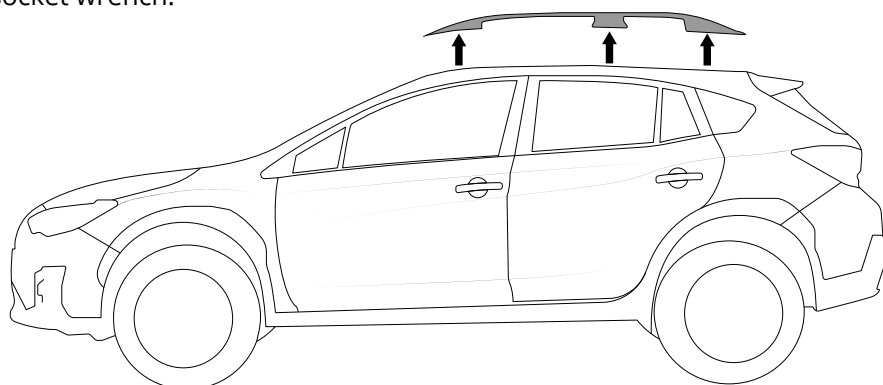

Clean the ditch where the factory rails have been removed.
 (A) Using butyl mastic, apply the sealant to all exposed holes in the roof.
 (B) Apply 2x Patch to each hole. All holes are used for mounting.

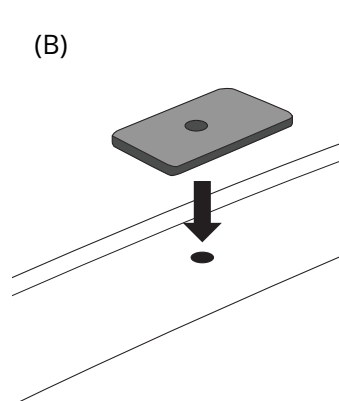
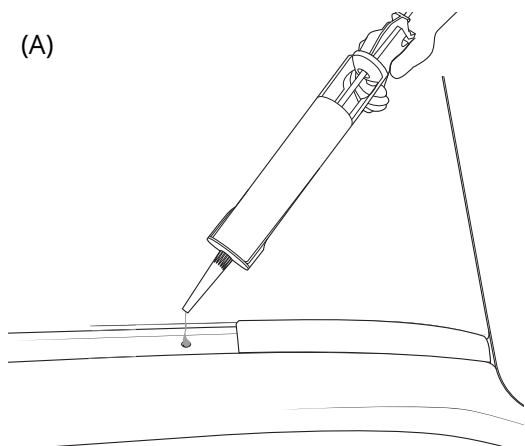

Peel off protective strip to expose adhesive surface.

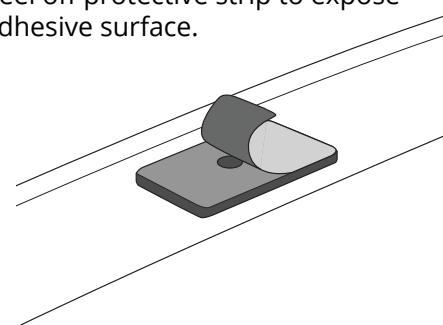

Install the kit provided M6 hardware into each rail.

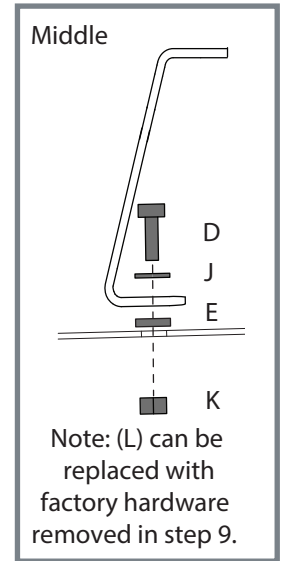
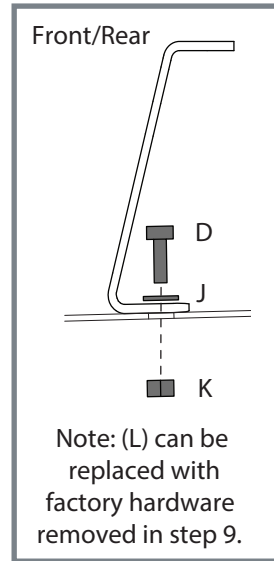
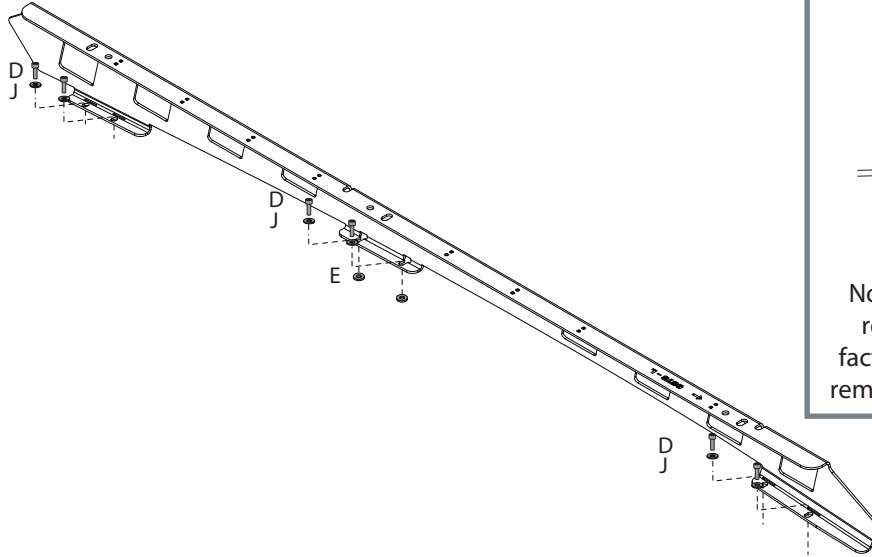

Place the rails onto the roof of the vehicle.

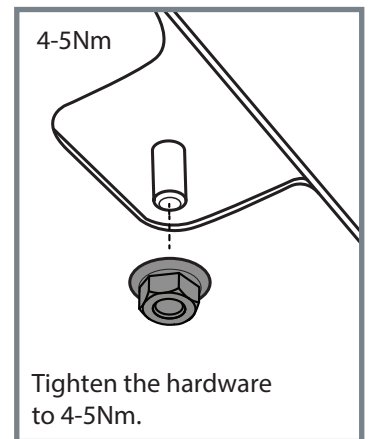
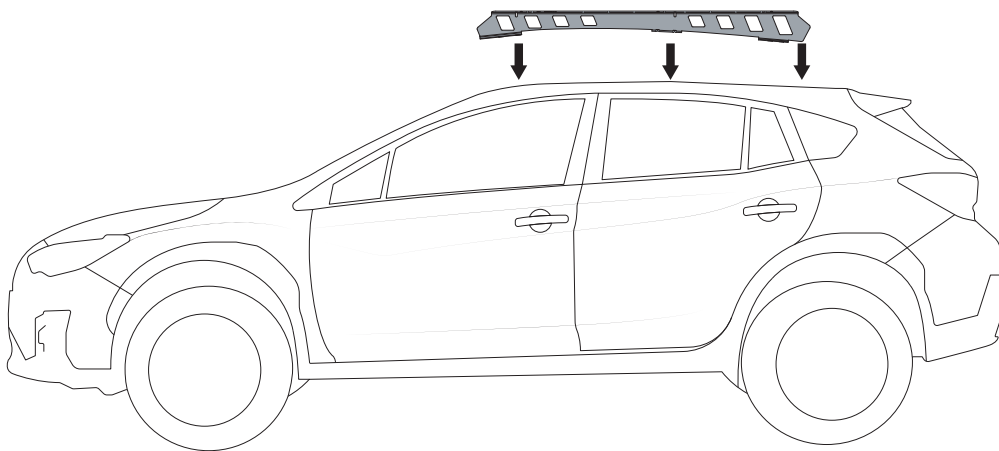

Replace the roof liner, using the liner removal steps in reverse order.

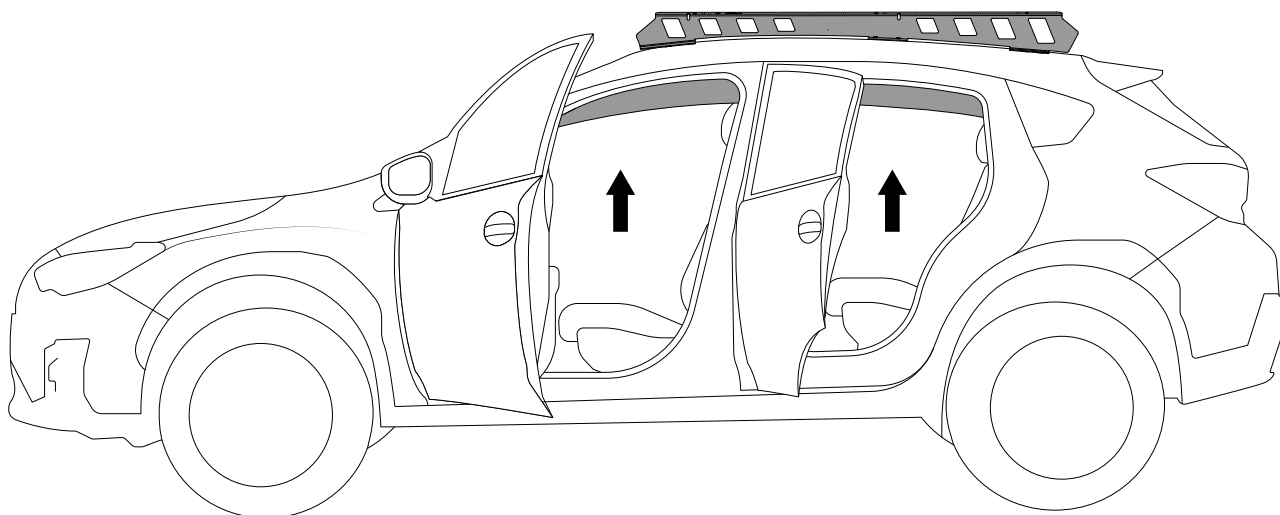

Install the stud plates as shown.
Tighten with a 13mm socket.

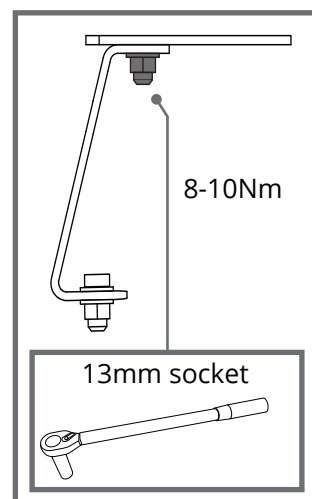
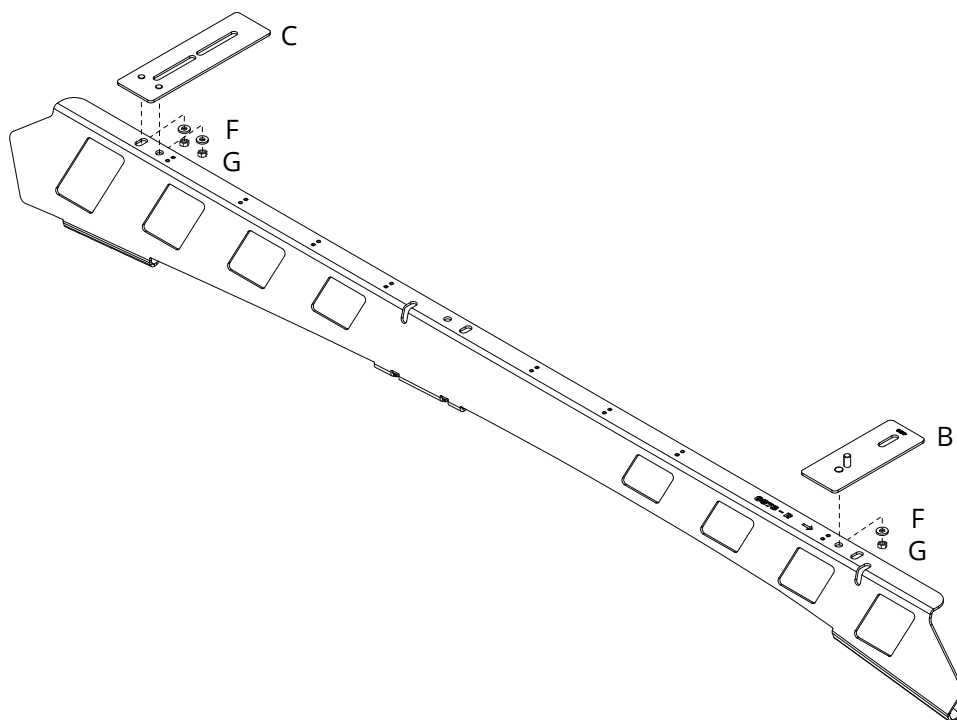

PLATFORM FITMENT

15

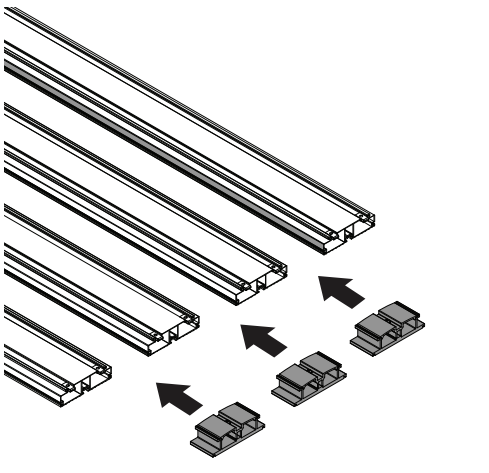

Install the interlocking blocks, as per Fitting Instructions.

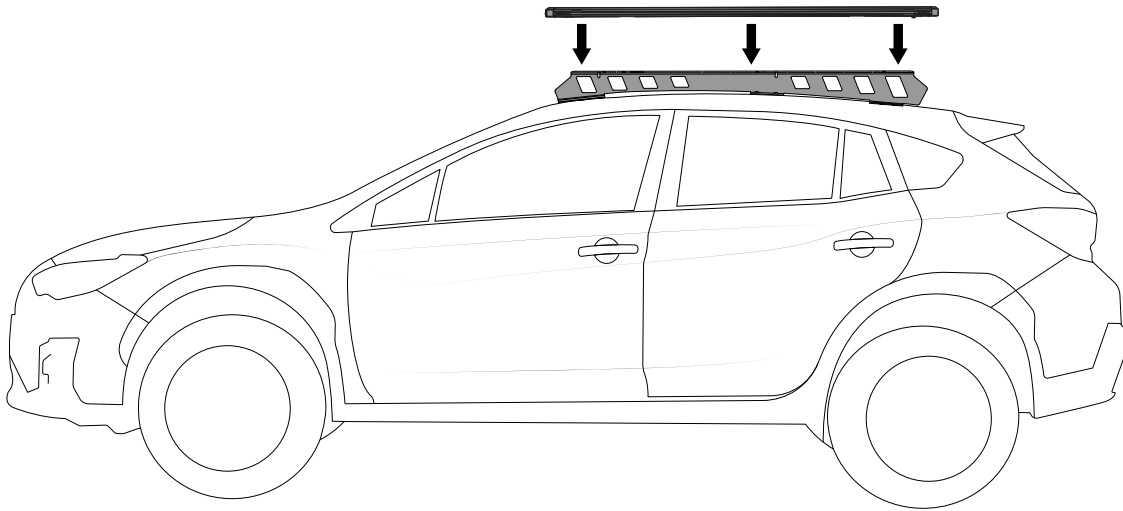
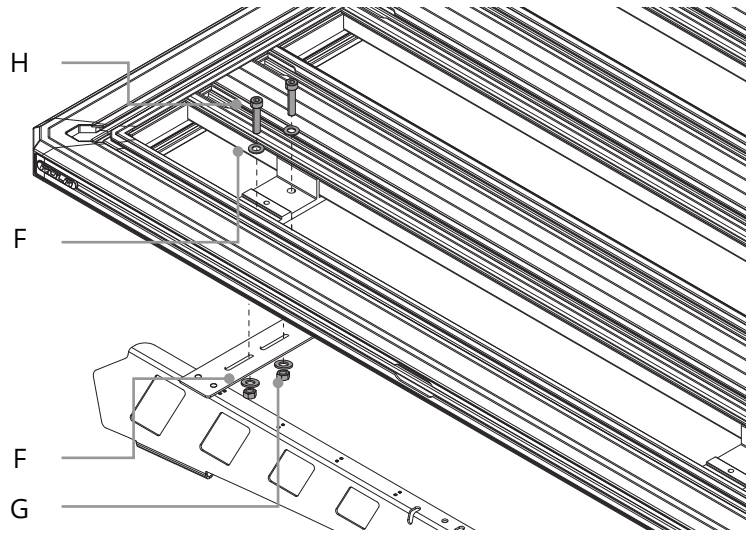

Note:

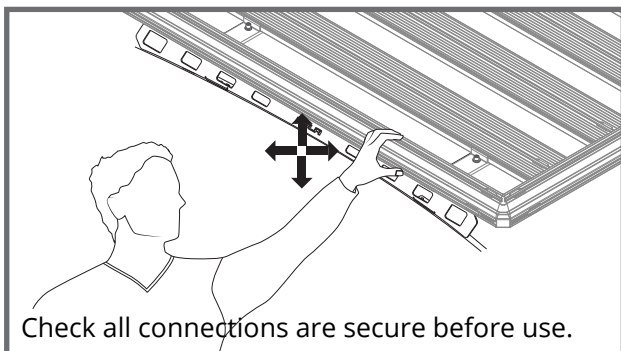

Wiring can be run and secured on the underside of the Ridge Mount rail as shown.

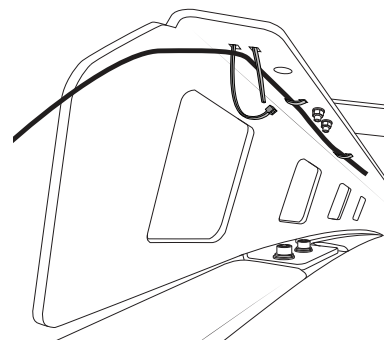

IMPORTANT - READ BEFORE USE

Please ensure the system is fitted in accordance with the fitting instructions.
It is important that you observe all outlined below.

**LOAD RECOMMENDATIONS**

- Routinely and regularly check the proper functioning of the system. Check all fixtures at regular intervals.
- Do not use an automatic carwash with system installed.
- Maximum load capacity of the system is 661lbs/300kg under static conditions.
- Maximum load capacity of the system is 220lbs/100kg under dynamic including off-road conditions.
- Do not exceed vehicle manufacturers recommended load rating if it is lower than the maximum load capacity specified in this document (i.e., 220lbs/100kg).
- Ensure any load carried is evenly distributed.
- Actual load on vehicle Roof (Refer to owner's manual) = Weight of Roof rack system / Ridge Mount + Weight of platform + Weight of cargo.
- Actual load on rack system (Refer to product instructions) = platform weight + cargo.

WARRANTY INFORMATION

For full Warranty details refer to Kaymar website.

Kaymar.com.au

NOTE

All content subject to APG copyright.