

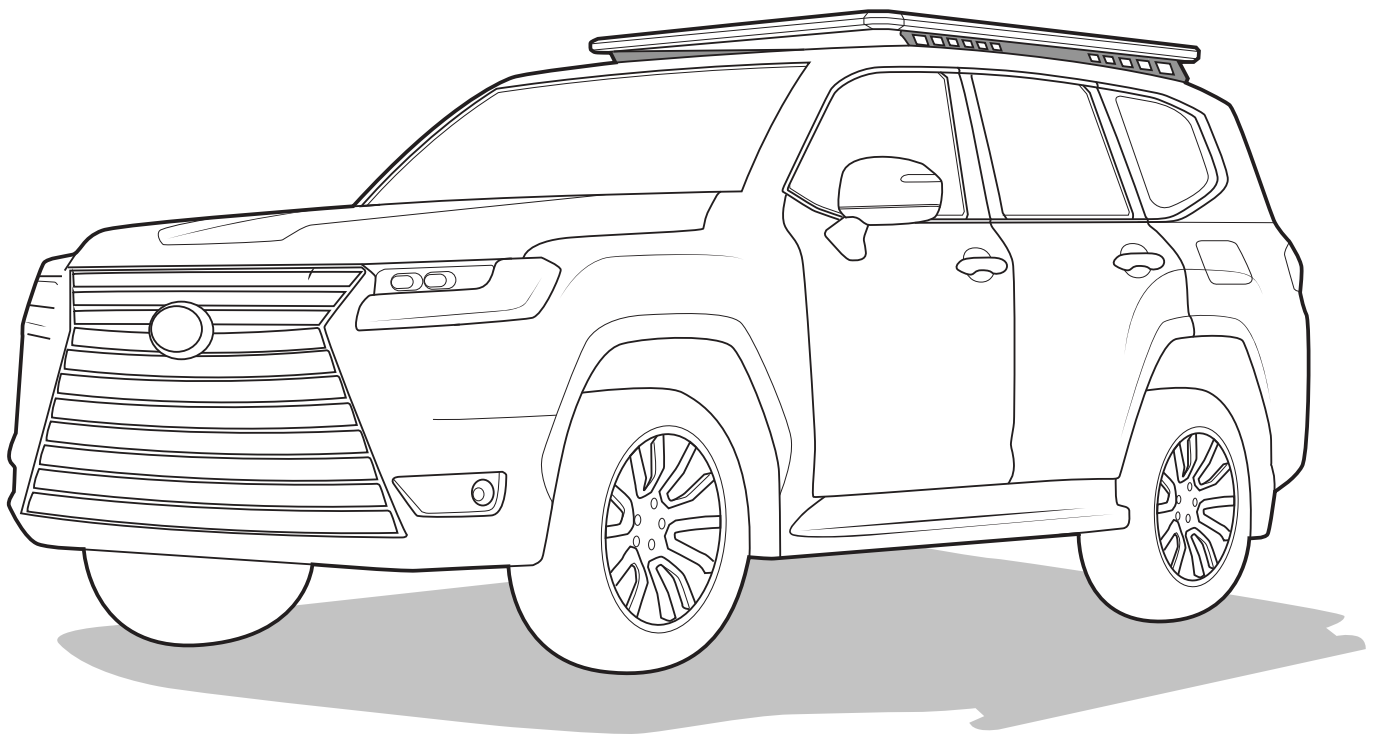







KAYMAR

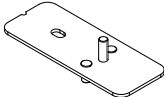
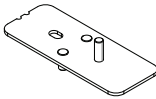
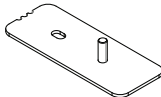

Read this full instruction prior to commencing assembly and fitment of Ridge Mount system.

CONTENT - CHECK ALL PARTS ARE CORRECT BEFORE PROCEEDING

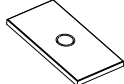
A		Ridge Mount (Pair)	1
B		Stud Plate Front	2
C		Stud Plate Middle	2
D		Stud Plate Rear	2
E		Rubber Washer	16
F		M8 Nyloc Nut	22
G		M8 x 17mm Flat Washer	46
H		M8 x 30mm Cap Screw	24
I		M8 Spring Washer	16
K		Butyl Patches	16

TOOLS REQUIRED

- 6mm allen tool.
- 12mm, 13mm socket wrench.
- Step ladder.
- Butyl mastic sealant.
- Flat blade screwdriver.
- Trim removal tool.

1

Move to the side of the vehicle. Use a step ladder to get access to the top of the vehicle.

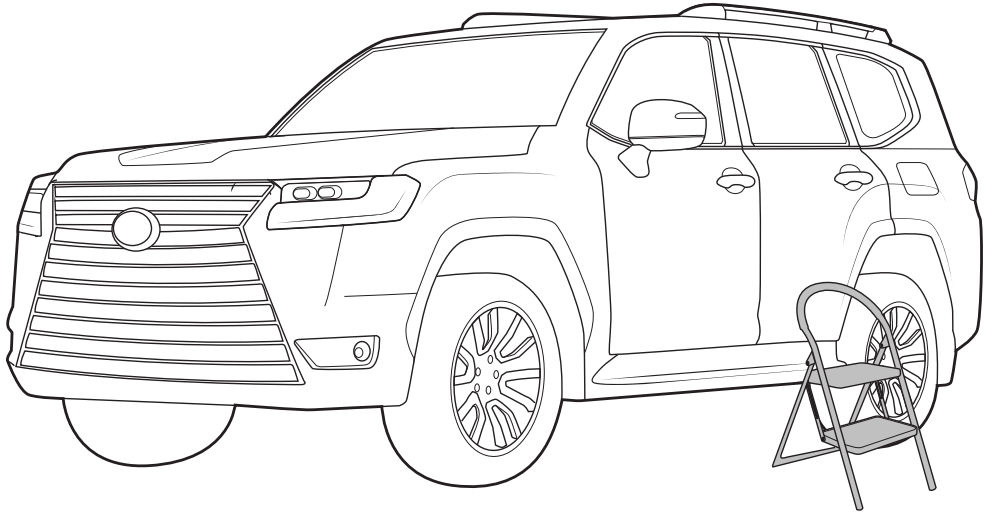

2

Using a trim removal tool, carefully pry off the rail covers at the front, middle and rear.

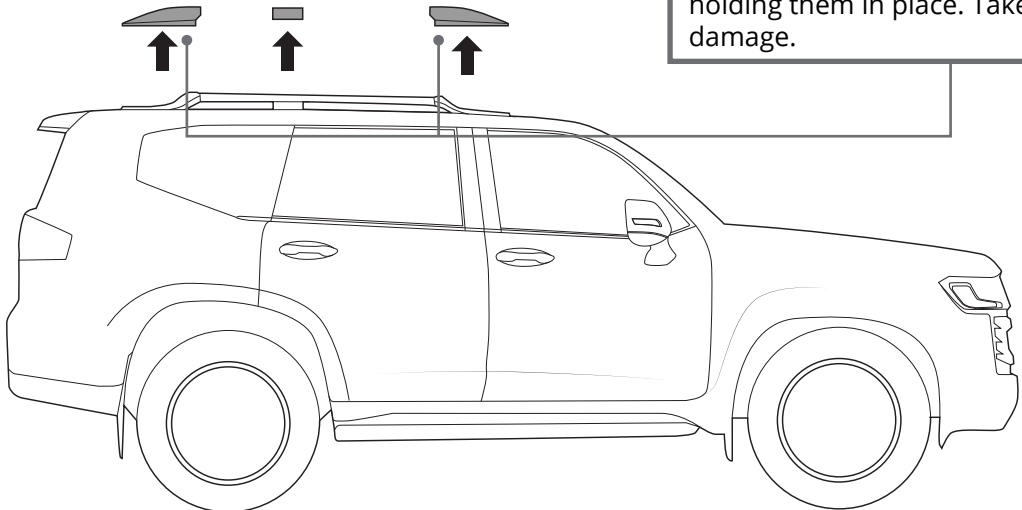
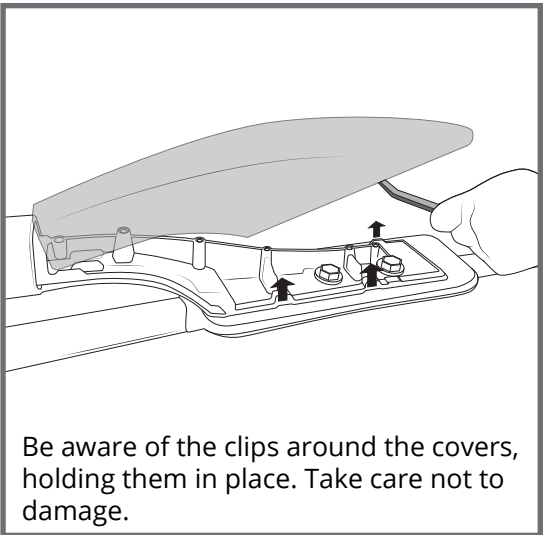
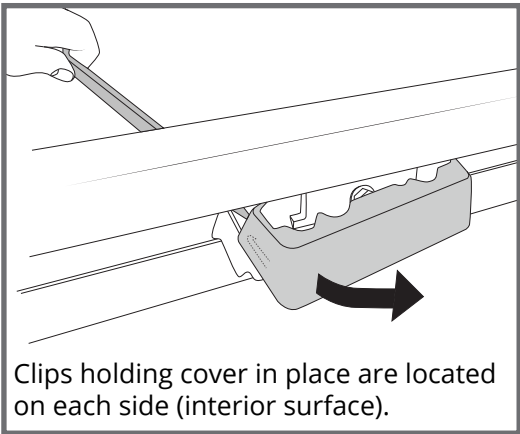

3

Using a 13mm socket wrench, carefully remove the bolts holding the rail in place.

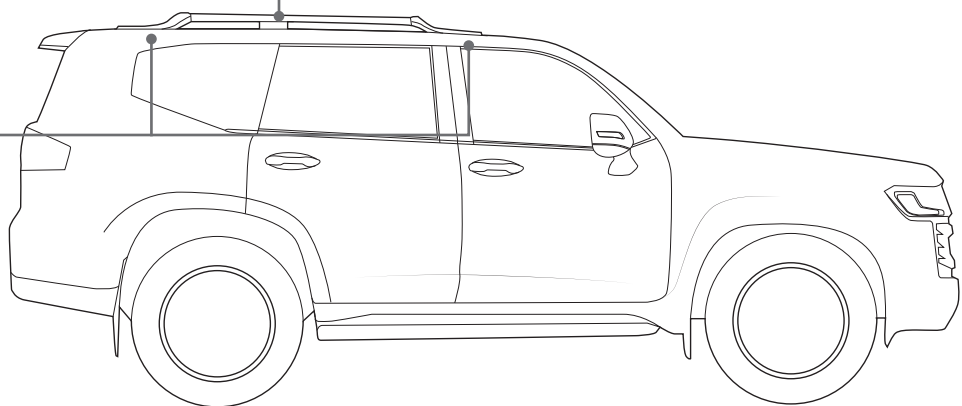
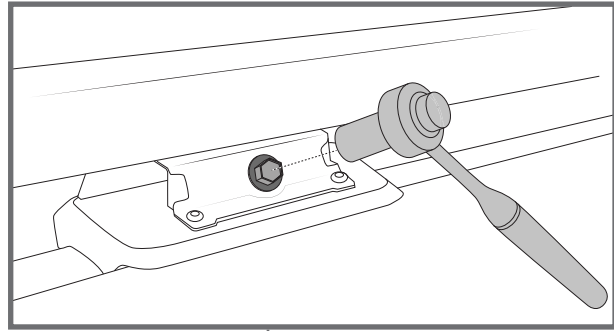
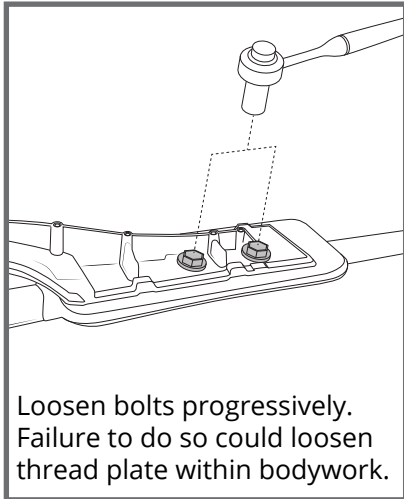

4

Carefully remove the factory rails. Clean the roof of the vehicle thoroughly.

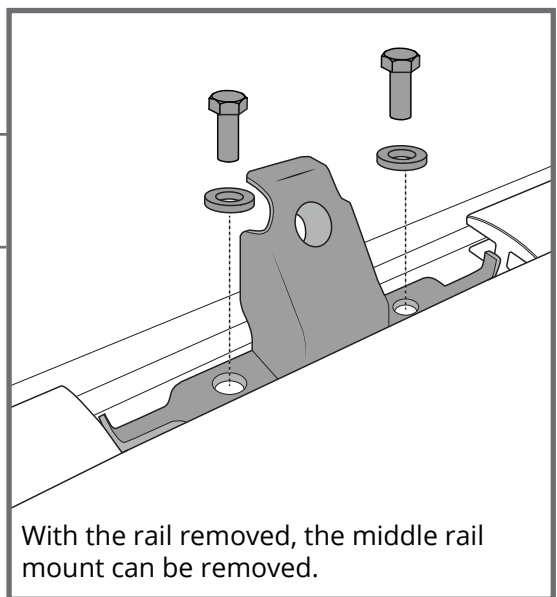
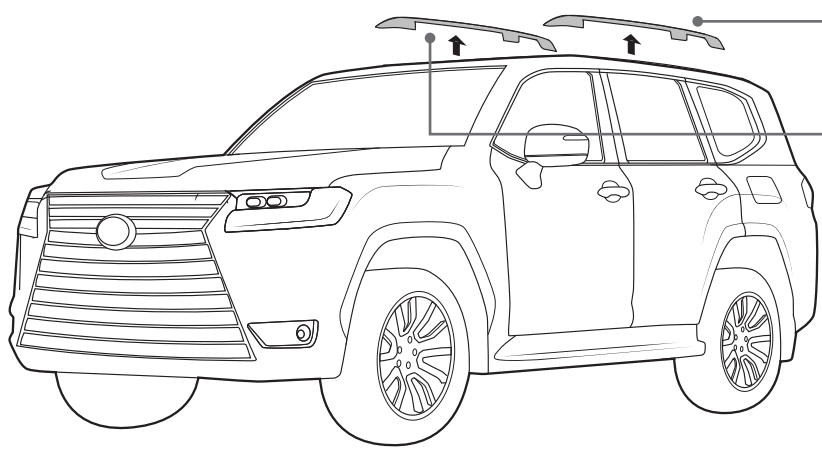

Clean the roof where the factory rail or cap was removed.

(A - OPTIONAL) Using butyl mastic, apply the sealant to all exposed holes in the roof, back in step 3.

(B) Add butyl patches to the exposed threads in the roof.

(C) Place rubber washers over all the exposed threads in the roof gutter channel.

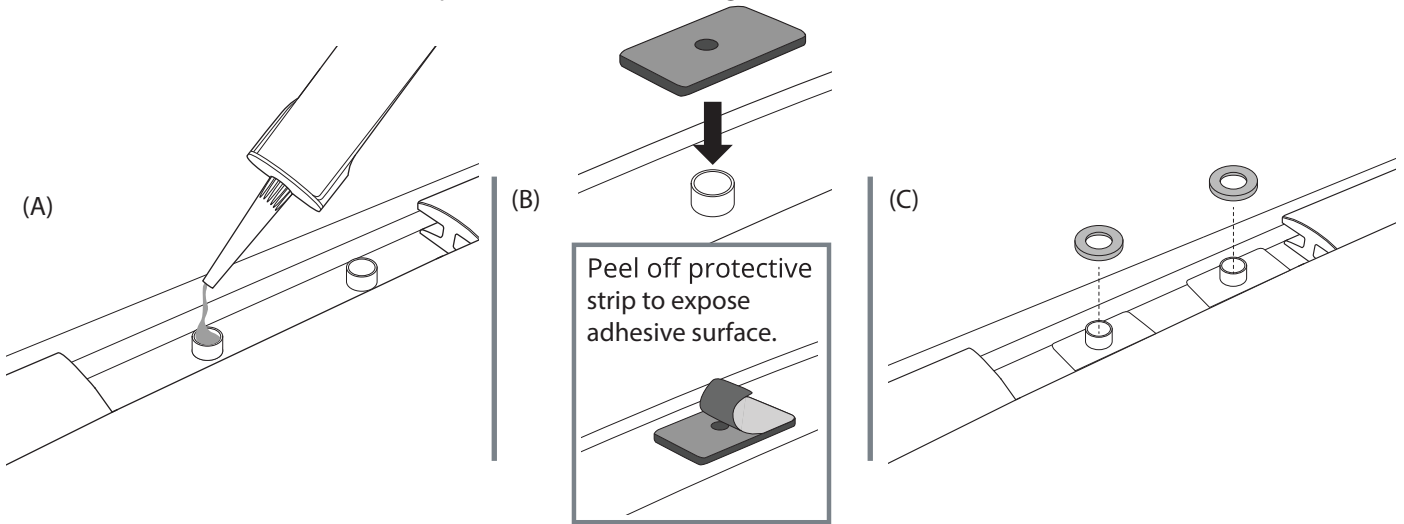

Assemble M8 hardware into the Ridge Mount rails as shown.

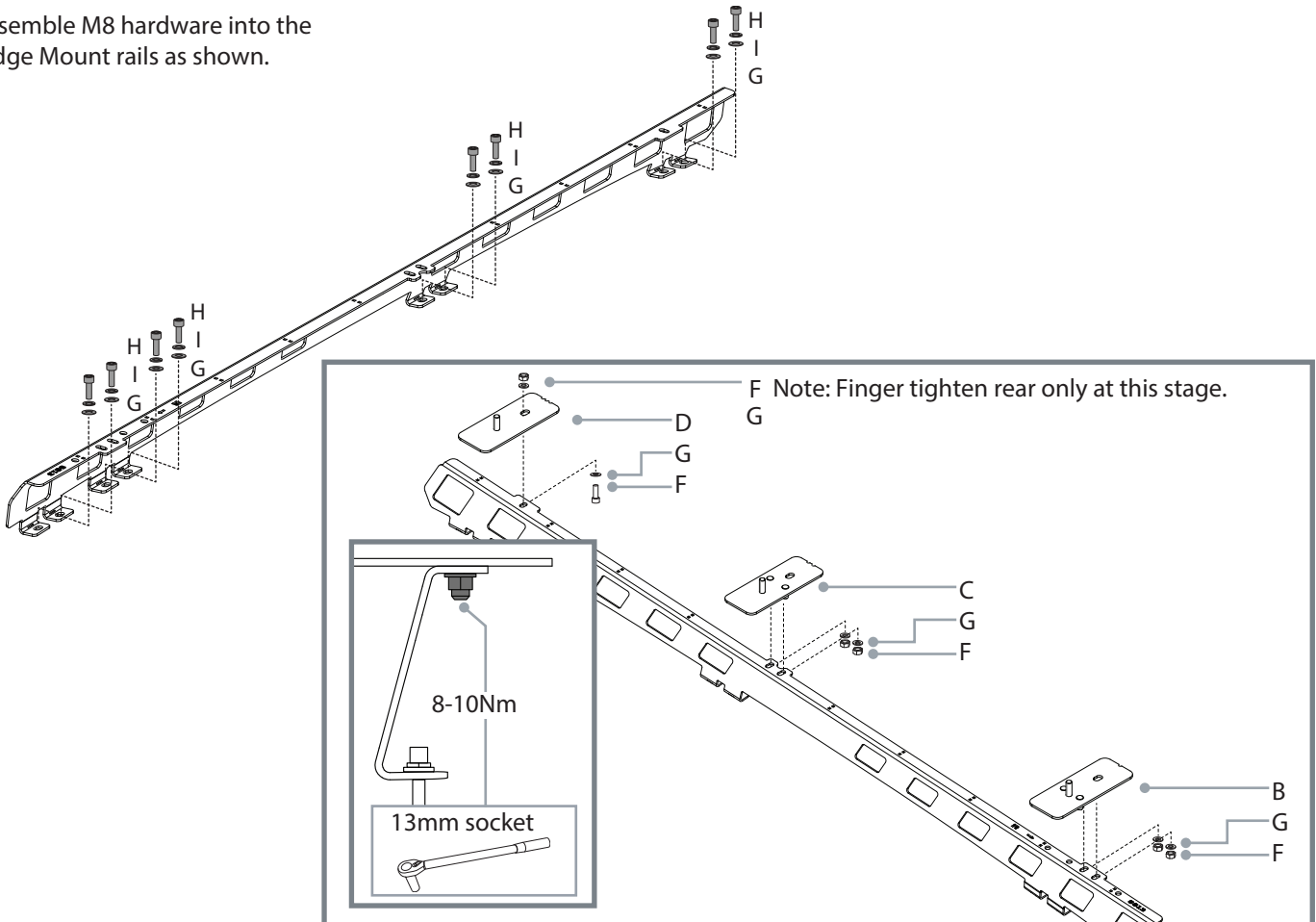

Place the Ridge Mount assembly onto the roof. The M8 hardware will pick up the factory threads in the roof.

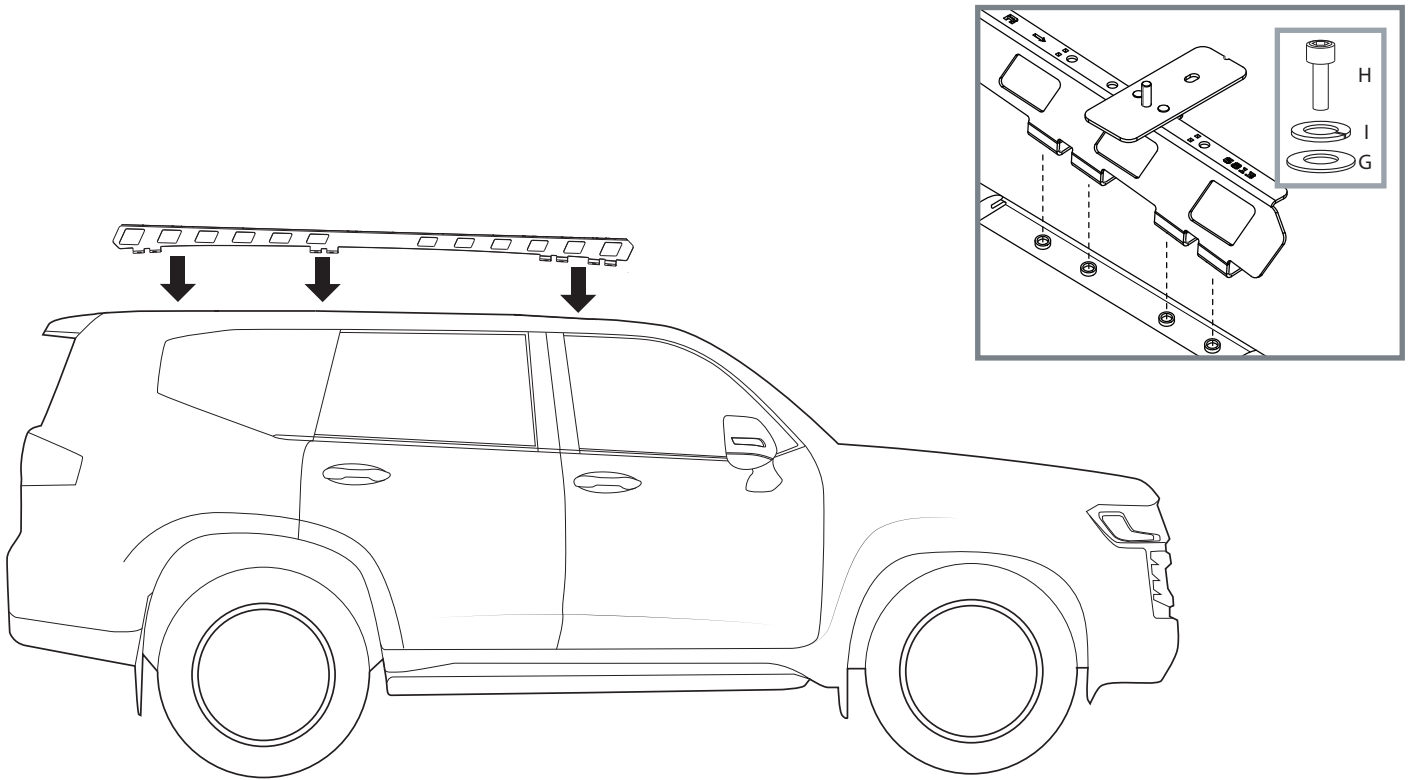

Tighten the M8 hardware with a 6mm allen key to 4-5Nm.
 Note: Access hardware through cutouts on side or holes located on top of the rail.

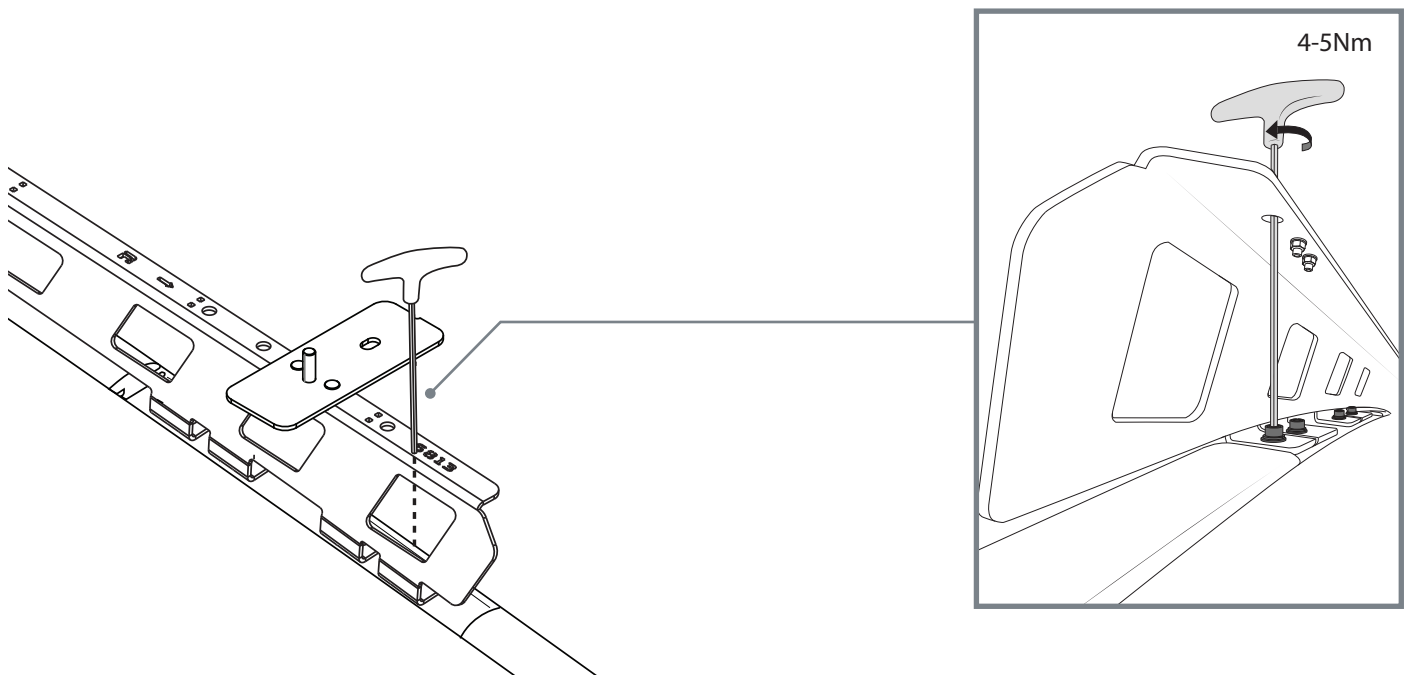

Install the Kaymar Platform as per corresponding instructions.

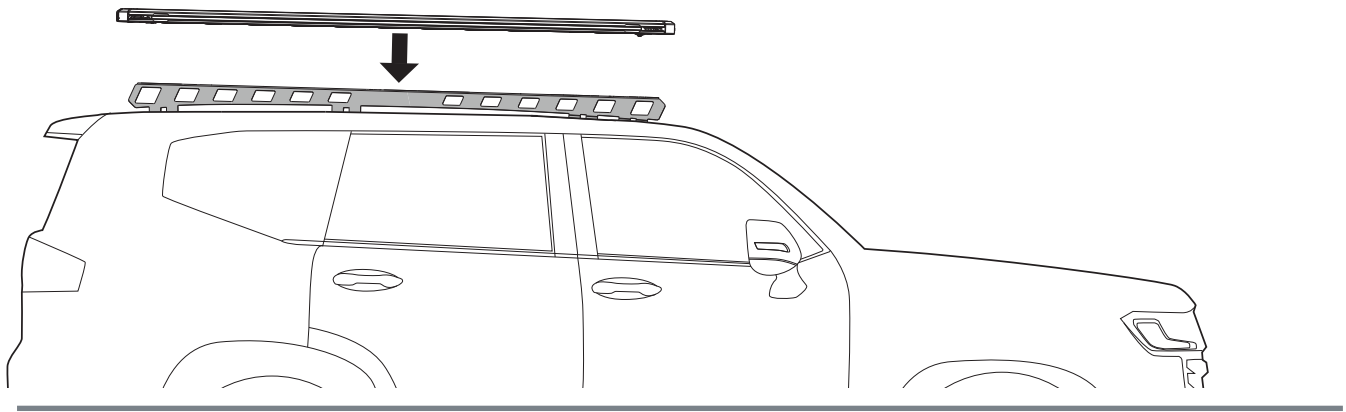
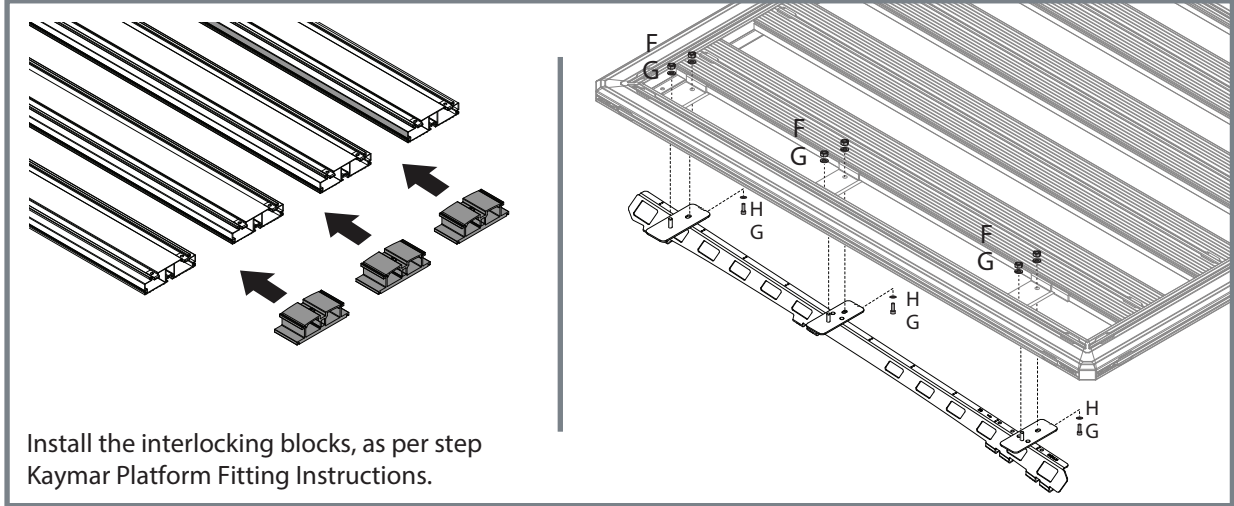

Note:

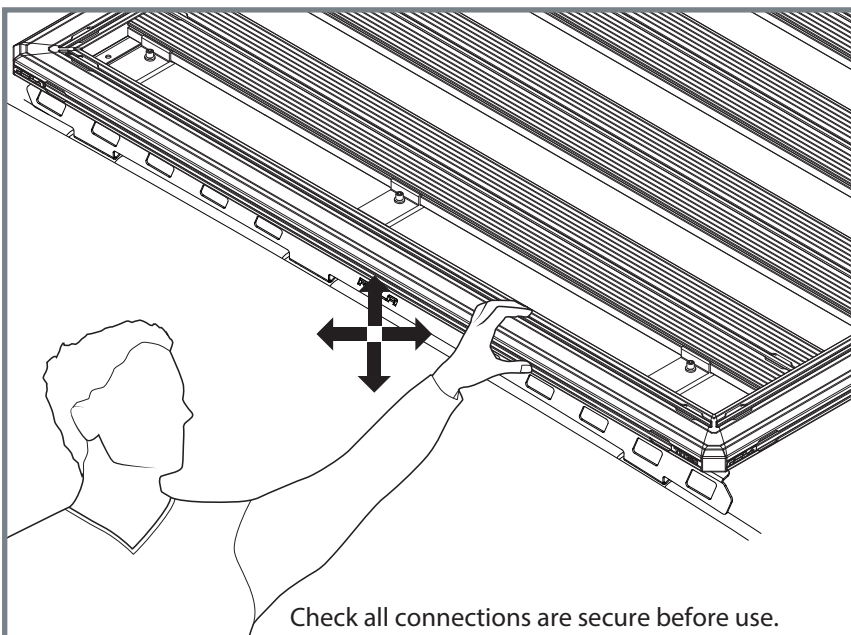

Wiring can be run and secured on the underside of the mount rail as shown.

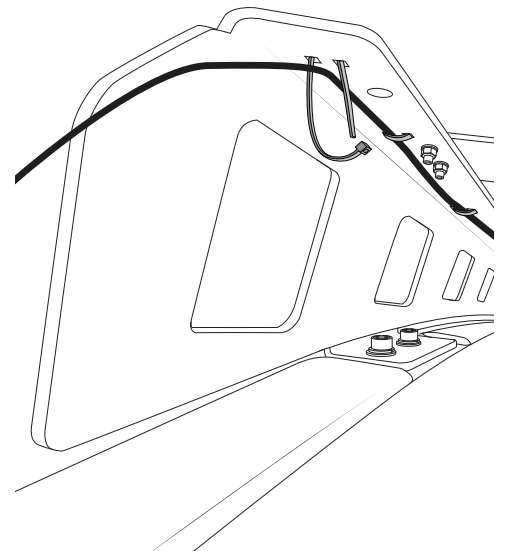

IMPORTANT - READ BEFORE USE**Please ensure the system is fitted in accordance with the fitting instructions.**

It is important that you observe all outlined below.

**LOAD RECOMMENDATIONS**

- Routinely and regularly check the proper functioning of the system. Check all fixtures at regular intervals.
- Do not use an automatic carwash with system installed.
- Maximum load capacity of the system is 661lbs/300kg under static conditions.
- Maximum load capacity of the system is 220lbs/100kg under dynamic including off-road conditions.
- Do not exceed vehicle manufacturers recommended load rating if it is lower than the maximum load capacity specified in this document (i.e., 220lbs/100kg).
- Ensure any load carried is evenly distributed.
- Actual load on vehicle Roof (Refer to owner's manual) = Weight of Roof rack system / Ridge Mount + Weight of Platform + Weight of cargo.
- Actual load on rack system (Refer to product instructions) = Platform weight + cargo.

WARRANTY INFORMATION

For full Warranty details refer to Kaymar website.

Kaymar.com.au

NOTE

All content subject to APG copyright.