

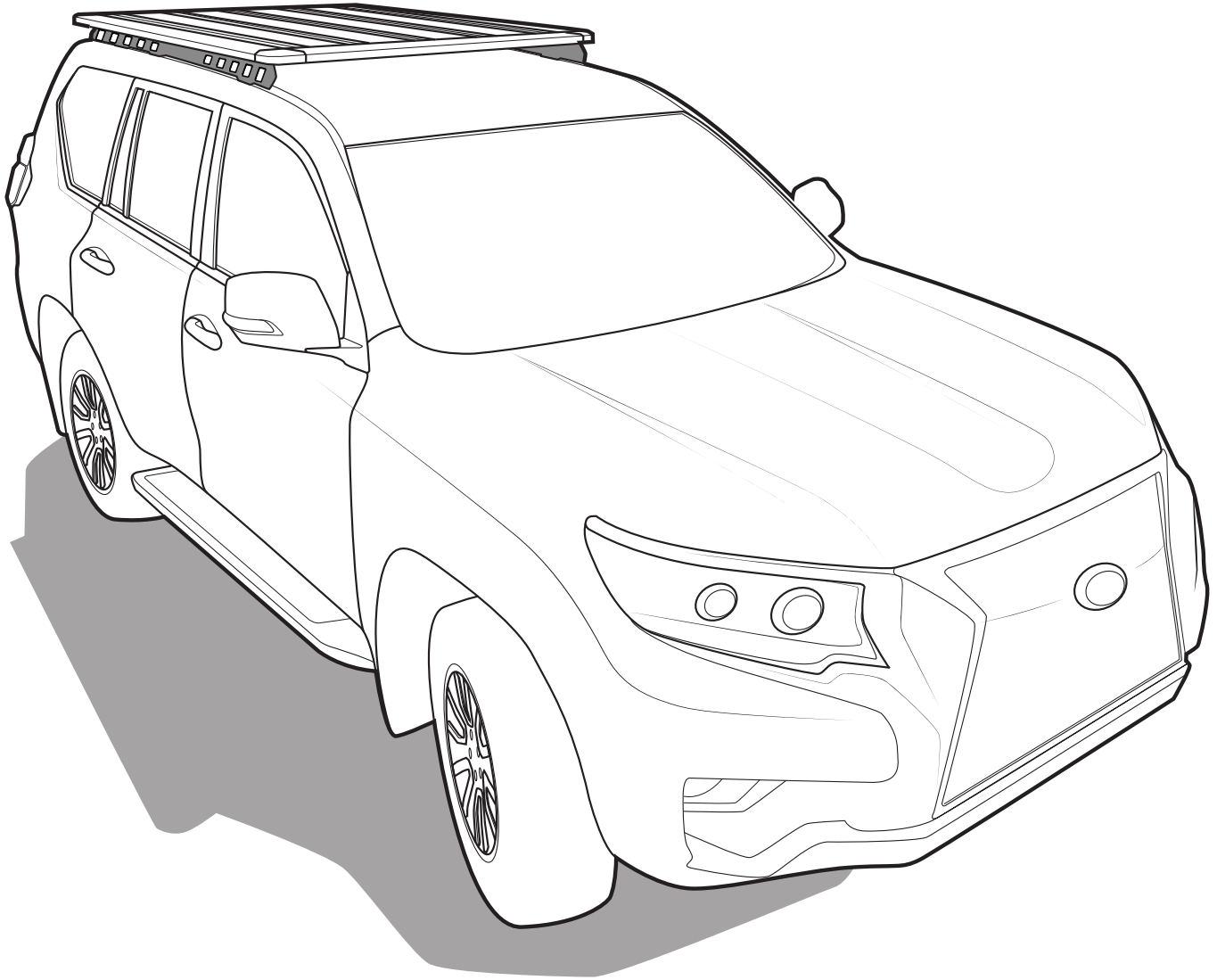







# KAYMAR

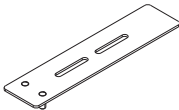

Read this full instruction prior to commencing assembly and fitment of Ridge Mount system.

CONTENT - CHECK ALL PARTS ARE CORRECT BEFORE PROCEEDING

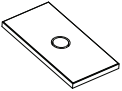
A		Ridge Mount (Pair)	1
B		Stud Plate	6
C		M8x30mm Cap Screw	12
D		M8 Spring Washer	12
E		M8x17mm Flat Washer	48
F		M8 Nyloc Nut	24
G		M8x25mm Cap Screw	12
H		Rubber Washer	12
I		Butyl Patches	12

TOOLS REQUIRED

- 6mm allen tool.
- 13mm + 10mm socket wrench.
- Step ladder.
- Butyl mastic sealant.
- Flat blade screwdriver.

1

Move to the side of the vehicle. Use a step ladder to get access to the top of the vehicle.

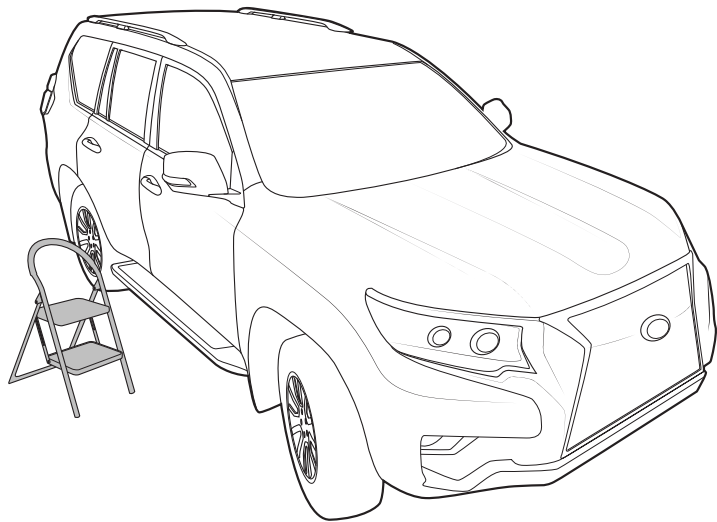

2

Using a trim removal tool, carefully pry off the rail covers at the front, middle and rear.

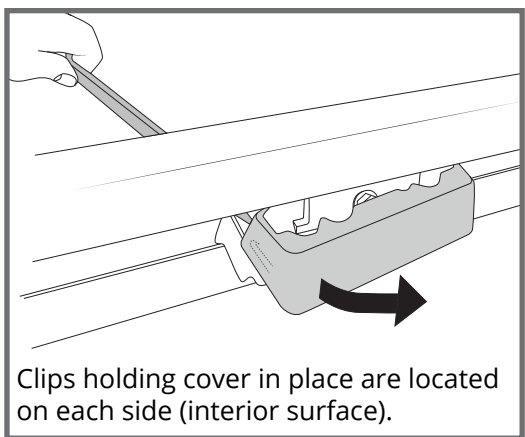

Clips holding cover in place are located on each side (interior surface).

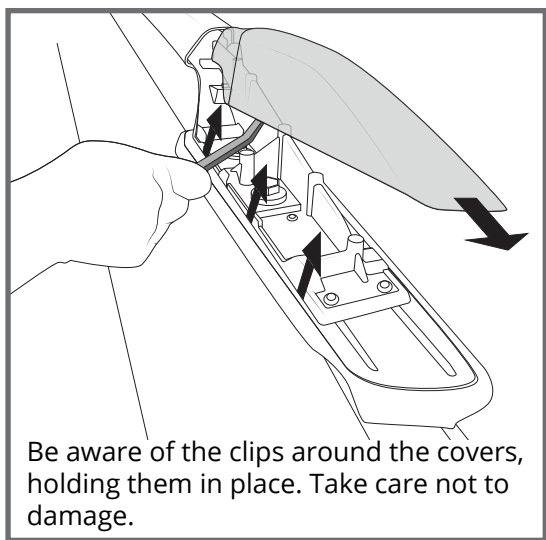

Be aware of the clips around the covers, holding them in place. Take care not to damage.

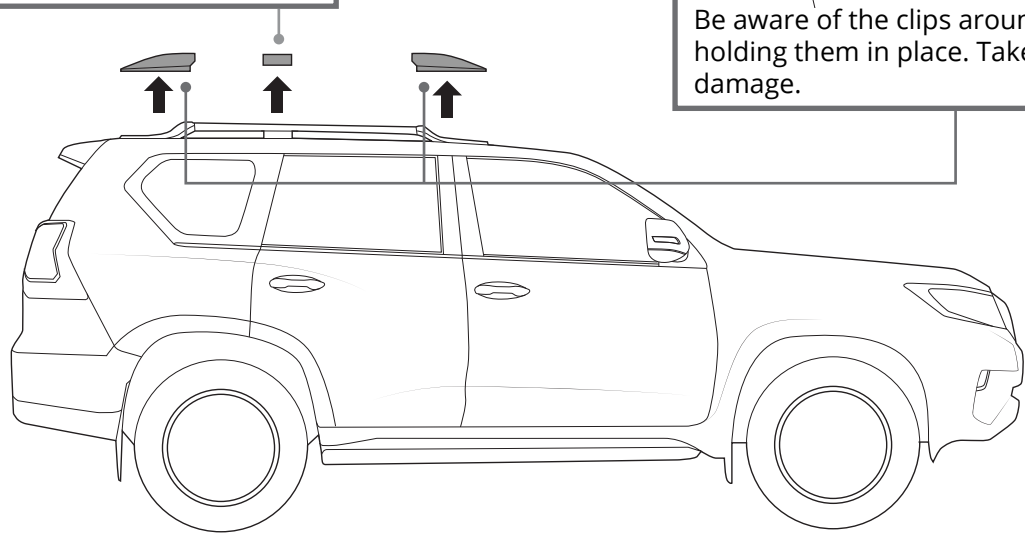

3

Using a 13mm socket wrench, carefully remove the bolts holding the rail in place.

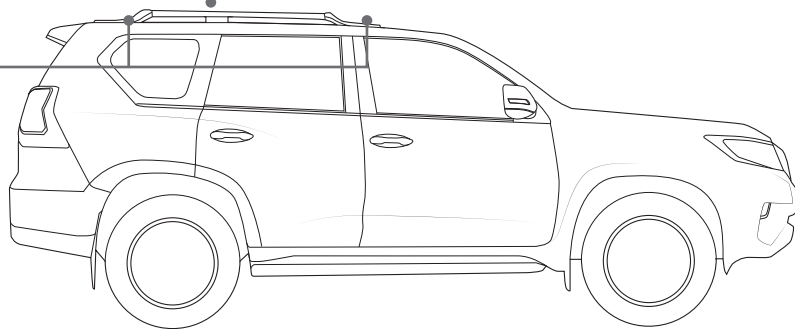
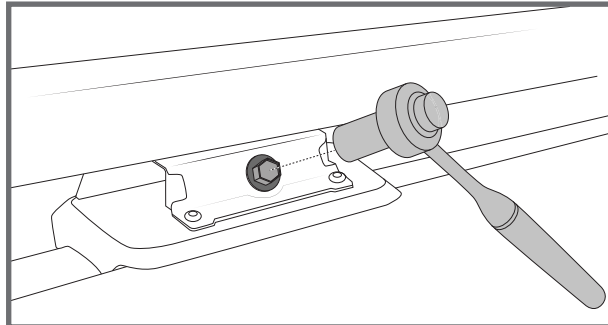
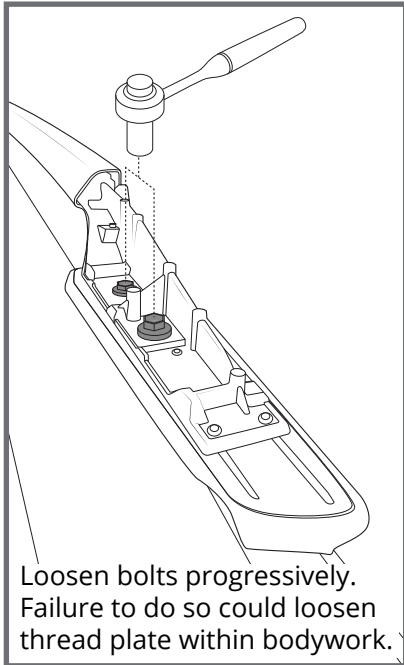

4

Carefully remove the factory rails. Clean the roof of the vehicle thoroughly.

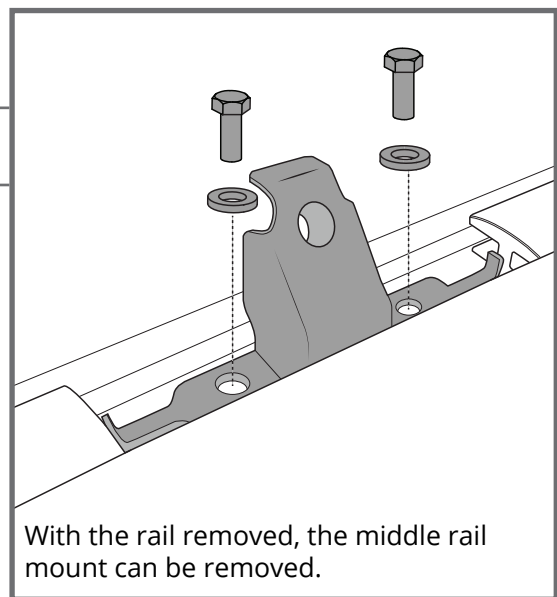
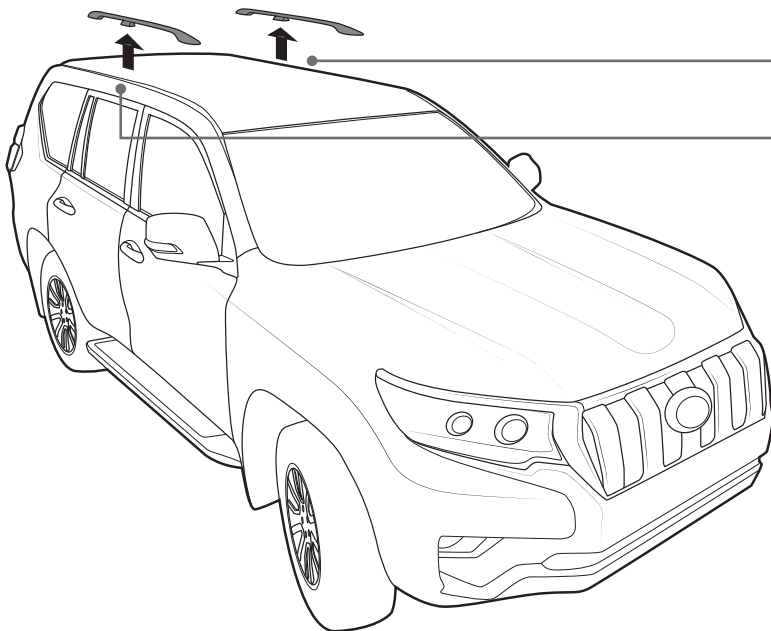

Clean the roof where the factory rail or cap was removed.

(A - OPTIONAL) Using butyl mastic, apply the sealant to all exposed holes in the roof, back in step 3.

(B) Add butyl patches to the exposed threads in the roof.

(C) Place rubber washers over all the exposed threads in the roof gutter channel.

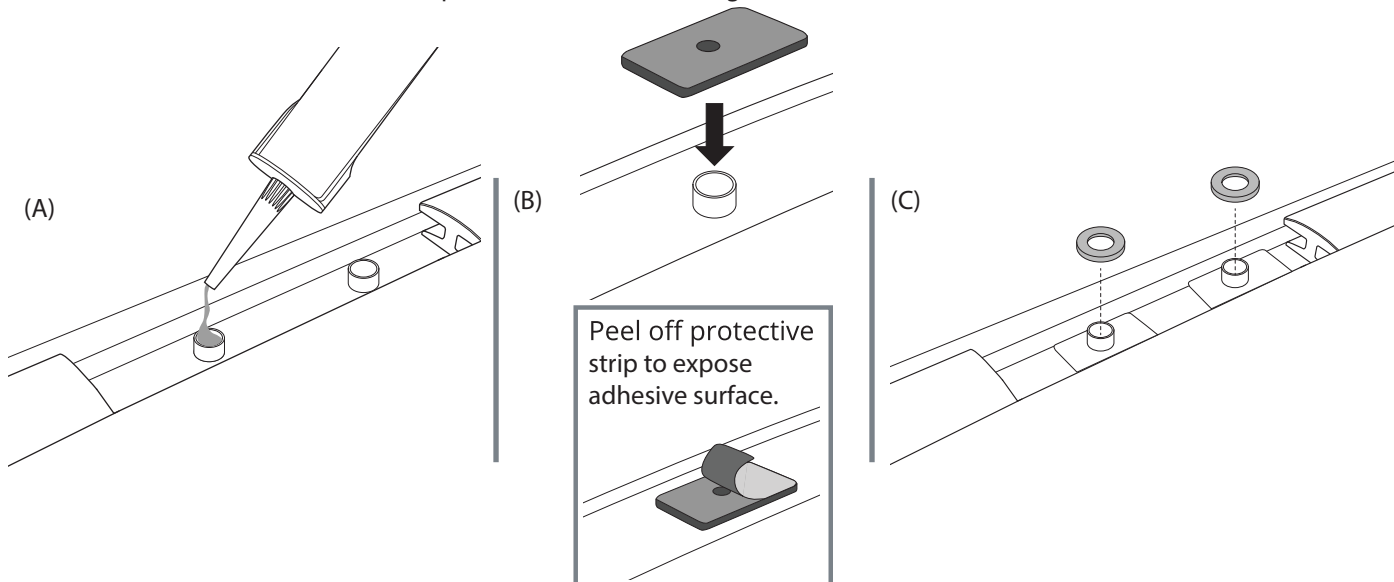

Assemble M8 hardware into the Ridge Mount rails as shown.

Place the Ridge Mount assembly onto the roof. The M8 hardware will pick up the factory threads in the roof.

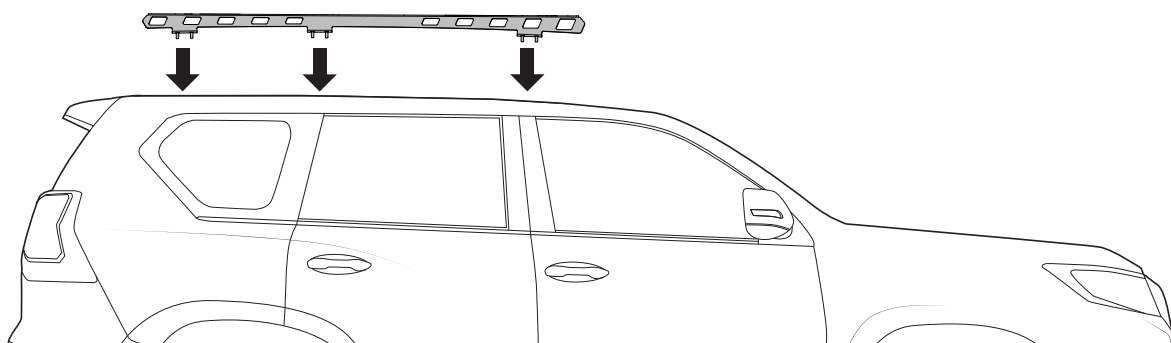
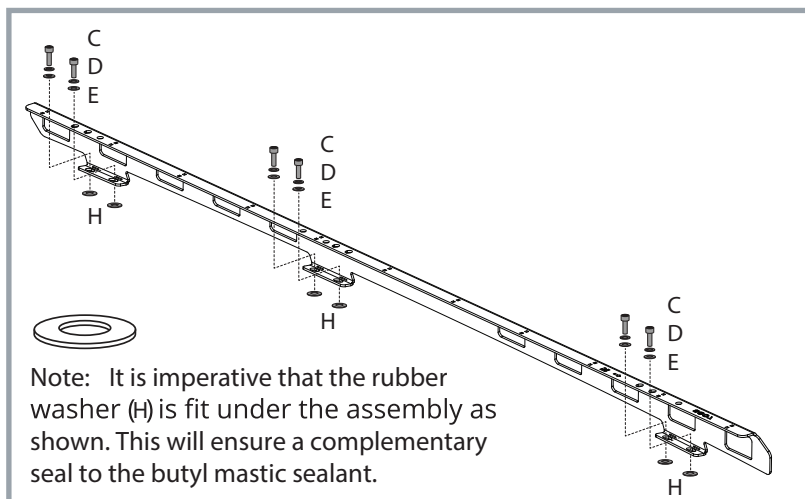

Tighten the M8 hardware with a 6mm allen key to 4-5Nm.

Note: Access hardware through cutouts on side or holes located on top of the rail.

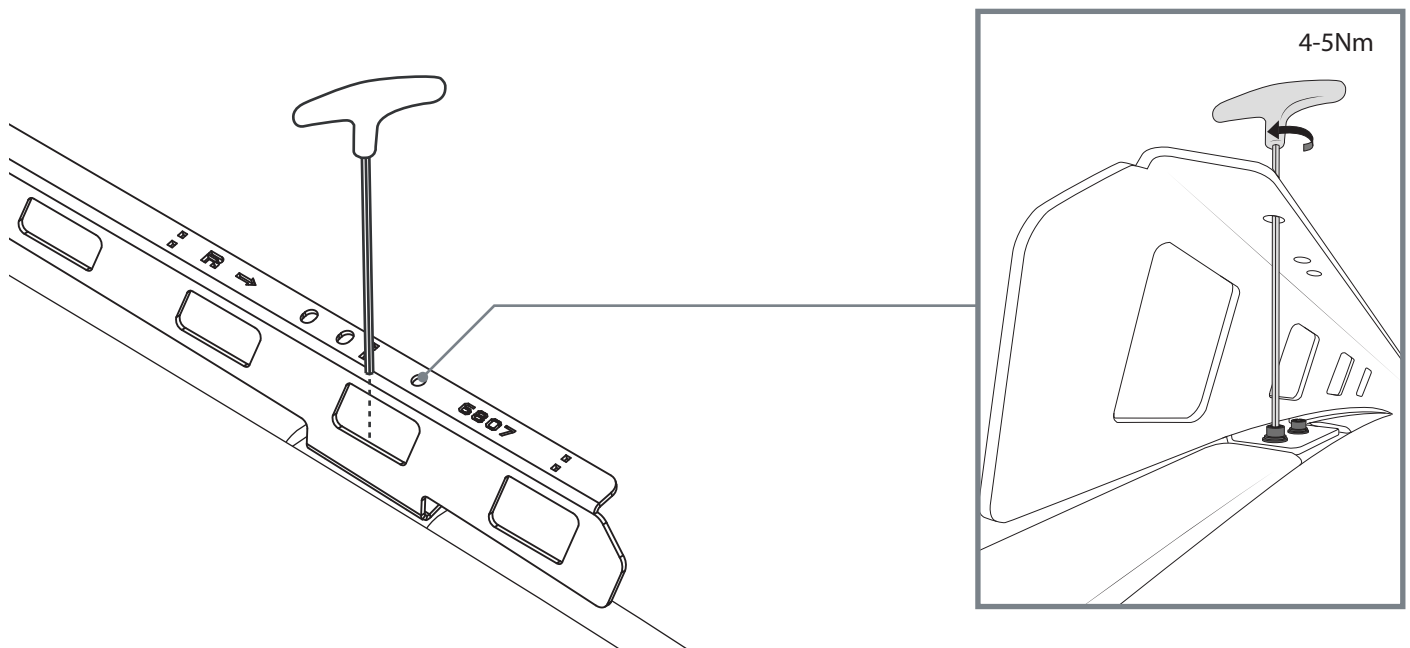

Assemble the stud plates and corresponding hardware onto the system. Tighten in place.

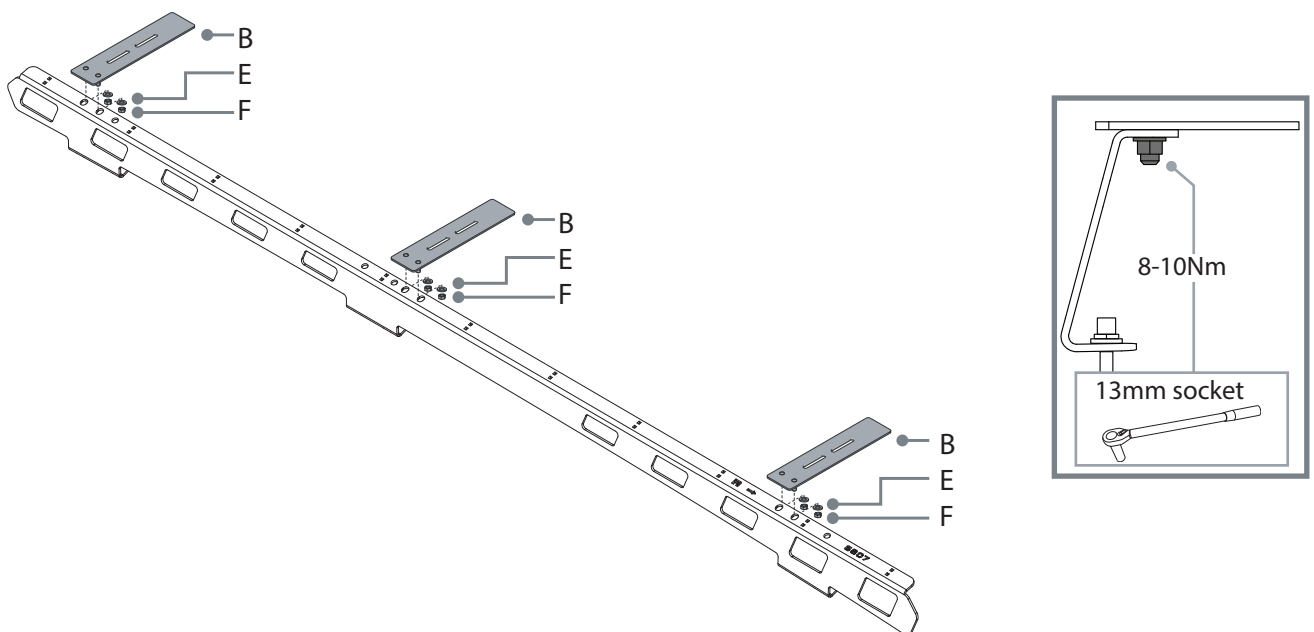

Install the Kaymar Platform as per corresponding instructions.

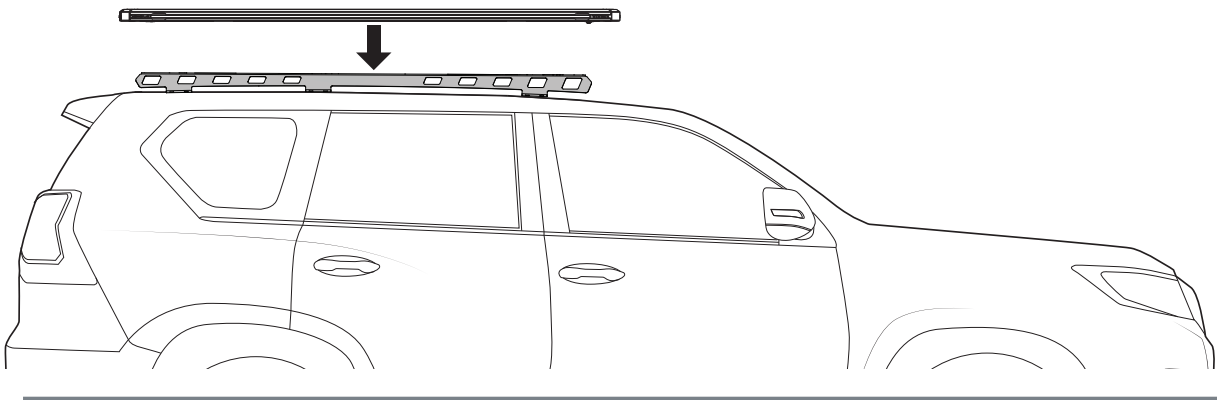
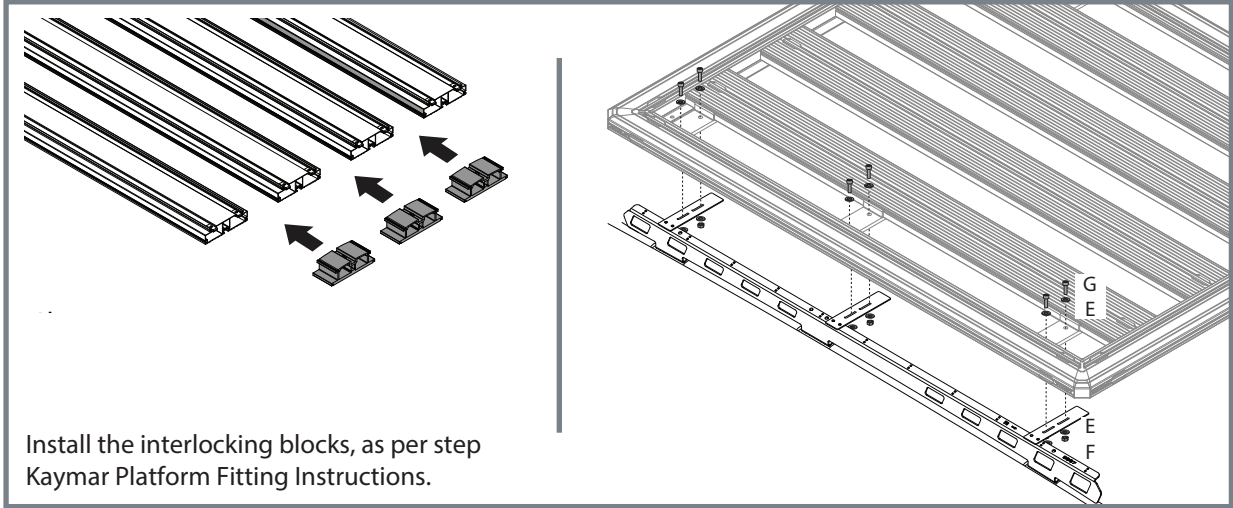

Note:

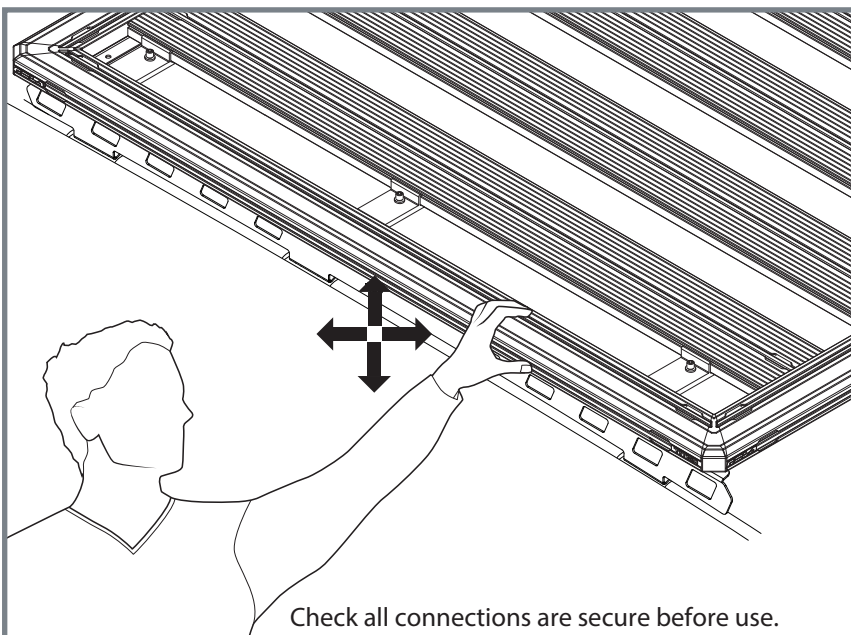

Wiring can be run and secured on the underside of the mount rail as shown.

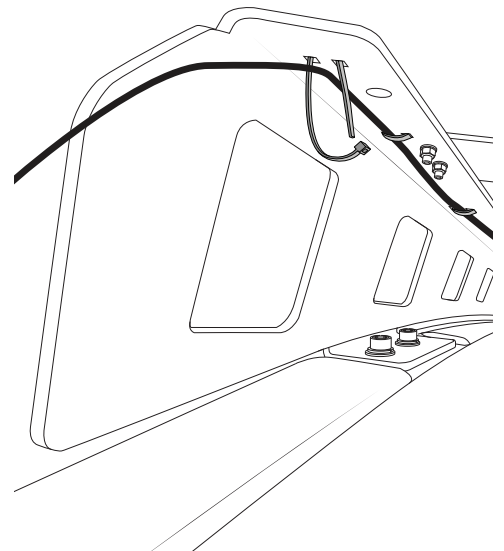

**IMPORTANT - READ BEFORE USE****Please ensure the system is fitted in accordance with the fitting instructions.**

It is important that you observe all outlined below.

**LOAD RECOMMENDATIONS**

- Routinely and regularly check the proper functioning of the system. Check all fixtures at regular intervals.
- Do not use an automatic carwash with system installed.
- Maximum load capacity of the system is 661lbs/300kg under static conditions.
- Maximum load capacity of the system is 220lbs/100kg under dynamic including off-road conditions.
- Do not exceed vehicle manufacturers recommended load rating if it is lower than the maximum load capacity specified in this document (i.e., 220lbs/100kg).
- Ensure any load carried is evenly distributed.
- Actual load on vehicle Roof (Refer to owner's manual) = Weight of Roof rack system / Ridge Mount + Weight of Platform+ Weight of cargo.
- Actual load on rack system (Refer to product instructions) = Platform weight + cargo.

**WARRANTY INFORMATION**

For full Warranty details refer to Kaymar website.

Kaymar.com.au

**NOTE**

All content subject to APG copyright.