

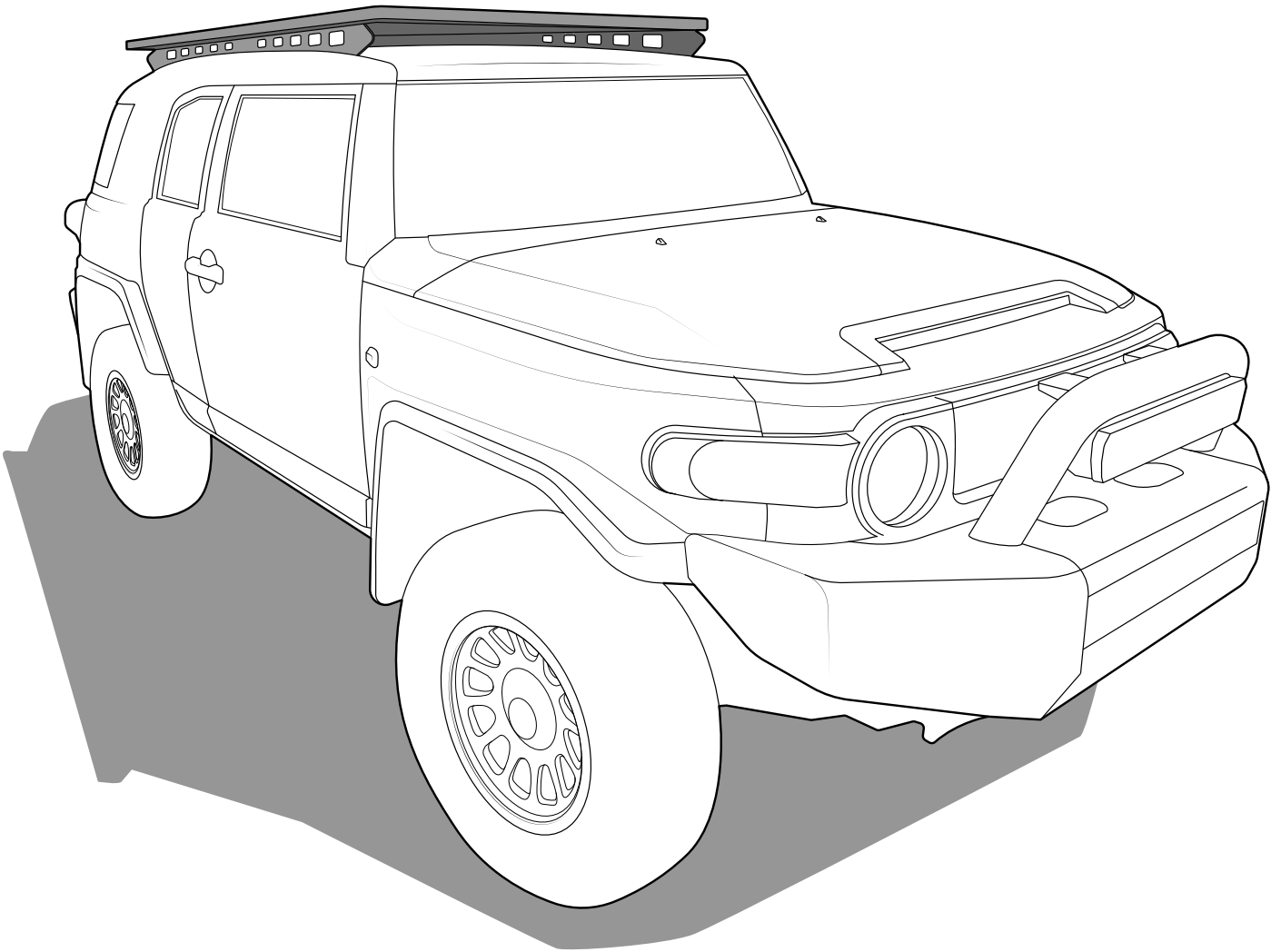







KAYMAR

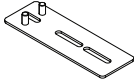

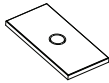
Read this full instruction prior to commencing assembly and fitment of Ridge Mount system.

CONTENT - CHECK ALL PARTS ARE CORRECT BEFORE PROCEEDING

A		Ridge Mount (Pair)	1
B		Stud Plate	6
C		M8x30mm Cap Screw	12
D		M8 Rubber Washer	12
E		Butyl Patches	24
F		M8X25mm Cap Screw	12
G		M8 Washer	48
H		M8 Nyloc Nut	24

TOOLS REQUIRED

- 13 + 10mm socket wrench.
- 6mm allen tool.
- 13mm socket wrench.
- Flat blade screw driver.
- Trim tool.
- Step ladder.

1

Move to the side of the vehicle. Use a step ladder to get access to the vehicle roof.

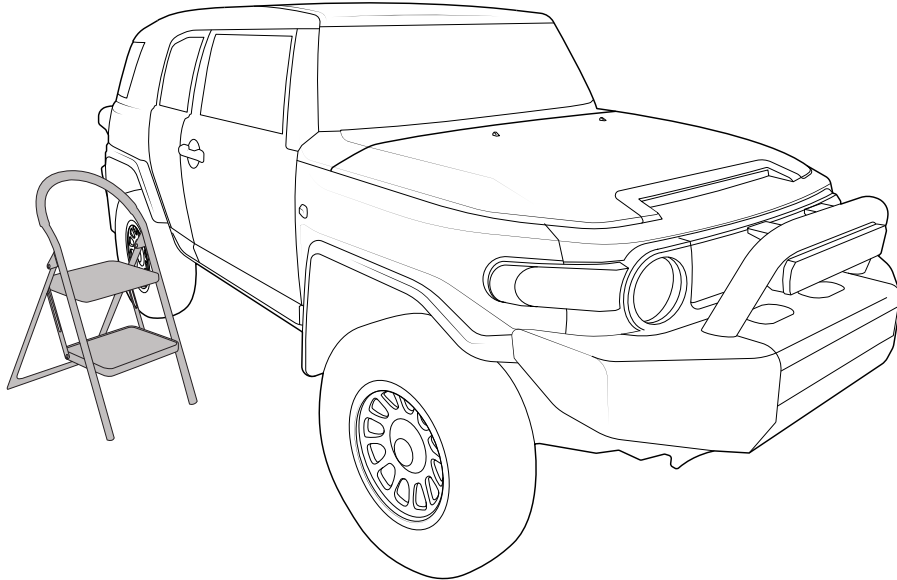

2

Carefully remove the 6 mounting point covers from the roof.

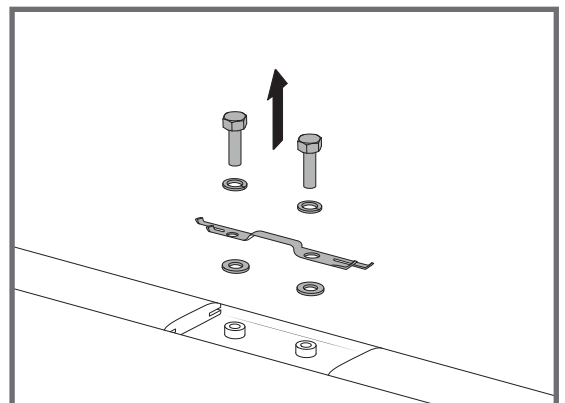
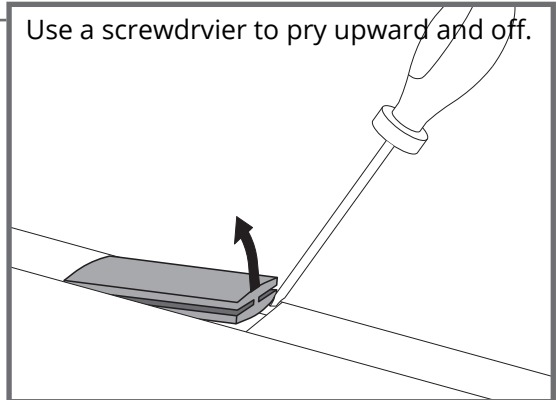
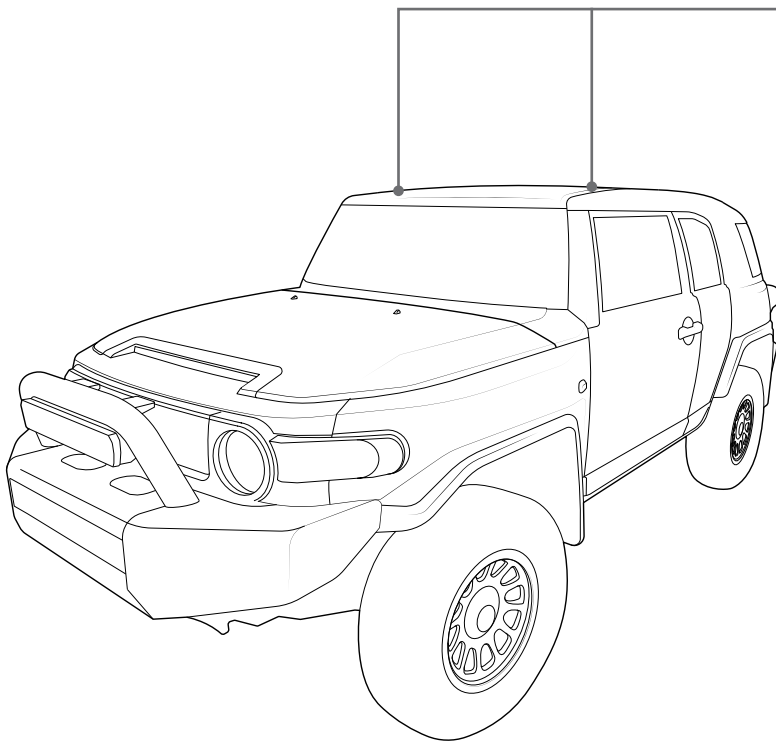

Clean the roof where the factory rail or cap was removed.

(A) OPTIONAL: Using butyl mastic, apply the sealant to all exposed holes in the roof, back in step 2.

(B) Add **2x butyl patches** to the exposed threads in the roof.

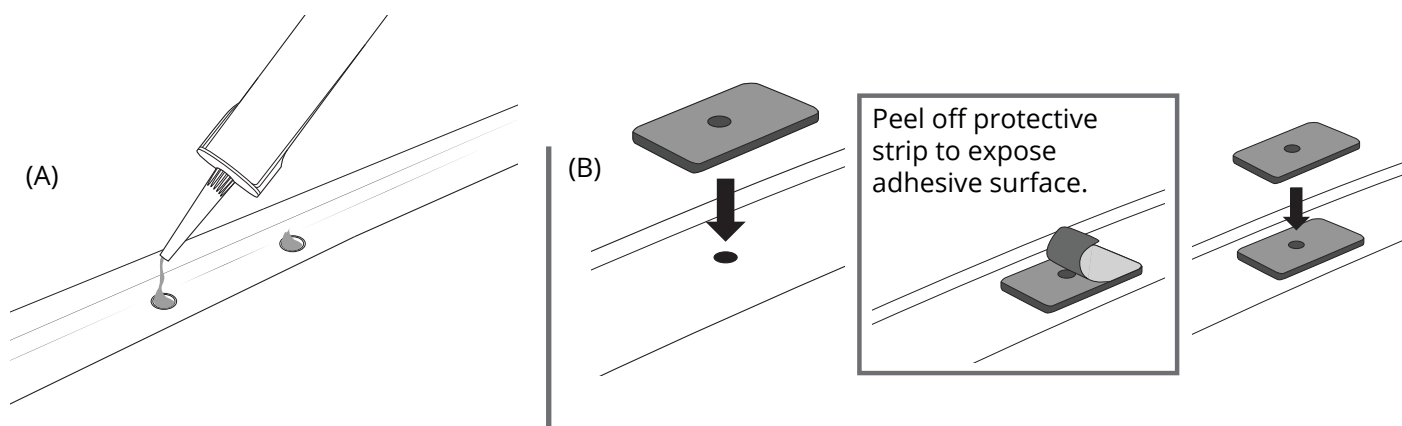

Assemble M6 hardware into the Ridge Mount as shown.

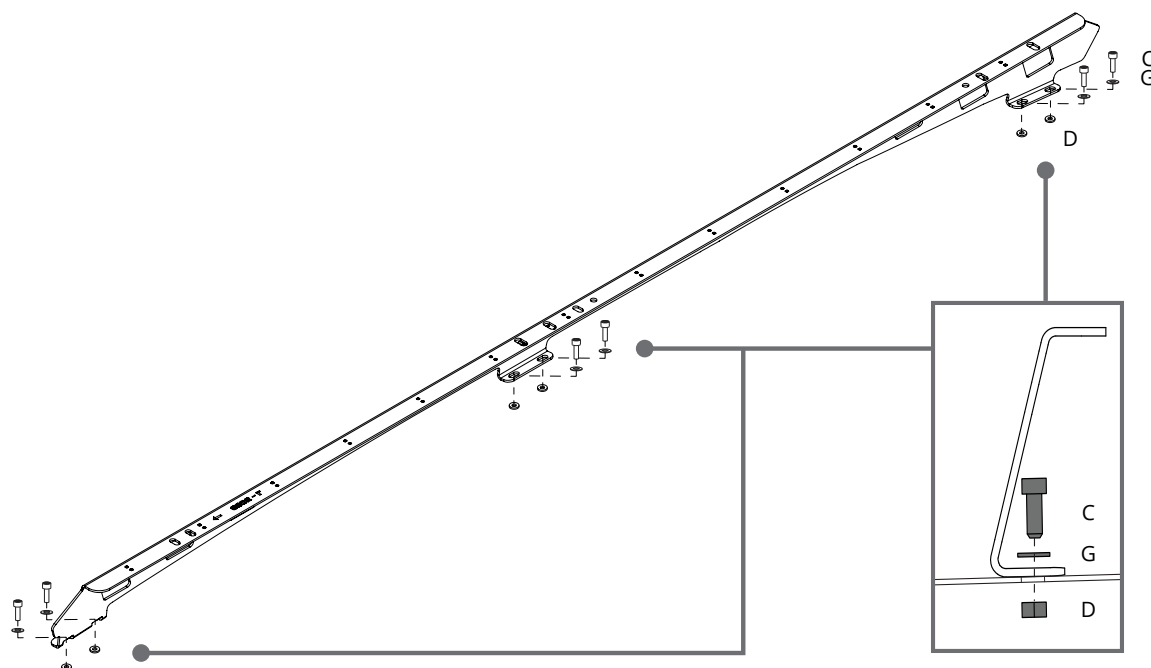

5

Place the Ridge Mount assembly onto the roof. The M8 hardware will pick up the factory threads in the roof.

Tighten the M6 hardware with a 6mm allen key to 8-10Nm.
Note: Access hardware through cutouts on side of the rail or located on top.

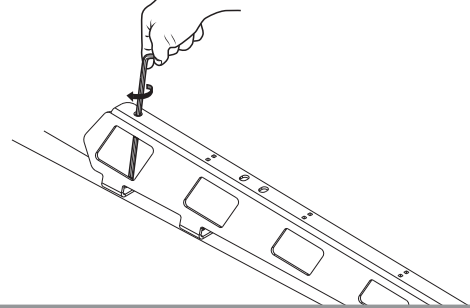
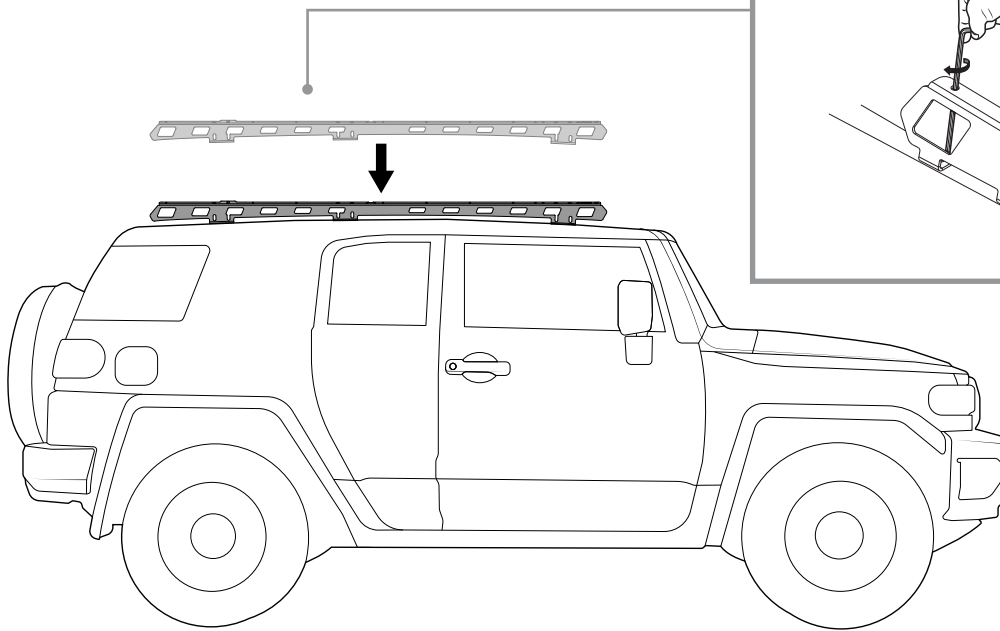

6

Install the stud plates as shown.

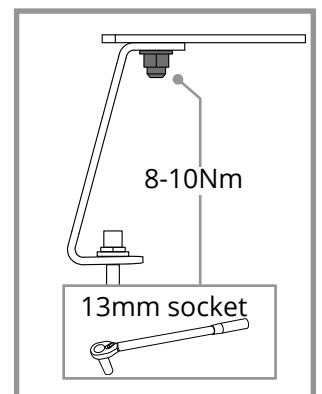
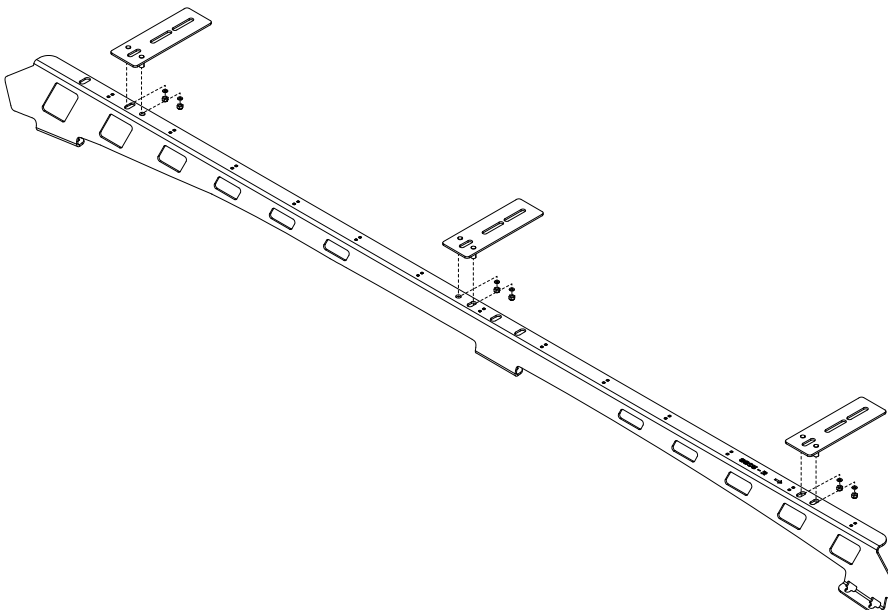

PLATFORM FITMENT

7

Install the Kaymar Platform as per corresponding instructions.

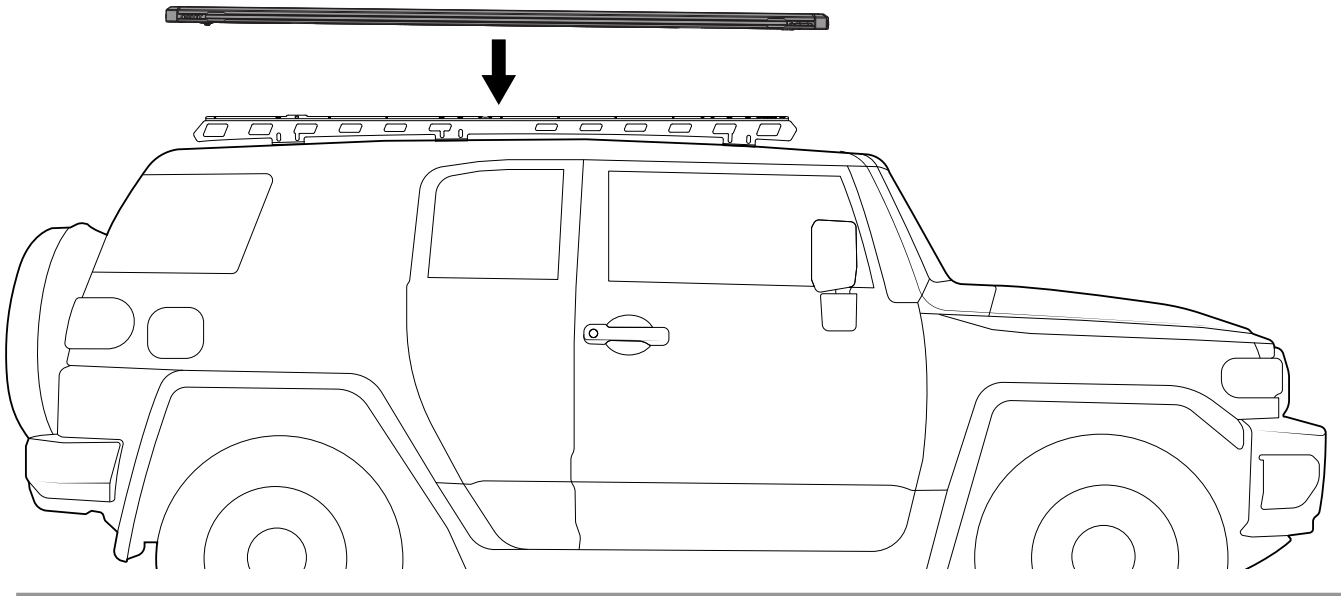
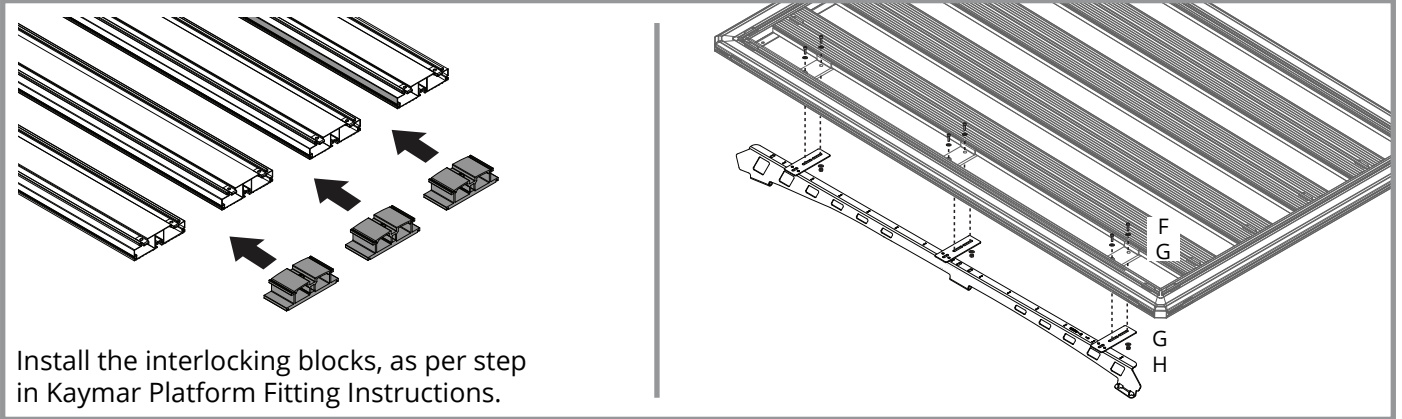

Note:

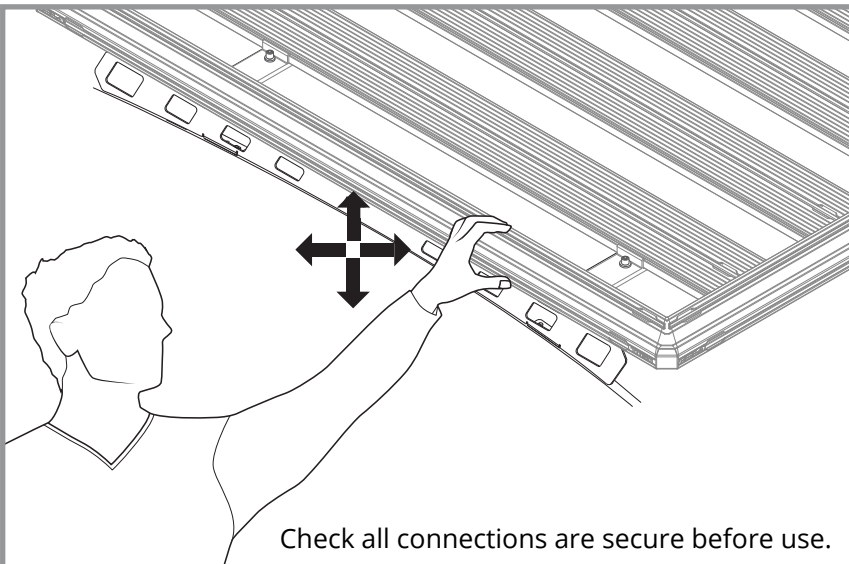

Wiring can be run and secured on the underside of the Ridge Mount rail as shown.

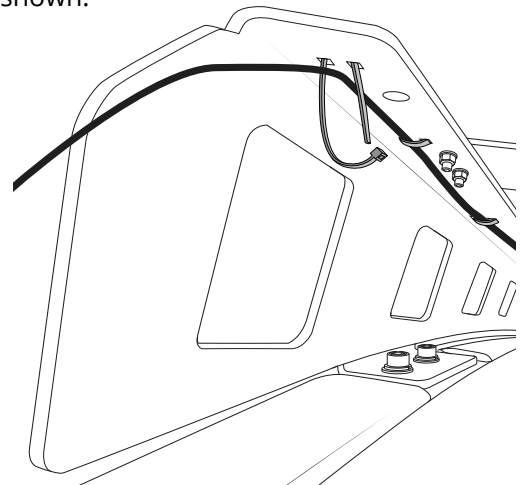

IMPORTANT - READ BEFORE USE

Please ensure the system is fitted in accordance with the fitting instructions.
It is important that you observe all outlined below.

**LOAD RECOMMENDATIONS**

- Routinely and regularly check the proper functioning of the system. Check all fixtures at regular intervals.
- Do not use an automatic carwash with system installed.
- Maximum load capacity of the system is 661lbs/300kg under static conditions.
- Maximum load capacity of the system is 220lbs/100kg under dynamic including off-road conditions.
- Do not exceed vehicle manufacturers recommended load rating if it is lower than the maximum load capacity specified in this document (i.e., 220lbs/100kg).
- Ensure any load carried is evenly distributed.
- Actual load on vehicle Roof (Refer to owner's manual) = Weight of Roof rack system / Ridge Mount + Weight of platform + Weight of cargo.
- Actual load on rack system (Refer to product instructions) = platform weight + cargo.

WARRANTY INFORMATION

For full Warranty details refer to Kaymar website.

Kaymar.com.au

NOTE

All content subject to APG copyright.