

KAYMAR

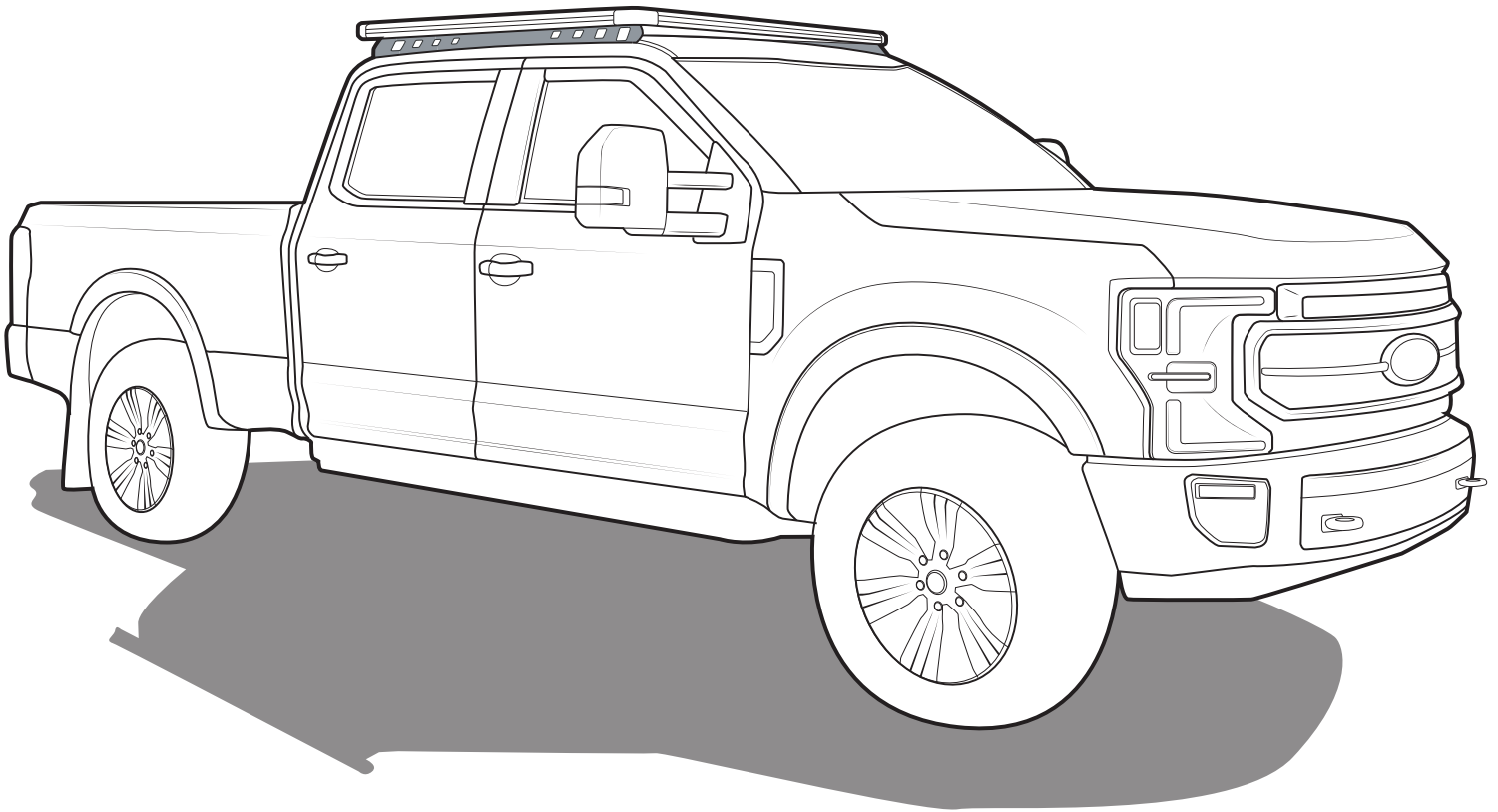







Ford F250 Crew Cab
Ford F350 Crew Cab
Ford F450 Crew Cab

Fourth Gen
2017 - 2022

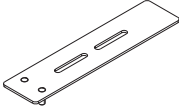
RIDGE MOUNT SYSTEM
RMK36877 - Issue 01

Read this full instruction prior to commencing assembly and fitment of Ridge Mount system.

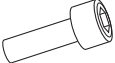
CONTENT - CHECK ALL PARTS ARE CORRECT BEFORE PROCEEDING

A		Ridge Mount (Pair)	1
B		Stud Plate	4
C		M5x20mm Cap Screw	12
D		M5 Flat Washer	12
E		Rubber Washer	12
F		M8 Nyloc Nut	16
G		M8x25mm Cap Screw	8
H		M8x17mm Flat Washer	24
I		Butyl Patch	24

TOOLS REQUIRED

- 4mm and 6mm allen tool.
- 13mm socket wrench.
- Step ladder.
- Butyl mastic sealant.
- Snips.
- Trim tools.
- Flat blade screwdriver.

1

Move to the side of the vehicle. Use a step ladder to get access to the vehicle roof.

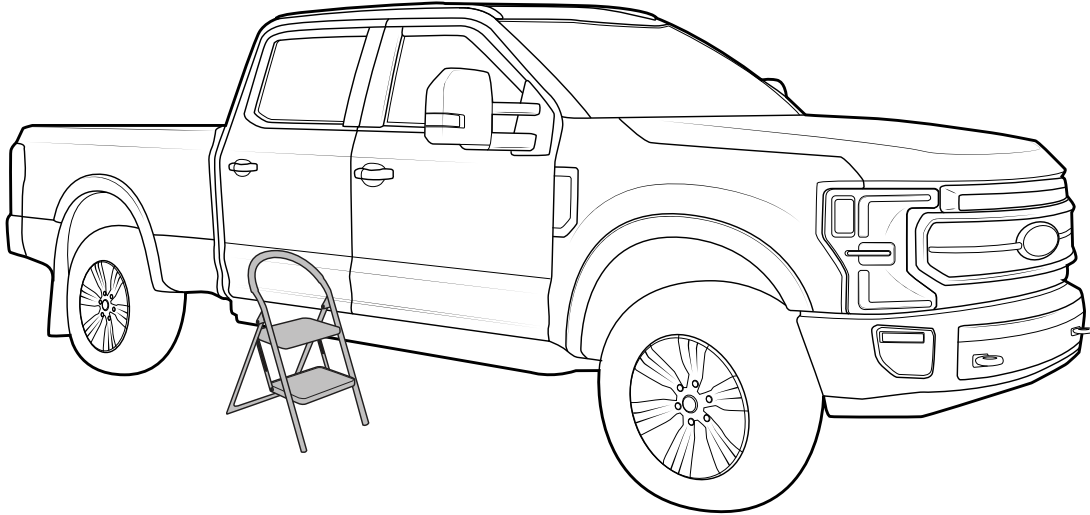

2

Near the front of the vehicle, carefully pry the roof gutter molding towards the outside of the vehicle. Lift the molding out, stopping at the rear tooling mark as shown.

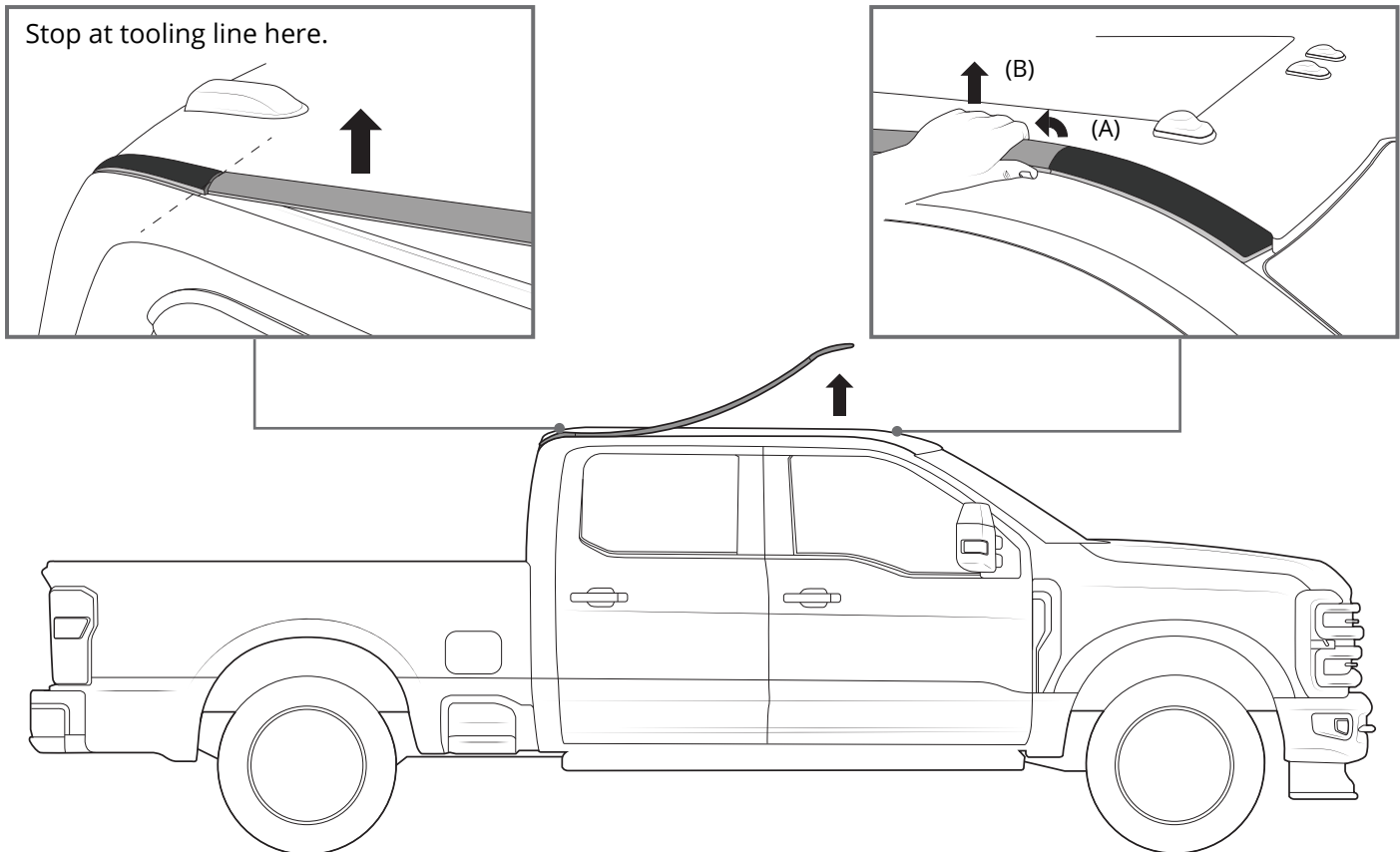

3

The clips holding the molding may require removal after it is pulled free. This can be done safely with trim tools.

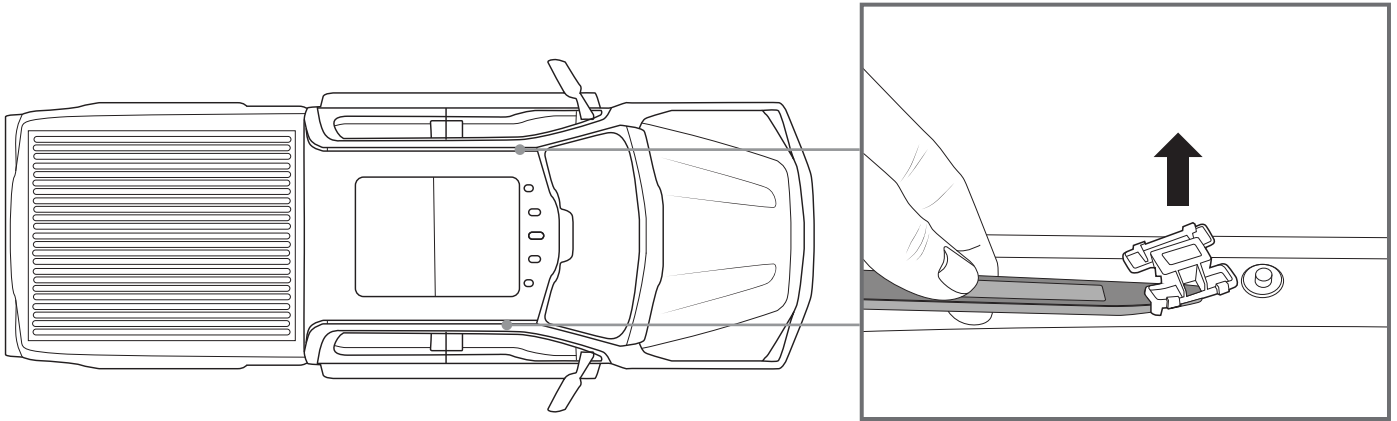

4

Using snips, carefully cut the molding along the tooling lines, front and rear.

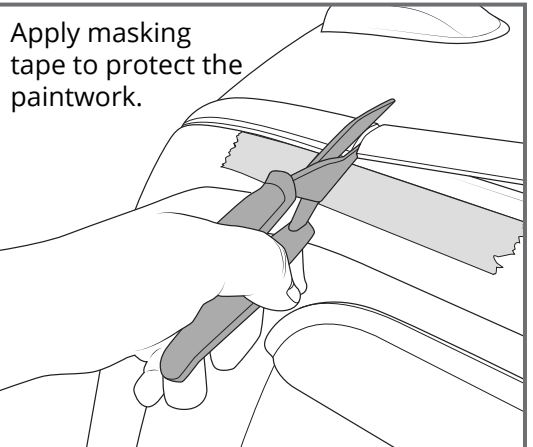
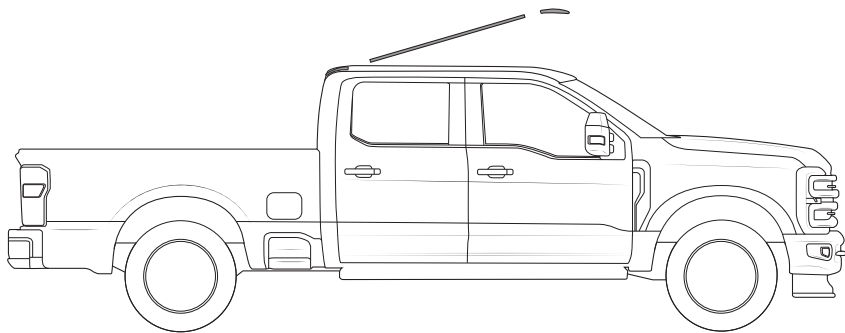

5

With a socket, remove the 1st, 3rd, 7th, 9th, 14th and 16th bolt in the roof gutter. Work from the front of the gutter backward.

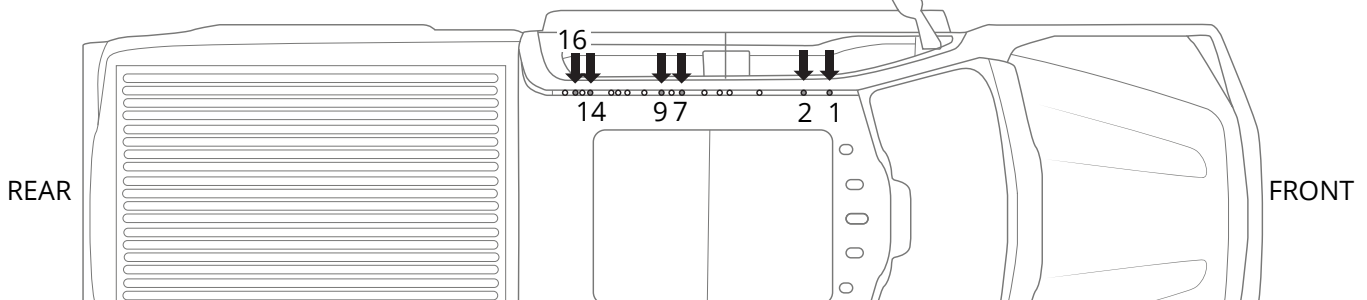
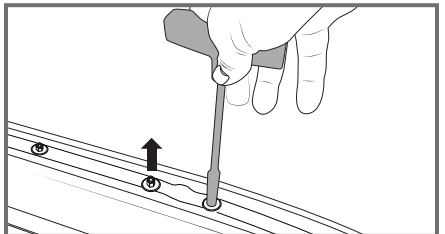

6

Apply butyl mastic to all exposed threads.

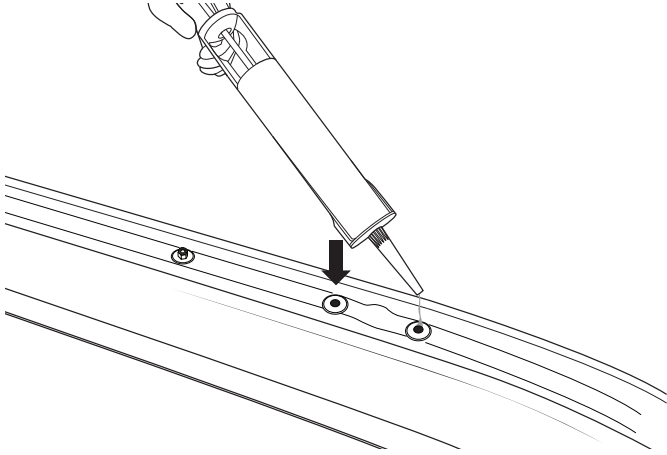

Once complete, install butyl patches over the threads.

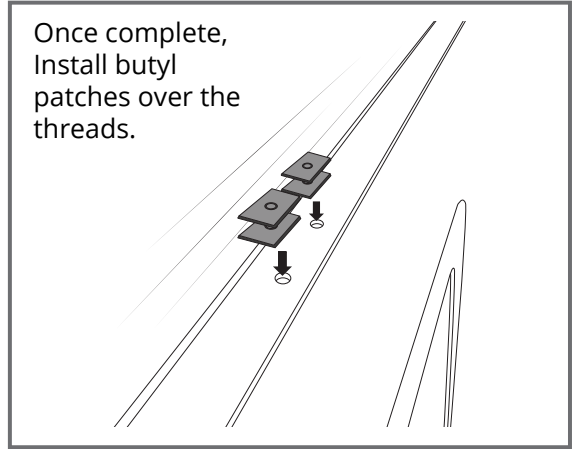

7

Apply butyl mastic at the front and rear of the gutter. The rear gutter molding can be lifted slightly for access.

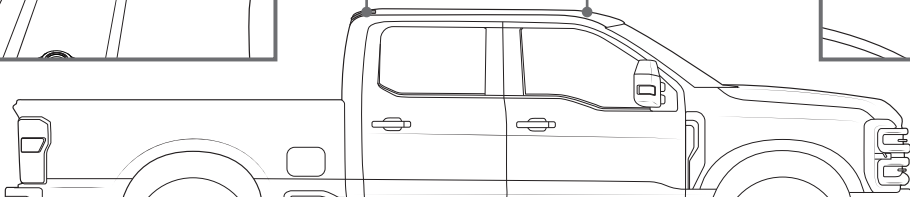
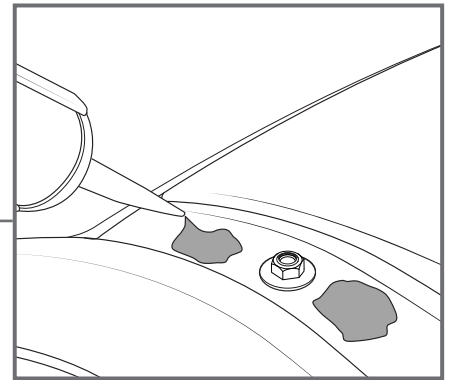
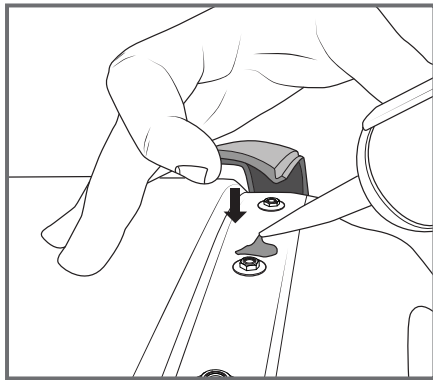

8

Using the sealant as an adhesive, place the cut out front and rear sections of the ditch back into place.

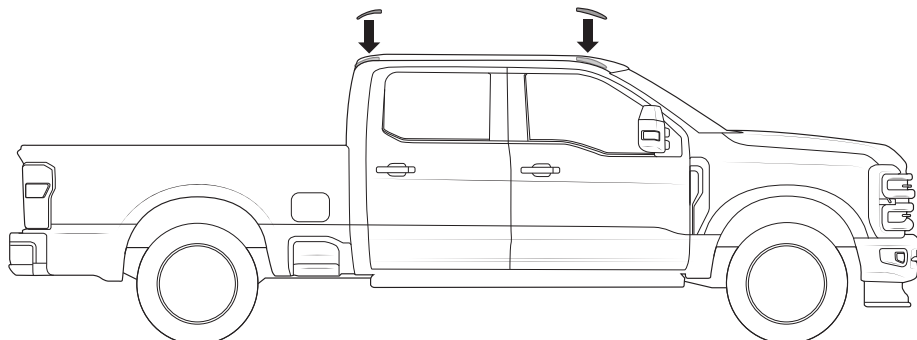

9

Assemble M6 hardware into the Ridge Mount as shown.

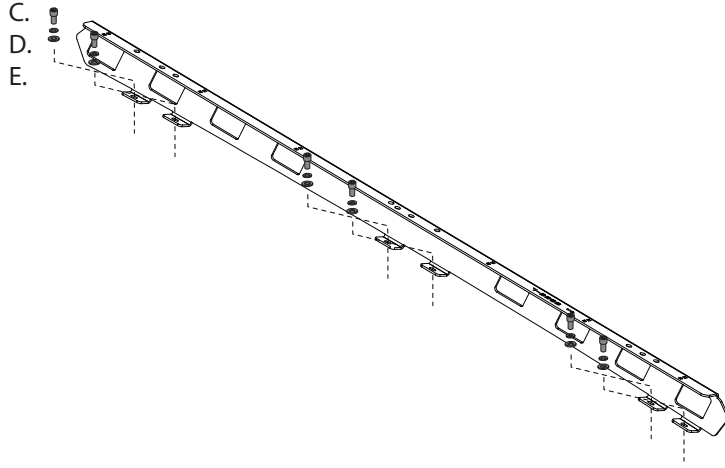

9

Place the Ridge Mount assembly onto the roof. The M5 hardware will pick up the threads exposed previous.

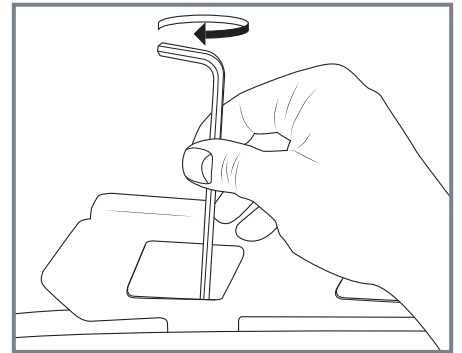
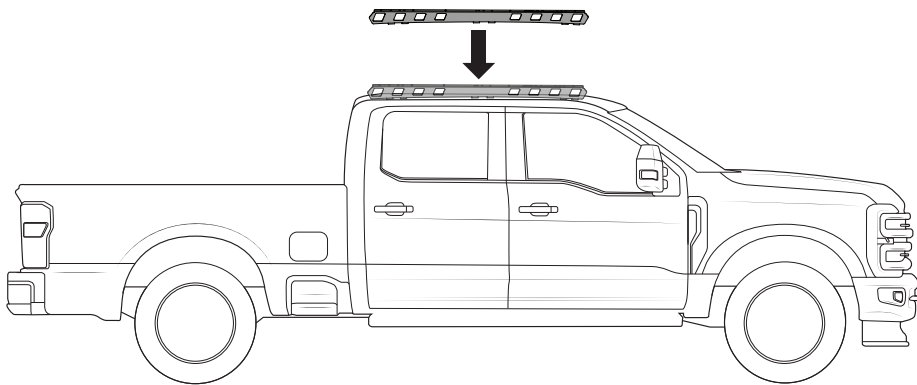

10

Install the stud plates.

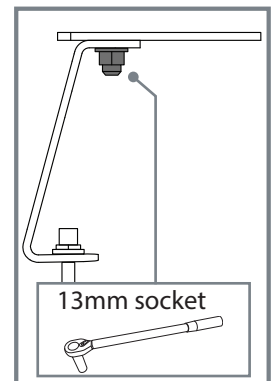
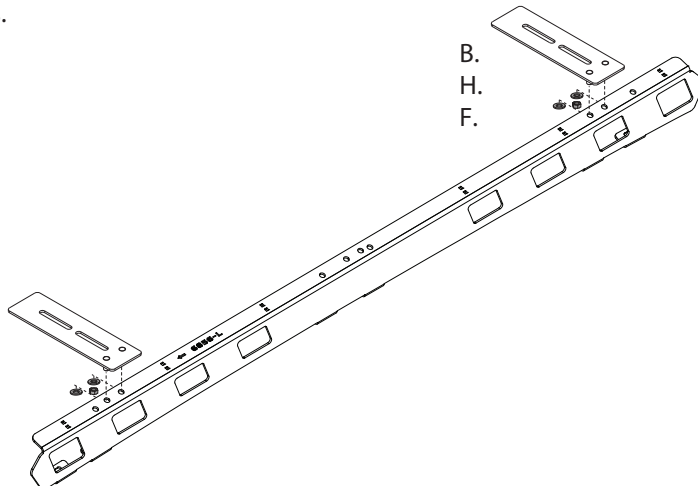

PLATFORM FITMENT

11

Install the Kaymar Platform as per corresponding instructions.

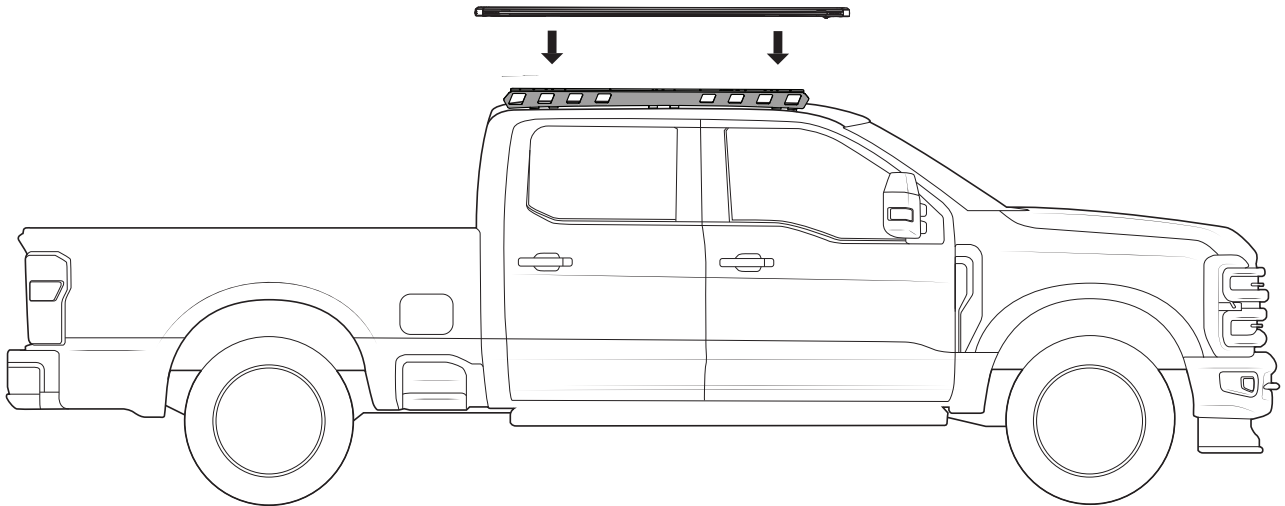
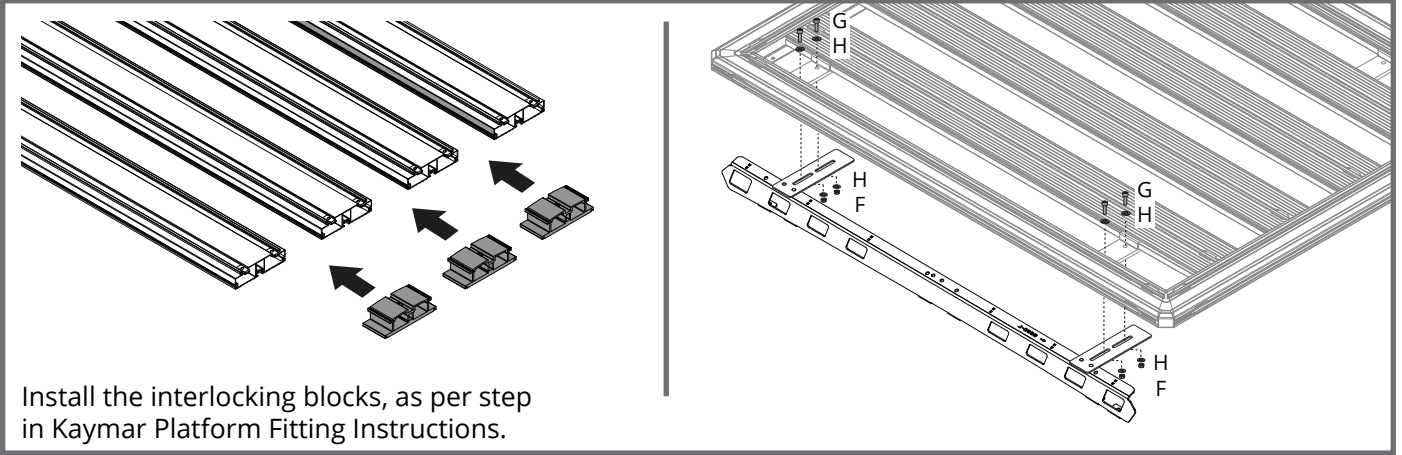

Note:

Wiring can be run and secured on the underside of the Ridge Mount rail as shown.

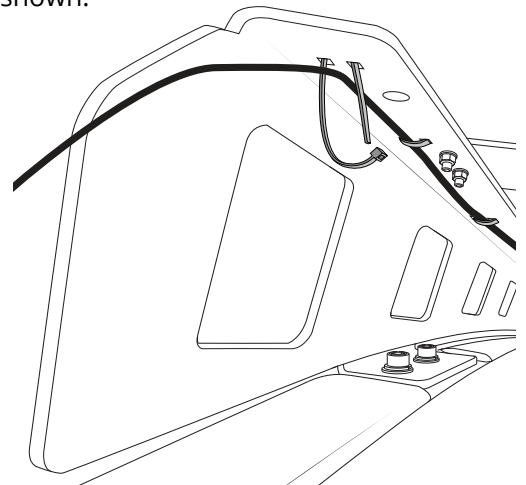
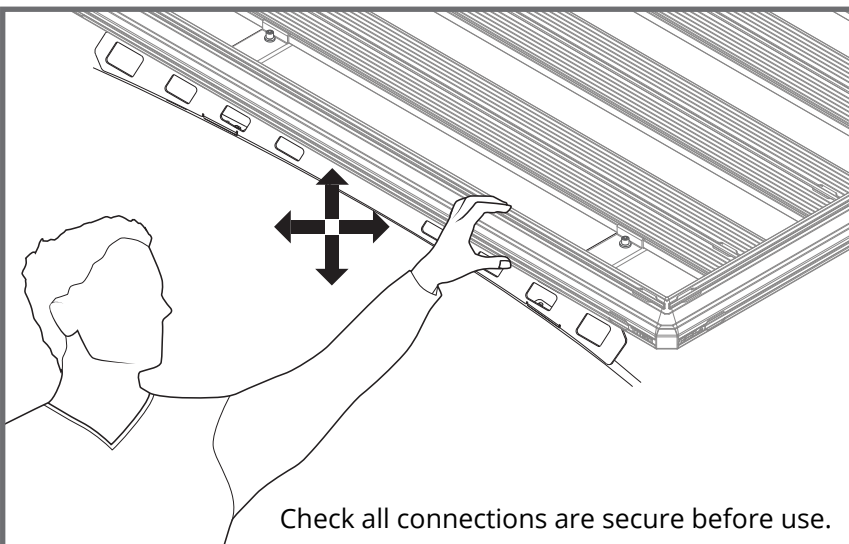

IMPORTANT - READ BEFORE USE

Please ensure the system is fitted in accordance with the fitting instructions.
It is important that you observe all outlined below.

**LOAD RECOMMENDATIONS**

- Routinely and regularly check the proper functioning of the system. Check all fixtures at regular intervals.
- Do not use an automatic carwash with system installed.
- Maximum load capacity of the system is 661lbs/300kg under static conditions.
- Maximum load capacity of the system is 220lbs/100kg under dynamic including off-road conditions.
- Do not exceed vehicle manufacturers recommended load rating if it is lower than the maximum load capacity specified in this document (i.e., 220lbs/100kg).
- Ensure any load carried is evenly distributed.
- Actual load on vehicle Roof (Refer to owner's manual) = Weight of Roof rack system / Ridge Mount + Weight of platform + Weight of cargo.
- Actual load on rack system (Refer to product instructions) = platform weight + cargo.

WARRANTY INFORMATION

For full Warranty details refer to Kaymar website.

Kaymar.com.au

NOTE

All content subject to APG copyright.