



APPLICATION AND MOUNTING INSTRUCTIONS

DuraLED® Combi-SR Rear Combination Lamp
STOP / REAR POSITION / INDICATOR / REVERSE LAMP WITH REFLECTOR
Multivolt (Suitable for 12 and 24 volt systems)

Features Include:

- | | |
|---|--|
| DuraLED® Combi = Fully sealed against salt-water submersion | DuraLED® Combi = Reverse polarity protected |
| DuraLED® Combi = Stop, Rear Position, Indicator and Reverse functions in a single lamp | DuraLED® Combi = Low power consumption |
| DuraLED® Combi = Vibration and shock resistant | DuraLED® Combi = Manufactured from the latest "high tech" materials with enhanced impact and chemical tolerance |
| DuraLED® Combi = Ultra long service life | DuraLED® Combi = Enhanced transient spike protection |
| DuraLED® Combi = Ultra fast response time | |

Lens Marking and ADR 13/00 Installation Requirements

This lamp identified by lens marking 0710 and the logo, was manufactured to comply with:

- ADR 1/00 Reversing Lamps
- ADR 6/00 Category 2a Rear Direction Indicator Lamps
- ADR 47/00 Reflex Reflector
- ADR 49/00 Rear Position (Side) / Stop Lamps
- A tolerance of +/-3° applies on all mounting details.
- Lamp mounting surface must be vertical to the ground, and at right angles to the longitudinal axis of the vehicle.
- Lamp must be visible from 45° inboard and 80° outboard, as well as from 15° above and below the horizontal axis.
- Lamp is approved to be mounted horizontally only

Please refer to ADR 13/00 for more details.

Side View



Rear View

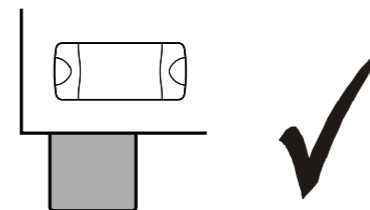
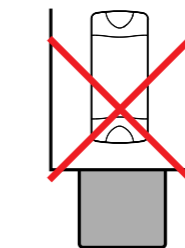

Top View

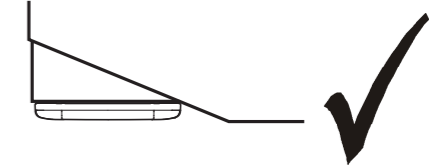
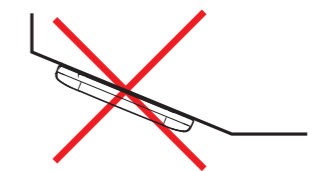

LENS IDENTIFICATION NUMBER: 0710

CATALOGUE NUMBER	ENGINEERING NUMBER	CRN NUMBER	COMPLIANCE NUMBER	ADR 51/00 GLOBE	ADR APPLICABLE
2380	015 074-00	50199 50202 50201 50204 50198 50200 50203	DURA-CRN-01A DURA2CRN-01A DURA-CRN-06A DURA2CRN-06A DURA-CRN-47A DURA-CRN-49A DURA2CRN-49A	N/A LED	ADR 1/00 ADR 6/00 2a ADR 47/00 ADR 49/00
AMENDMENTS				ADR COMPLIANCE VERIFIED Steve Jenkins & Associates Pty Ltd	ISSUE DATE: 09/05/2019
					460 965-11

HELLA-New Zealand Limited, Auckland, New Zealand



Lamp Mounting Instruction

Screw Cap Removal

Carefully insert a small flat blade screwdriver between the cap and the lens and pull towards the lens, the cap will clip off. To install the cap push in by hand until the top is flush with the lens.

Surface Mounting

- Drill two holes up to 6.5mm Ø at 193mm centres. 6mm Ø screws or bolts are recommended to mount the lamp using the mounting bushes provided.
- Lamp should be mounted on a flat surface.
- If passing the cable through a hole, ensure there are no sharp edges to cut or chafe the cable. Alternatively, cable can be routed through the end of the base.
- Connect lamp as per chart below.
- Try to keep the cable as long as possible, preferably join the cable inside a sealed cable junction box.
- Clip the screw caps on securely until flush with the lamp surface.

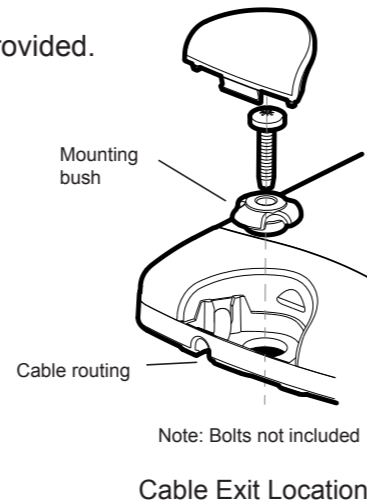

General Dimensions (in millimetres)

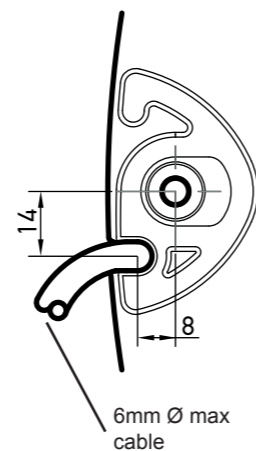
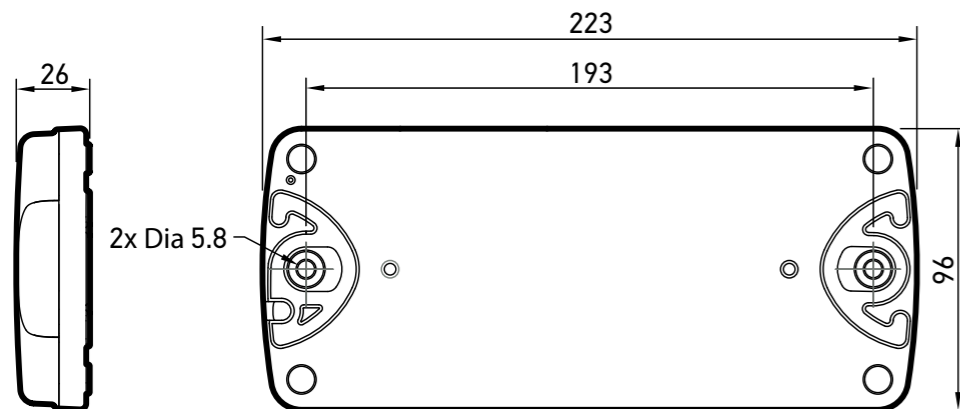

Wiring Colour Coding

Lamp is polarity conscious. The reversal of the polarity will not damage this product but will inhibit its function. HELLA recommends wire connections be soldered, and heat shrink tubing applied to seal the joint.

Colour	Connect to	Power Consumption
White	Earth (-)	-
Red	Stop (+)	5 watts
Brown	Rear Position (+)	1.5 watts
Green	Indicator (+)	6 watts
Pink	Reverse (+)	2 watts

NB: Lamp must be protected by a fuse rated at 5 amperes maximum.

Important Notes for Installer and Vehicle Owner



Introduction

Multivolt LED signal and marker lamps offer many advantages over conventional bulb lamps. Significantly reduced power consumption, ultra long life and high tolerance to shock and vibration make LED lamps the ideal choice for the commercial transport industry, where the cost of ownership versus the initial purchase price of the product is well understood.

Compatibility to existing electrical systems

It is important for the installer to ascertain the compatibility of the low power consumption LED lamps with the electrical and/or electronic systems of the complete vehicle, including trailers. In most cases the reduced power consumption is beneficial by imposing less demands on the entire electrical system. For certain functions some electrical systems rely on a set power consumption for monitoring whether, for example, a trailer is connected. Operation of this lamp using alternating current or modulated direct voltage will cause premature light failure. HELLA recommends connecting ADR or ECE certified Multivolt LED signal and marker lamps to a continuous (unmodulated) 12V or 24V power supply to ensure safe light operation.

Electromagnetic Compatibility (EMC)

This Multivolt LED lamp is an electronic device. The electrical circuits contain components that suppress possible interference, both emission as well as susceptibility, to the limits prescribed in UNECE Vehicle Regulation No. 10. To avoid false signals or interference, it is standard practice that sensitive instrumentation such as ABS and Tachometers etc. are provided with direct earths.

Protection against damage due to voltage spikes

This Multivolt LED lamp is protected against damage from positive voltage spikes caused by events such as load dump conditions specified in ISO 16750-2 and contains a Transient Voltage Suppressor (TVS) designed to withstand a pulse of up to 5000 Watts. The lamp is protected against reverse polarity connection and negative voltage spikes of up to 1000 volts.

Electric Welding

Electric Welding may damage the LED lamps. For LED lamps, HELLA recommends the negative connection to be wired isolated from the vehicle chassis. If the lamp uses the chassis as the earth return it is recommended that this earth return is disconnected during electric welding.

Warranty Statement

Congratulations! The product you have selected comes from HELLA - one of the world's leading manufacturers of lighting products. The product comes with a Lifetime Warranty covering faults in materials, components or workmanship.

In the unlikely event that you should experience a confirmed warranty related problem with your purchase, HELLA will, at its discretion, either repair or replace the product or refund the purchase price.

Warranty services may be obtained by returning the product within the warranty period to the HELLA Dealer where the product was originally purchased. This warranty is in addition to and does not preclude any other rights or remedies available to the consumer under any local legislation related to the provision of goods or services.

Our goods come with guarantees that cannot be excluded under the Australian Consumer Law. You are entitled to a replacement or refund for a major failure and for compensation for any other reasonably foreseeable loss or damage. You are also entitled to have the goods repaired or replaced if the goods fail to be of acceptable quality and the failure does not amount to a major failure.

Lifetime means the economic life of the vehicle these products were first installed on.

This warranty does not cover:

- 1.) Claim/s as a result of normal wear and tear or of any modifications, alterations non-compliance of assembly, service and operating instructions and/or any unfit or improper use.
- 2.) Any expenses incurred in the process of making the claim.

Note: For lamps sold in Australia, warranty services are provided by HELLA Australia Pty. Ltd., 4 Hargrave Place, Mentone, Victoria 3194 Australia. Customer Service 1800 061 729 email: custservice@hella.com
https://www.hella.com/hella-au/assets/media_global/IAM_Statement_of_Warranty.pdf

For general comments about HELLA's products please contact us on E-mail at: techfeedback@hella.co.nz