

Instructions

Rear Leaf Spring Bushings

Application: Toyota Landcruiser – 76, 78 and 79 Series

N.B: This instruction sheet should be used in conjunction with the workshop manual and proper safety procedures followed.



1. Raise rear of vehicle evenly until wheels are off the ground - safely support.
2. Using a jack, support the Diff housing.
3. Un-bolt shackle and/or Eye nuts and bolts

Note - only replace 1 side at a time.

4. Remove/press out bushings. Make sure Eyes are clean from any dirt or debris.

Note - kits are supplied with optional steel tubes and steel washers.

Front Eye and Rear Eye -

Confirm eye bolt/shackle OD.
18mm OD - discard steel tubes
Under 18mm OD - use steel tubes.

Confirm bushing flange thickness required.
8mm - discard steel washers.
10mm - use steel washers.

Rear Shackle -

Confirm bushing flange thickness required.
6.5mm - discard steel washers
8.5mm - use steel washers

5. Lubricate bushing ID and flange faces. Tighten bolts to manufacturers specs.

6. Road test and re-check bolts after 100kms travelled.

Place steel washers under flange if required.

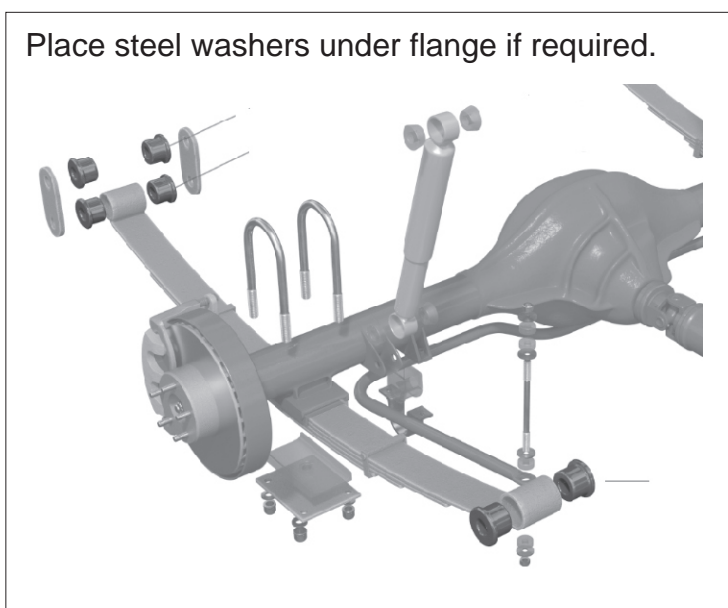

N.B: It is recommended that a licenced workshop or tradesperson carry out the above procedure and that workshop manual and relevant safety procedures are followed in addition to the above.