

Instructions

Leading Arm To Chassis Bushings

N.B: This instruction sheet should be used in conjunction with the workshop manual and proper safety procedures followed.

Application: Landrover Discovery

1. Raise front of vehicle evenly and safely support.

Note - It is recommended only one arm be removed and serviced at a time.

2. You may use additional Jack Stands under the differential when at full droop.

3. Remove arm from vehicle and proceed to press out old bushing.

4. Once removed, be sure Leading arm Eye is clean from any dirt or rust.

5. Using a Press and a pressing flat face, push supplied bushing into arm - soapy water may help.

6. Grease bushing ID and face with supplied grease only.

Note - The 2x flat washers supplied are to be installed on the inside of the Leading arm only. Extra grease can help hold washer in place during install.

7. Bolt arm back on vehicle - tighten bolts to manufacturers specifications.

8. A wheel alignment is recommended post install.

9. Re-check all bolts after 100kms travelled.

Add supplied washer to inside of Leading arm only - grease both sides of washer.

Wipe off excess grease.

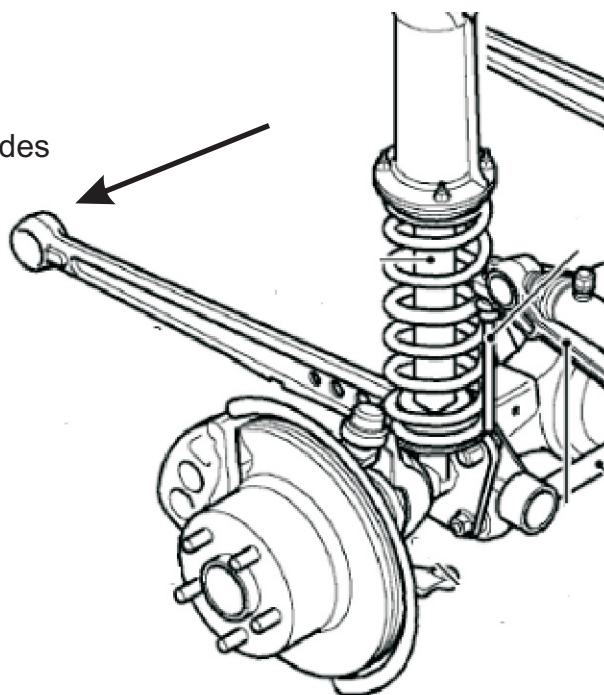

N.B: It is recommended that a licenced workshop or tradesperson carry out the above procedure and that workshop manual and relevant safety procedures are followed in addition to the above.