

# Fitting Instructions #4128XIS

## Nissan Patrol Y62

### Rear Control Arm Upper & Lower-Inner Bush Kit (Offset)

**Note:** Polyurethane bushings must be fitted to both sides of the vehicle.

- Wheel-align the vehicle before the job is started and note settings;
- With the vehicle on jack stands, remove the control arms;
- Remove the original bushes including the steel shell;
- Apply the grease supplied to the control arm housing and the outside surface of the bush;
- Using the appropriate pressing tools, support the control arm and press the new '4128' bushes in the arm housing. Note the orientation of the bush to be pressed in the control arm housing. Refer to: Figure 03 for the Rear Upper Control Arm bush kit installation; **Figure 04** for the Rear Lower Control Arm bush kit installation.

**Note:** use a flat plate to cover all surface of the end of the bush to press the shell in the housing.

- Apply the grease supplied to the bore of the bush and the outside surface of the steel crush tubes, then push the crush tubes in the bush. Note: Tubes Must be pressed in correct orientation for appropriate alignment correction. Refer to **Figure 01 & 02** for orientation of the crush tube in the bush.
- Refit the control arms to the car and tighten the bolts to manufacture's torque settings;
- Re-assemble the rest of the car and carry out a wheel alignment.

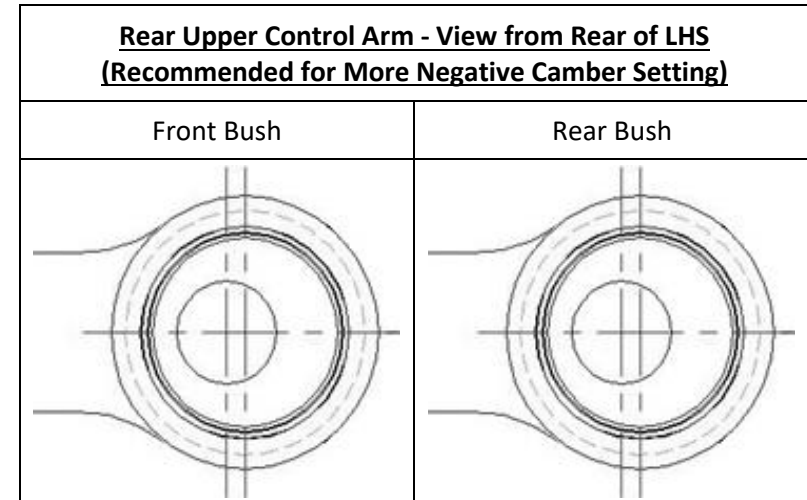

Figure 01 - LHS Rear Upper Control Arm, Rear View

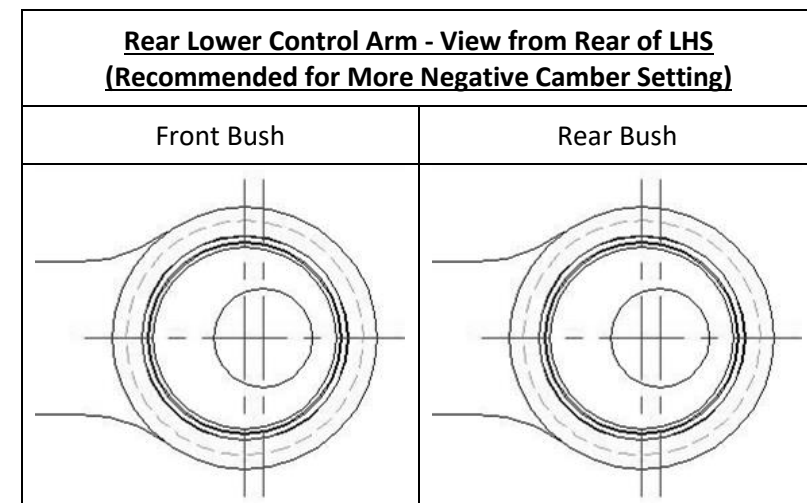

Figure 02 - LHS Rear Lower Control Arm, Rear View

# Fitting Instructions #4128XIS

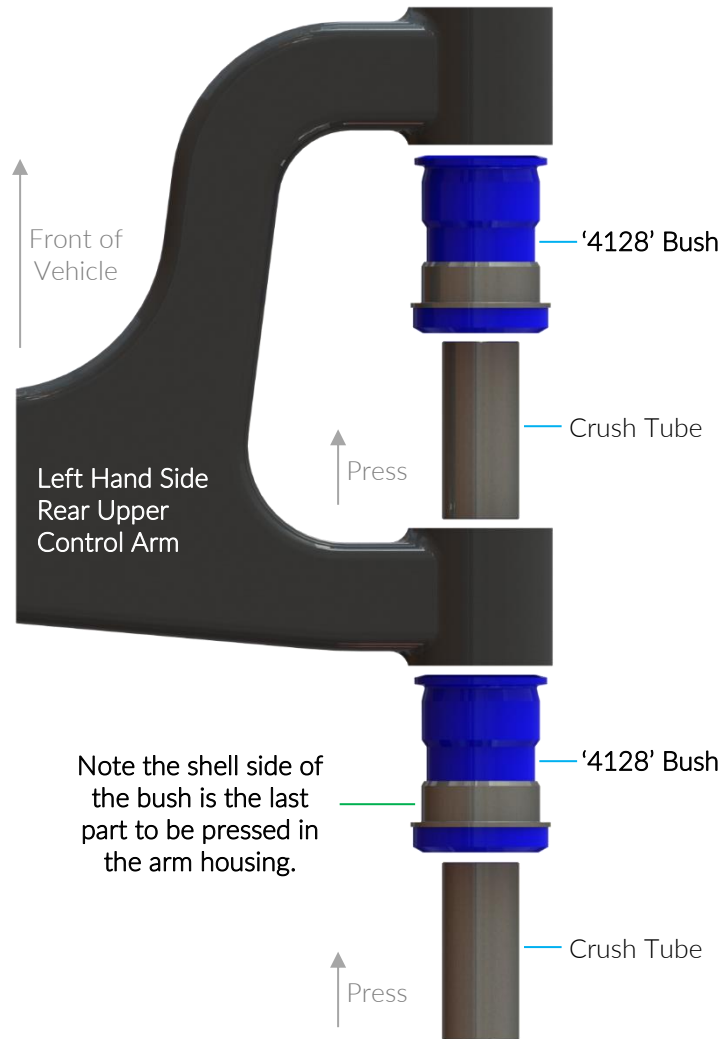

Figure 03 - LHS Rear Upper Control Arm Bushing, Top View

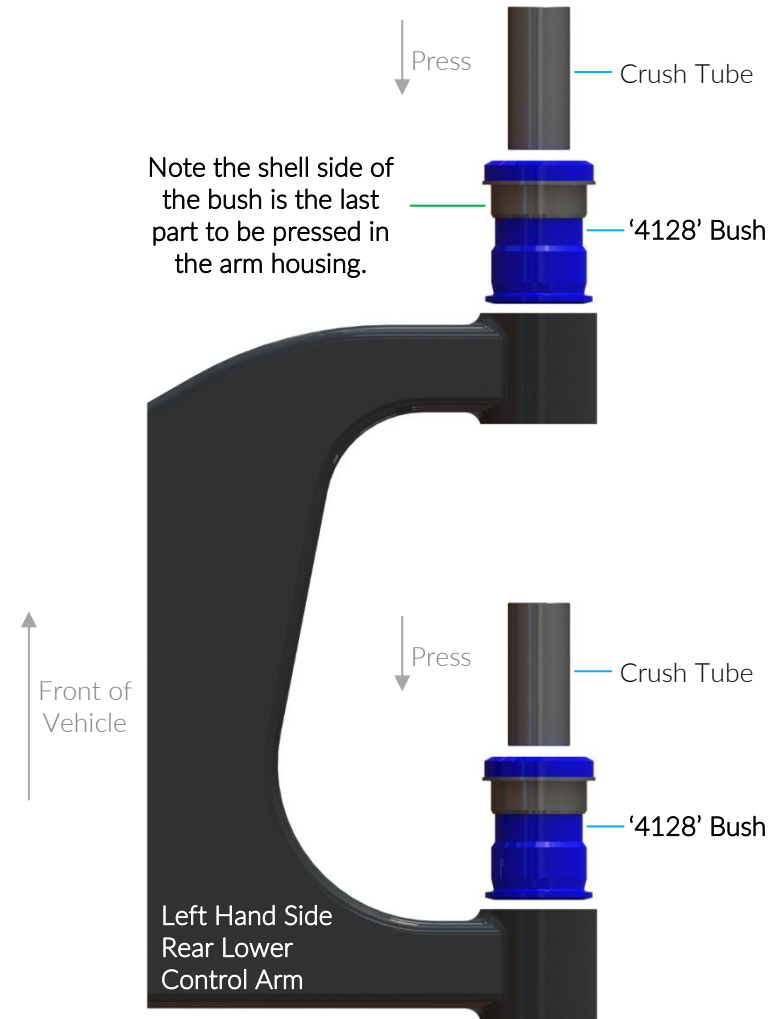

Figure 04 - LHS Rear Lower Control Arm Bushing, Top View