

Install Guide Front Radius Arm - With Caster Increase



Page 1 of 2

Application - Holden Commodore VE
- 2006-2013

(Always refer current catalogue listing)

Contents - 1 (or 2) replacement control arms
- with polyurethane bushing
- offset caster plates
- flange nuts

- Raise vehicle evenly and safely support with a hoist or stands.

Never rely on a Jack only

- Proceed to remove front wheels.

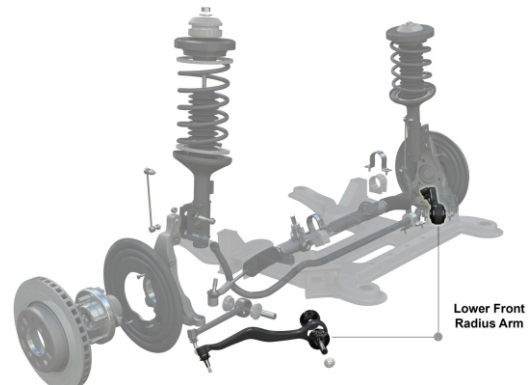

- Loosen the ball joint nut. Leave the nut on the thread as you break the hub taper with a hammer.
- Loosen the front arm bushing bolt. Then remove.

Note - the nut is welded to the inner plate.
Refer below image:

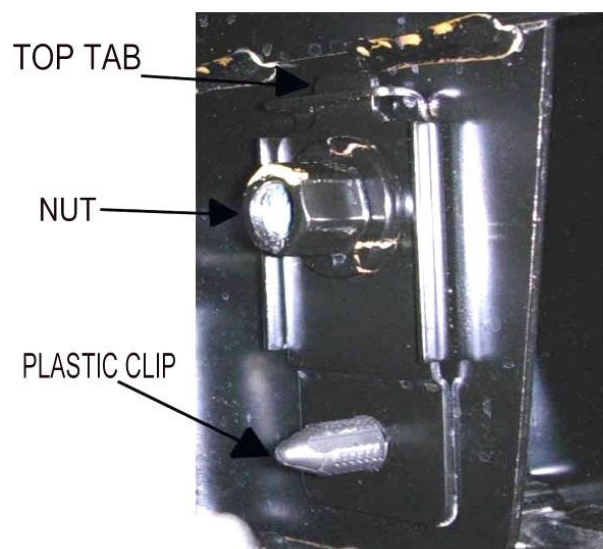

- Prepare the new control arm for install.
- Note the supplier grease. Confirm the control arm bushing internal diameter is greased. Also, apply a small amount of grease to the bushing side face.

Refer page 2 -

Note: These components must be fitted by a qualified person only, as per the manufacturers service manual. Also, that all relevant safety procedures are followed in addition to above.

Install Guide Front Radius Arm - With Caster Increase



Page 2 of 2

Important - these control arms are supplied with offset caster plates. These plates increase caster slightly, approx. 0.5-1.0 degree.

Refer the vehicle wheel alignment data for appropriate installation.

Alternatively, If 1 control arm only is to be installed, SuperPro suggest to discard the offset shim. If it is determined there us a lack of caster on the L or R side, the supplied shim will improve.

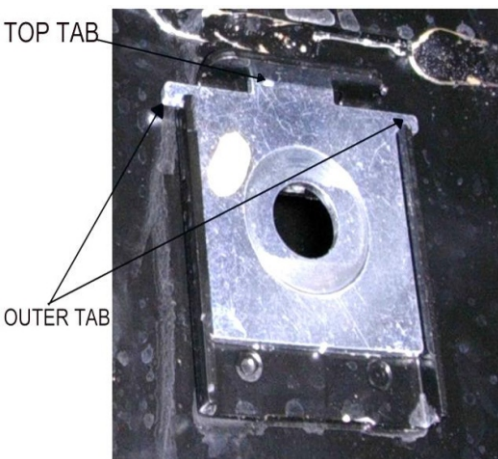
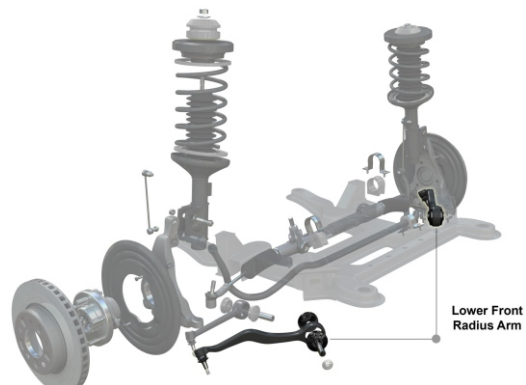

TOP TAB

OUTER TAB

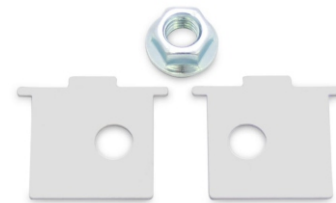

- If both L and R arms are to be replaced, SuperPro recommend fitting the off-set shims to both sides.
- Remove the factory 'on-centre' plates. The outer one will need to be swung approx 60 degrees. **Refer LH image.** The inner one will require the removal of a plastic clip. **Refer image on page 1.**

- Pop the new off-set plates in sub-frame. For caster increase, check the hole is towards the front of car. Also be sure the plate is properly in position with both tabs sitting in each slot.
- Re-fit original bolt **with supplied flange** nut and tighten.

Note - a wheel alignment will be required.

- Re-check all bolts after 500-1000kms



Front of vehicle

For caster increase, place hole towards front of vehicle

Note: These components must be fitted by a qualified person only, as per the manufacturers service manual. Also, that all relevant safety procedures are followed in addition to above.