

IMPORTANT - READ BEFORE USE

Please ensure that the system is fitted in accordance with the fitting instructions. It is important that you observe all outlined below.



KIT COMPONENTS

Your APEX Kit should contain:

1. 2 x Cross Bars and Buffer Strips
2. 4 x End Supports Chassis
3. 4 x Covers and Locks
4. 1 x Small Parts and Hardware Kit

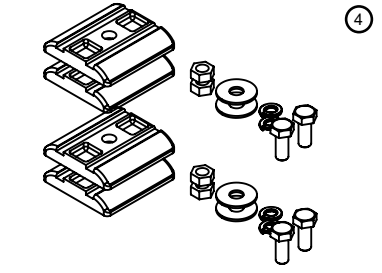
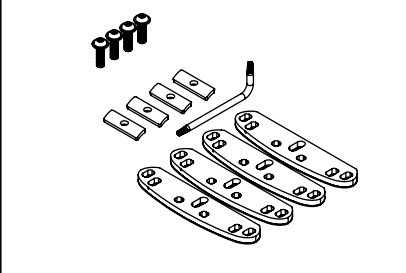
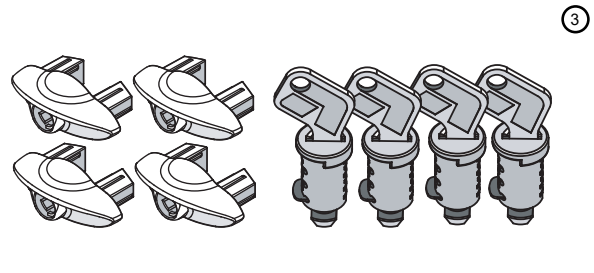
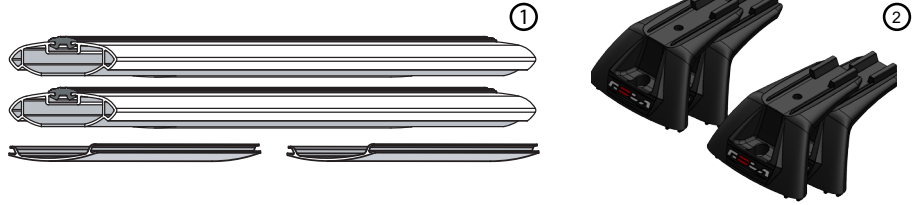

You will require the following tools:

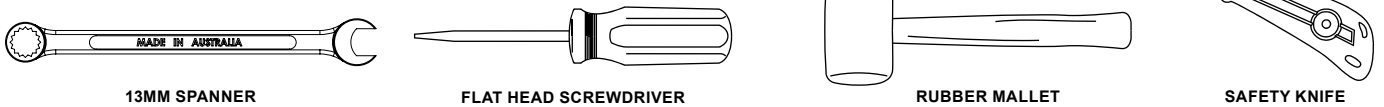

13MM SPANNER

FLAT HEAD SCREWDRIVER

RUBBER Mallet

SAFETY KNIFE

FITTING INSTRUCTIONS

ASSEMBLY OF CROSS BARS

Please check your Roof Rack box to ensure you have received all components. Read these instructions thoroughly before commencing installation. (Please contact your dealer if your KIT is incomplete)

1. Cut to length and apply the Foam Strip to the bottom of the Brass Nut. Insert the Brass Nut through the end of the tub channel from where the tub meets the cab of the vehicle (Fig. 1). The Foam Strip is used to lift up the Brass Nut and help engage the Security Bolt.
2. Attach the End Support on two Adaptor Plates on the tub shutter channel directly above the Brass Nut and insert the Security Bolt and Washer (Fig. 2). Your End Support should look like Figure 3. Do not fully tighten yet.
3. Fit all End Supports and line opposing sides up with each other to the preferred distance.

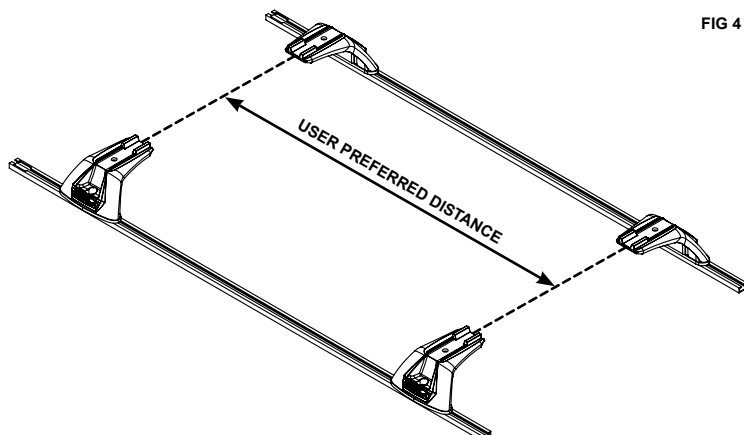
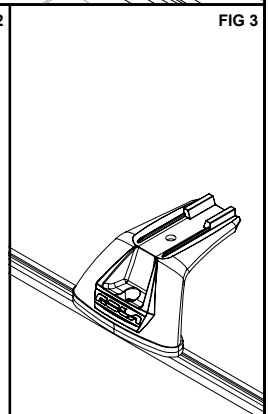
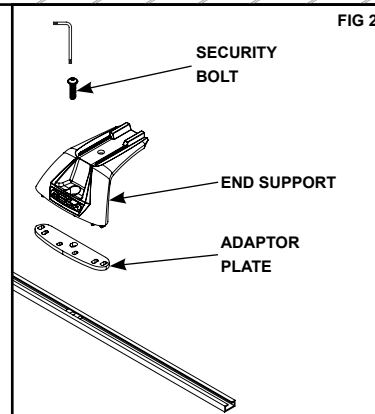
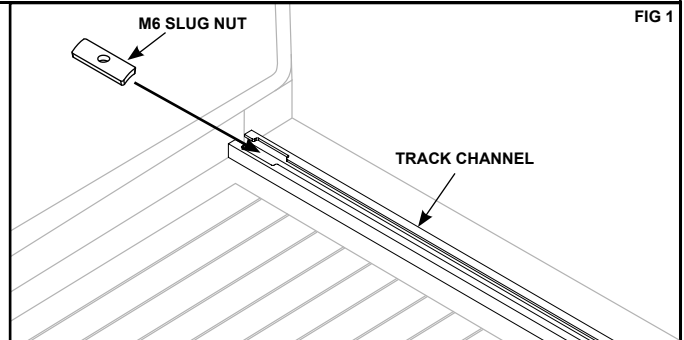

FITTING OF CROSS BARS TO VEHICLE

- Place the Cross Bar onto the End Supports ensuring that the End Supports are located into the cutouts on the underside of the Cross Bar. Check that the Cross Bar is over hanging equally on either side (Fig. 5).
- Insert the M8 Nut into the cavity on the Commercial Slug. Insert the Commercial Slug into the Cross Bar, and align it so that the M8 Nut in the Commercial Slug and the hole at the bottom of the End Support line up (Fig. 6).
- Secure the Cross Bar to the End Support by screwing the Hex Bolt through the hole in the End Support and up into the Nut that is located in the cavity of the Commercial Slug (Fig. 7).
- Refer to Undercover Strip Instructions on Page 3 to fit Undercover Strips.
- Using a 13mm Spanner, full tighten the Hex Bolt on the underside of the End Support. Using the Security Key, tighten the Security Bolts to approximately 7Nm of torque or a firm hand-tightness.
- Ensure all fasteners are securely tightened.

Ensure that both Cross Bars are parallel to each other. Ensure that the bolts are tightened and that the Cross Bars are well secured. Perform a quick check by tugging on the Cross Bars back and forth.

INSERTING END CAPS

- Pull back the Buffer Strip to allow access to the end of the Cross Bar. Insert End Cap into the Cross Bar by locating the two 'feet' of the End Cap into the void inside the Cross Bar (Fig. 8).
- Push through until the End Cap edge comes to rest against the edge of the Cross Bar. This is important as the Locking Actuator inside the End Cap has to locate within the Locking slot on the end of the Cross Bar (Fig. 9).

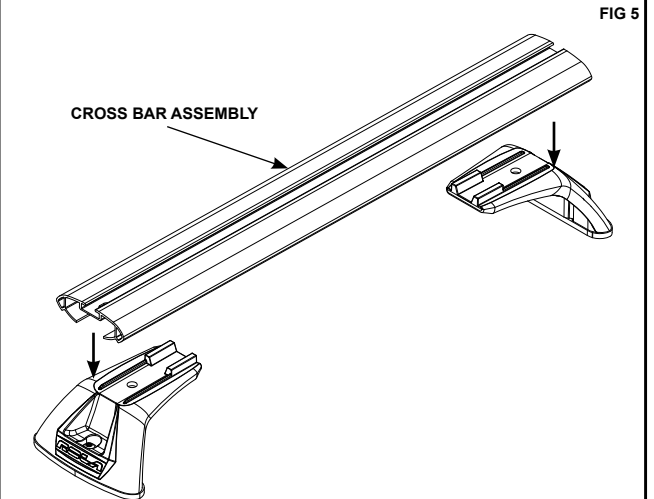
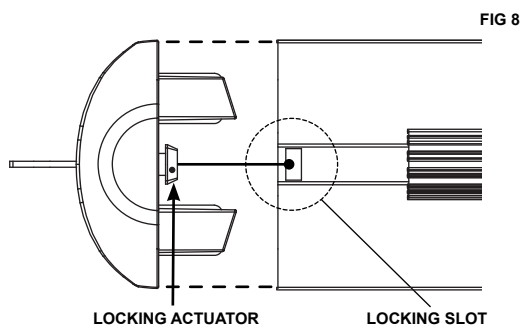

NOTE: ROOF RACKS SHORTENED FOR ILLUSTRATIVE PURPOSES ONLY

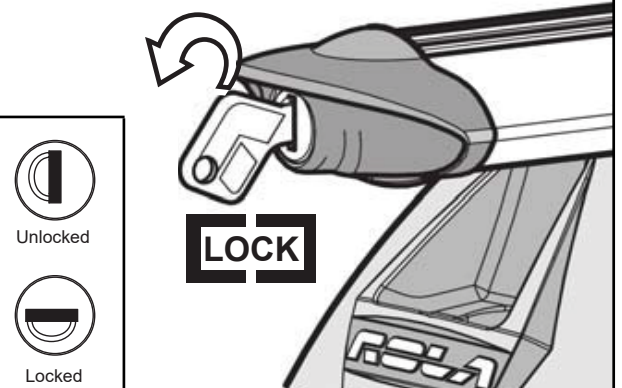
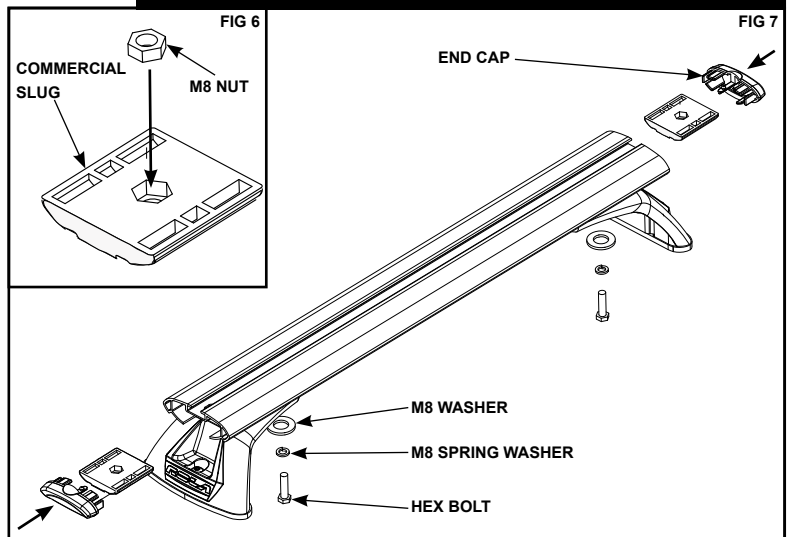
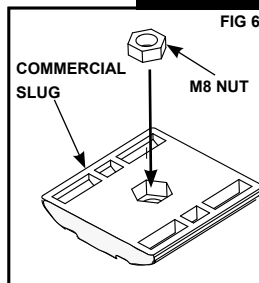

GENERAL USAGE INFORMATION



REGULARLY CHECK THE TIGHTNESS OF LOCKING STRAPS.

Loads should be evenly distributed and secured. A number of accessories for carrying special loads are available. Only use **NON-STRETCH** tie down straps.

Any weight carried on the vehicle will adversely affect its handling particularly in cornering or in a cross wind and the vehicle should therefore be driven with increased caution. Refer to the attached load rating sheet for carrying capacity.

For full warranty information, visit our website: www.rola.com.au.

FITTING UNDERCOVER STRIPS

Mounting the Undercover Strip is important in preventing water/dirt ingress and vital to minimising wind noise during travel.

The Undercover Strip applies to both the Commercial Series and the Sports Series Roof Racks. See the diagrams on the right showing the possible configurations where the Undercover Strip applies.

NOTE: Ensure the Roof Rack Assembly is assembled as per the Fitment-specific Fitting Instruction before proceeding to Step 1.

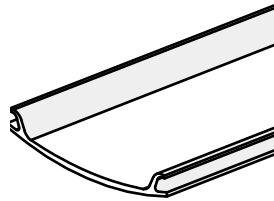

SPORTS SERIES CONFIGURATIONS

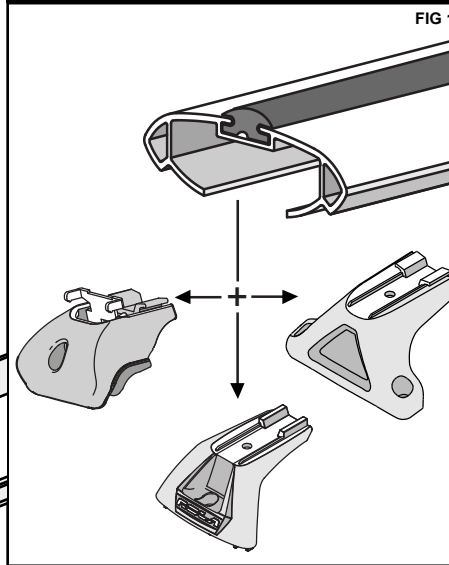

COMMERCIAL SERIES CONFIGURATIONS

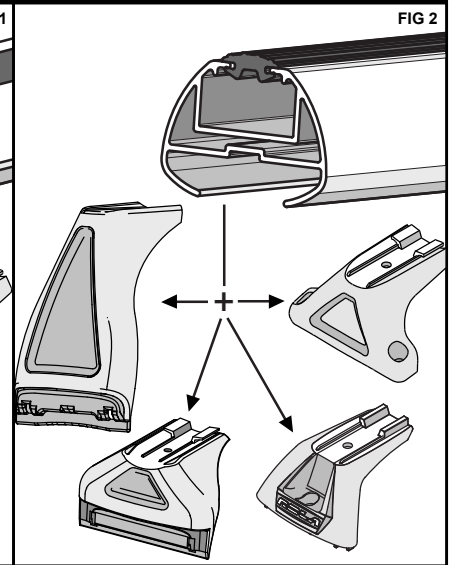

INSTRUCTION FOR SPORTS SERIES

1. With the Cross Bar loosely positioned symmetrically between the End Supports, mark up the location of the End Support against the gaps requiring coverage, using a lead pencil. Using a rule, measure the distances for (X) and (Y) as shown in Figure 3.
2. With the Cross Bars removed, line up the Undercover strip with the cut-out on the Cross Bar. Ensuring the 'Strip edge' and the 'Cross Bar cut-out edge' are aligned, mark the Undercover Strip with a line that corresponds to the line you marked on the Cross Bar, as instructed in Step 1 and Figure 4. Using a Rule and Blade, score a straight line and snap off this piece from the length of Undercover Strip. This becomes Cut Length (A).
3. Slide 'Cut Length (A)' into the gap until it butts up against the end edge of the gap in Figure 5. Do this for all four Cross Bar over-hang endings.
4. Next, insert all four End Supports into position. Using the remaining lengths of Undercover Strip, insert into the remaining gap of the Cross Bar until it touches the edge of the End Support. Trim the strip back to align with the edge of the Cross Bar for all four 'Cut Length (B)' strips as shown in Figure 6.

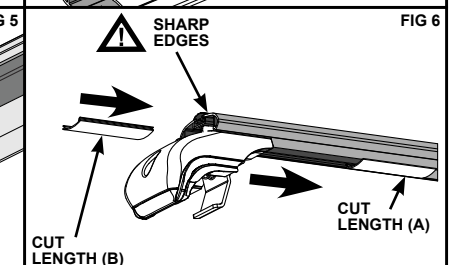
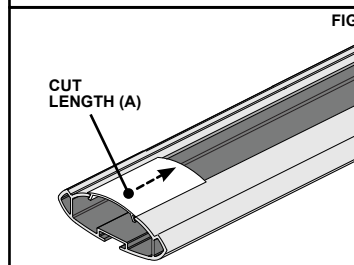
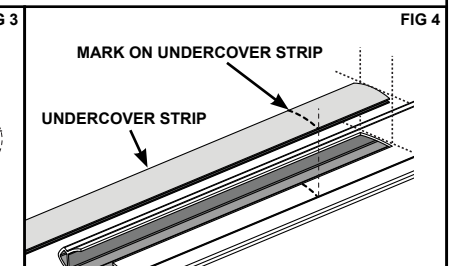
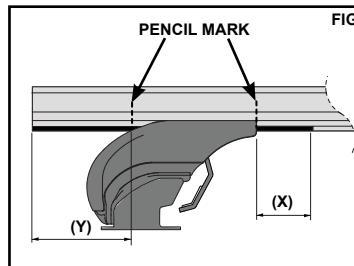

NOTE: YOUR END SUPPORT MAY LOOK DIFFERENT

INSTRUCTION FOR COMMERCIAL SERIES

5. Please refer to Step 1 & 2 of the Sports Series Instruction.
6. Insert Cut Length (A) into the gap between the End Supports ensuring there are no air gaps.
7. After locking down the End Supports in position, proceed to insert the remaining Undercover Strip into the Cross Bar, filling the remaining gap shown by dimension (Y) in Figure 7. Trim the Undercover Strips back to align with the edge of the Cross Bar for all four 'Cut Length (B)' strips.
8. Place one side of the Undercover Strip into the position as shown in Figure 8. Apply pressure along the edge of the Undercover Strip until the whole length is clipped securely into position.

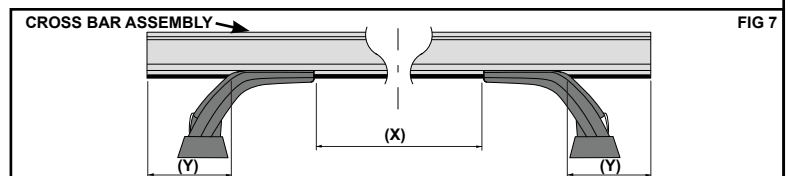

NOTE: YOUR END SUPPORT MAY LOOK DIFFERENT

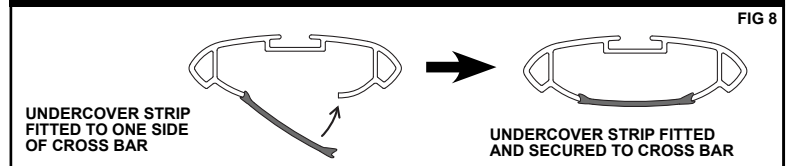

IMPORTANT - READ BEFORE USE

Please ensure that the system is fitted in accordance with the fitting instructions. It is important that you observe all outlined below.

**SAFE USAGE**

It is essential for the proper assembly, operation and use of the Roof Rack that the instructions and safety precautions supplied are strictly observed.

Loads should be evenly distributed across the Cross Bar length and width. Always ensure that the load has a low centre of gravity. Fasten the load securely against sliding and check regularly for correct positioning.

The Roof Rack and roof load must not project beyond the body of the carrying vehicle. The load must not extend beyond the sides of the Roof Bars. Long loads should be positioned centrally on the Roof Rack and securely fastened at the front and at the rear. Narrow and heavy loads should be carried as close to the End Supports as possible. It is your responsibility to comply with statutory requirements regarding the projection of your load.

- Ensure load is sufficiently secured with straps.
- Do not use elasticised or "occy" straps.
- Do not use damaged or frayed straps.
- Use separate tie downs for each Roof Rack.
- Check the security of your load and the tension of the bolts and fastenings of the Roof Rack before departing and at regular intervals during your journey.
- A specialised Roof Rack accessory should be used to carry or secure your load when available (eg, Bike Carrier, Water Craft Carrier).
- The maximum permissible load for your vehicle Roof Rack is the lower of the maximum load capacity specified in your vehicle operation manual, or specified as applying to the Roof Rack. Do not exceed the maximum specified load capacity.
- Maximum permissible load = weight of the Roof Rack + weight of accessories + weight of load (cargo).

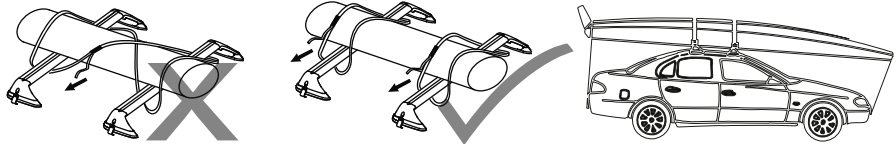

The mounted & loaded Roof Rack will affect your vehicle's handling characteristics, particularly relating to crosswind sensitivity, corners, bends and braking behaviour. Exercise care when driving and adjust for the change in vehicle handling and braking behaviour by always driving safely and at a speed appropriate to travel conditions and the load being carried.

Wind resistance is the number one cause of Roof Rack failures. Prior to securing a load, consider the surface area of the load to determine the suitability of carrying the load on the Roof Racks. Extra caution should be taken when travelling in high winds, at high speed, or when carrying loads with large surface areas (eg tables, bed bases and mattresses, sheets of wood).

Surfboards should be loaded on top of each other rather than side by side.

**MAINTENANCE**

The Roof Rack should be removed regularly to clean adjoining vehicle surfaces, attaching locations and the Roof Rack itself. It is your responsibility to ensure that the Roof Rack is adequately maintained.

You should routinely and regularly check the proper functioning of your Roof Racks, and tighten all screws, bolts, connections and straps. Immediately replace any worn or damaged components.

Remove Roof Rack before entering an automatic carwash.

When not used to carry load, the roof-rack should be removed. This will also increase fuel efficiency when not in use.

We recommend that you store the Roof Rack Security Key and Fitting Instructions in the glove compartment of your vehicle.