

Parts List:

Item	Description	Qty.	Part No.
1	Cross Bars (with Buffer Strip)	2 (1)	EX1450B
2	End Support	4 (2)	27-0752
3	Adaptor Plate	4 (2)	22-0936
4	M6 Brass Nut	4 (2)	
5	Security Key	1	22-0811
6	Fit Kit Hardware (Fig. 1b)	4 (2)	22-0349
7	Fitting instructions	1	
8	5 year warranty	1	

For the Single-Bar fittings, only the relevant Cross Bar and Bolts are included. The number shown in brackets denotes the quantity included in the Single-Bar fittings.

NOTE: Prior to Assembly

Prior to assembling, check that the kit contains all the parts you will need to fit the Roof Racks. Refer to the Parts List for guidance. Please read these fitting instructions prior to assembly.

Fig. 1a

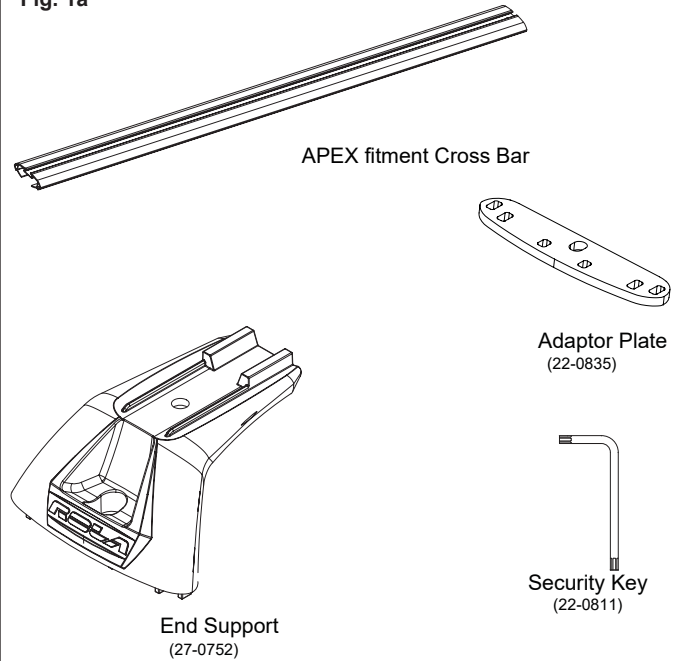

Please Note: You will require the following tools

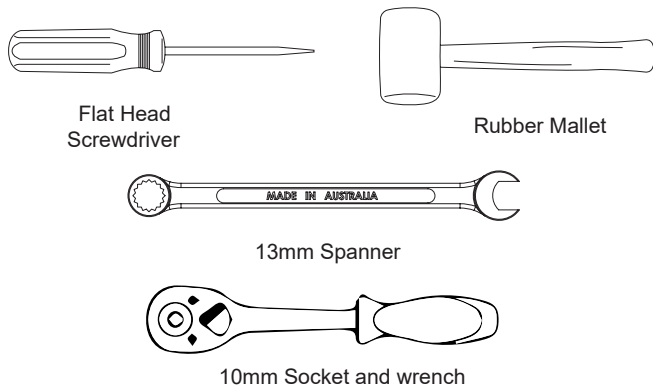
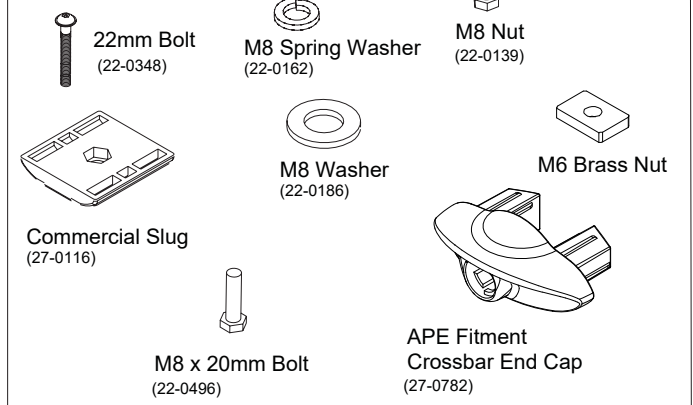

Fig. 1b Fit Kit - Hardware



STEP 1: Insert brass nuts

Insert M6 brass nut through the end of the tub shutter channel.

You may need to remove a rubber stopper from the channel to insert the brass nut.

Fig. 2

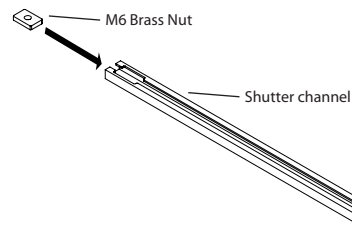

STEP 2: Fit end support

Locate the end support on the adaptor plate on the tub shutter channel directly above the M6 brass nut and insert the security bolt and washer (Fig. 3).

Do not fully tighten yet.

Fig. 3

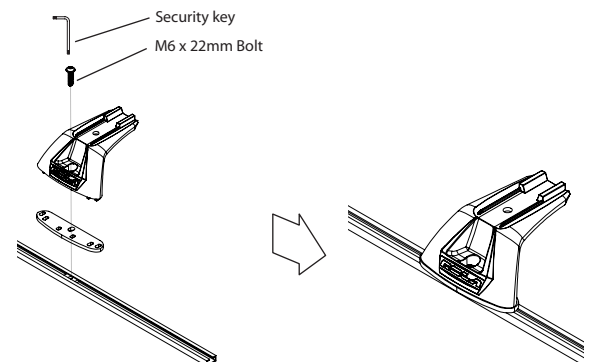

FAILURE TO FOLLOW THESE INSTRUCTIONS WILL VOID WARRANTY

STEP 3: Fit all end supports

Fit all end supports and line opposing sides up with each other

Fig. 4

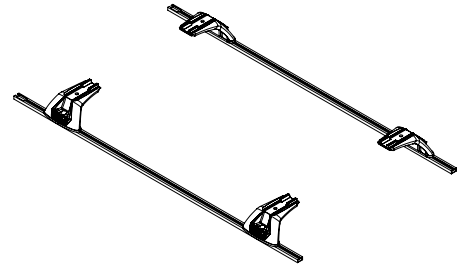

STEP 4: Fit Cross Bars

- Place the crossbar onto the end supports ensuring that the end supports are located into the cutouts on the underside of the crossbar. (Refer to Fig. 6a)
- Check that the cross tube has equally distanced overhang on either side from the end support.
- Insert the M8 nut into the cavity on the Commercial Slug. (Refer to Fig. 6b).
- Insert the Commercial Slug into the cross tube, and align it so that the M8 nut in the Commercial Slug and the hole at the bottom of the end support line up (Fig. 6b).
- Secure the cross tube to the end support by screwing the M8x20mm bolt through the hole in the end support and up into the nut that is located in the cavity of the Commercial Slug nut. (Refer to Fig. 6b).
- Using a 13mm Spanner, full tighten the 20mm bolt on the underside of the end support (Fig. 6b).
Using the Security Key, tighten the security bolts to approximately 7Nm of torque or a firm hand-tightness (Fig. 6b).
- Insert an end cap into both ends of the cross tube (Fig. 6b).

Fig. 5

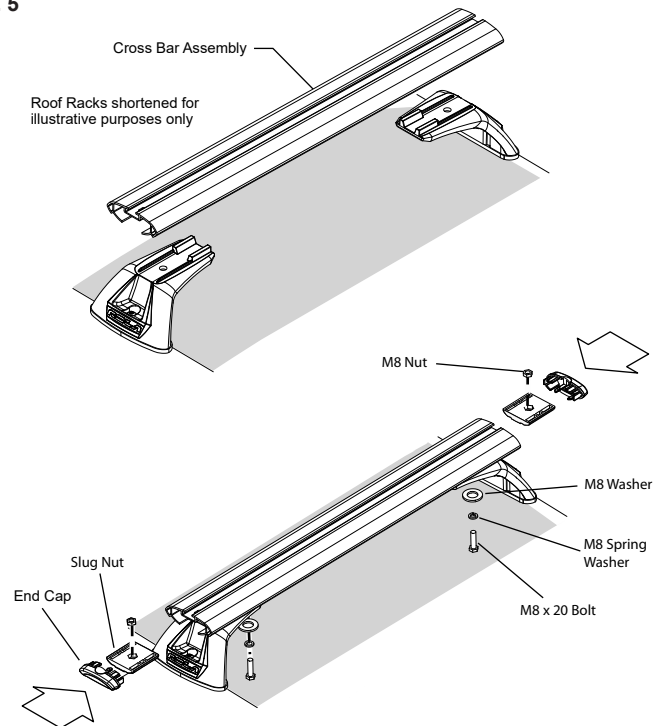

Ensure all fasteners are securely tightened.

STEP 4: Locking end caps (APEX only)

Pull back the buffer strip to allow access to the end of the cross-bar. Insert Endcap into the Cross-bar by locating the two 'feet' of the Endcap into the void inside the cross-bar. (Fig 8). Push through until End-cap edge comes to rest against the edge of the cross-bar. This is important as the Locking Actuator inside the Endcap has to locate within the end of the cross-bar. Locking slot on the end of the cross-bar.

Fig. 6

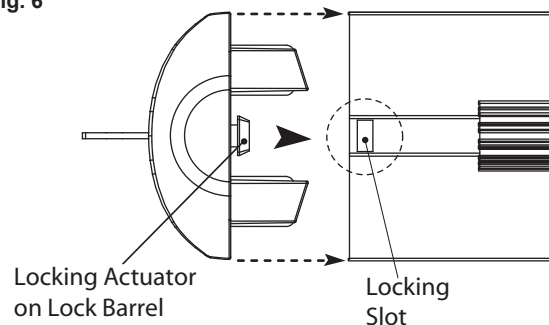

STEP 5: Using the Roof Racks

Refer to 'Care for your Racks' to maintain your Roof Racks.
 To load accessories into the Channel of the Cross Bars, remove the end cap from the end of the cross tube.
 Once the accessories have been loaded, re-insert the end cap back into the end of the cross tube.
 Note: You will have to remove or trim the Buffer Strip to mount accessories
 Intermittently check that all Screws and Bolts are sufficiently tightened whilst the Roof Racks are in use.

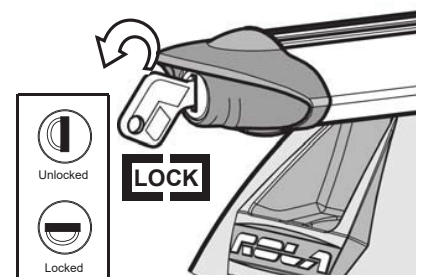

FAILURE TO FOLLOW THESE INSTRUCTIONS WILL VOID WARRANTY