

ROLA®

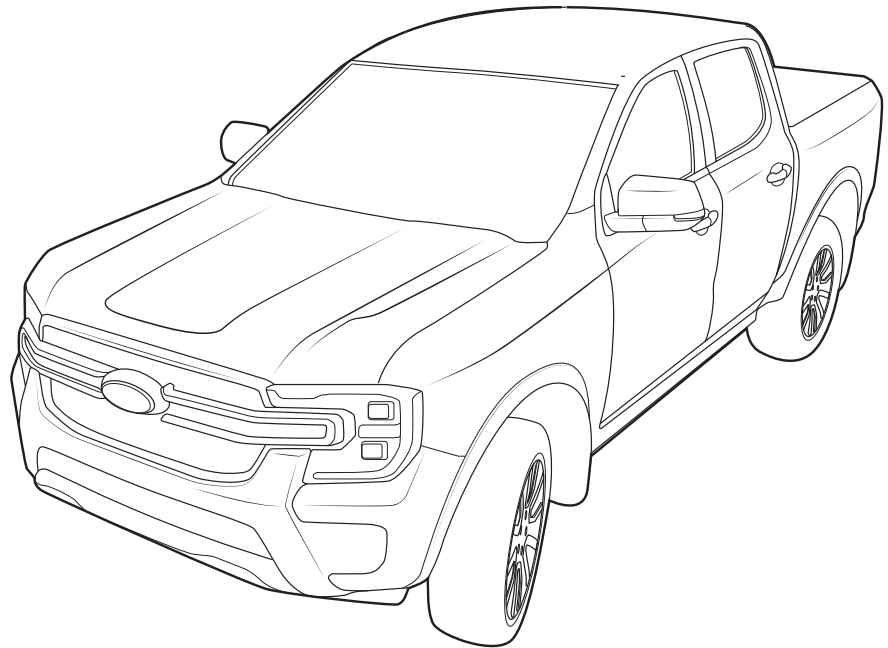
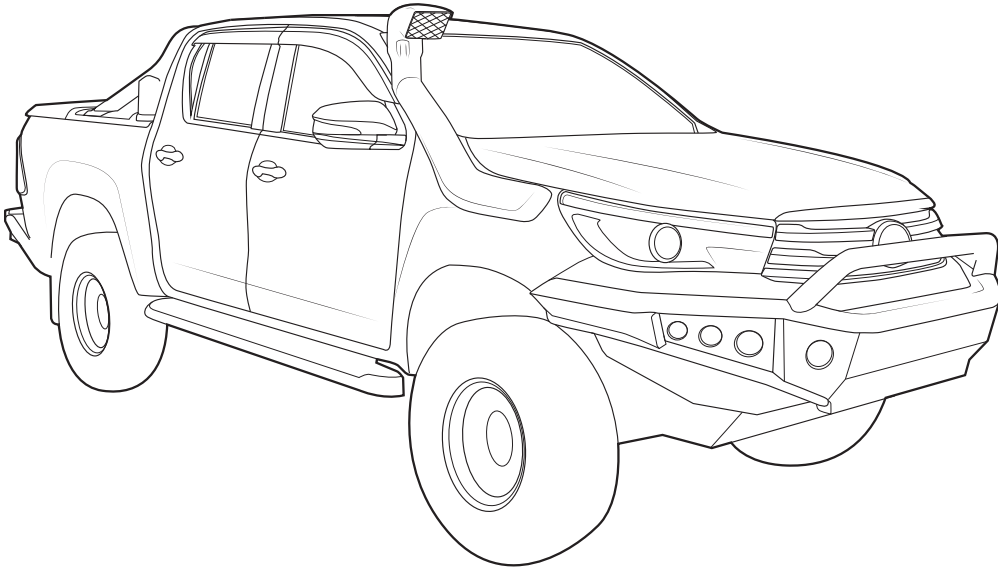

IMPORTANT: This kit is intended for fitment with R-BAR-TH-01 & R-BAR-FR-01 systems only.

Read this full instruction prior to commencing assembly and fitment of System.

CONTENT - CHECK ALL PARTS ARE CORRECT BEFORE PROCEEDING

25-0310

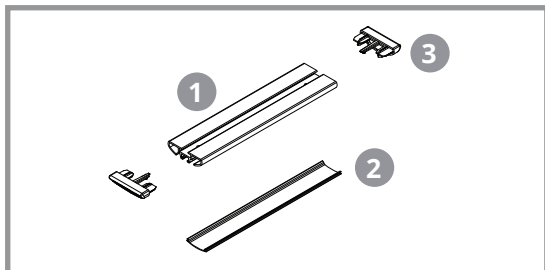

Item	Description	Qty
1	Titan Tray Self Support	4
2	Commercial Under Cover 450mm	2
3	Titan Tray Self Support End Cap	8

25-0368

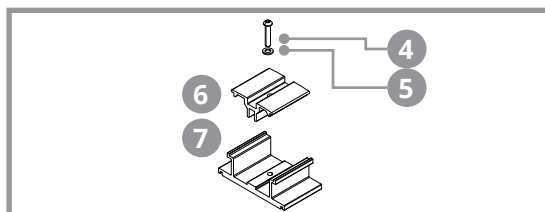

Item	Description	Qty
4	M6 x 30mm Button Head Screw	3
5	M6 Washer	3
6	Interlocking Block Cover	3
7	Interlocking Block	3

RWSLA28

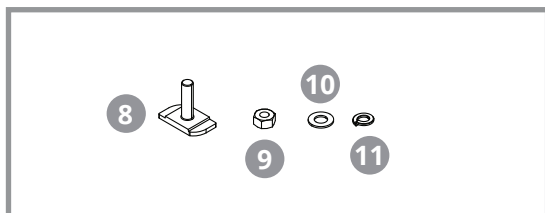

Item	Description	Qty
8	Drop and Turn Bolt	8
9	M8 Nut	8
10	M8 Washer	8
11	M8 Spring Washer	8

25-0632

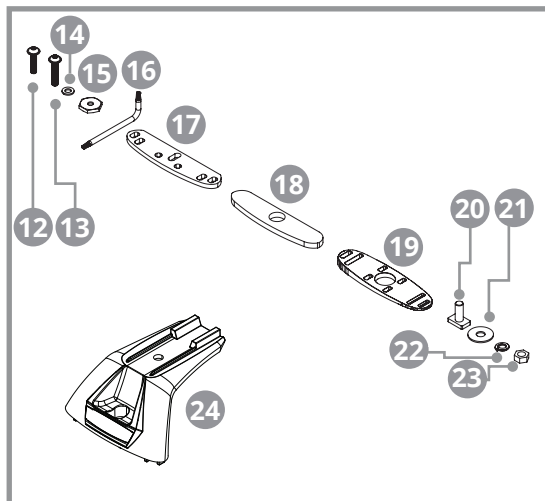

Item	Description	Qty
12	M6 x 25 Lobe Screw	2
13	M6 x 30 Lobe Screw	2
14	M6 Washer	4
15	M6 Brass Nut	4
16	TT-27 Allen Key	1
17	Steel Plate	4
18	Foam Pad	4
19	Level Adjuster	2
20	M8 T-Bolt	4
21	M8 Washer	4
22	M8 Spring Washer	4
23	M8 Hex Nut	4
24	End Supports	4

TOOLS REQUIRED

- 13mm socket wrench.
- Step ladder.
- Measuring tape.
- Knife/ cutters.

1

Refer to Titan Tray instructions.
Remove the end plank of the Tray.

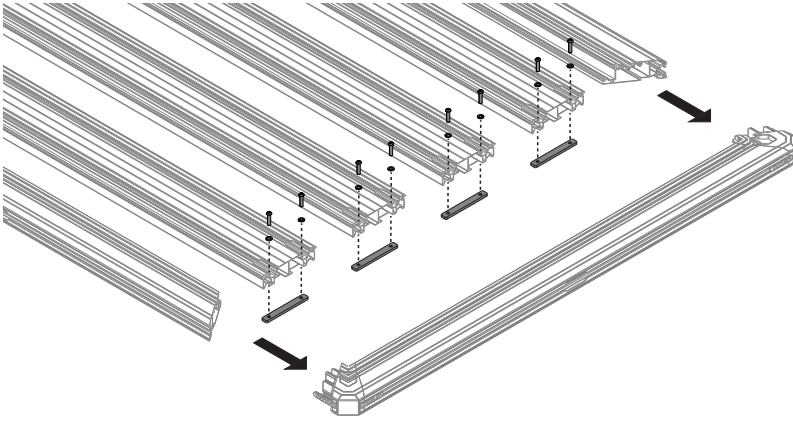

2

Insert the interlocking blocks to the central planks.

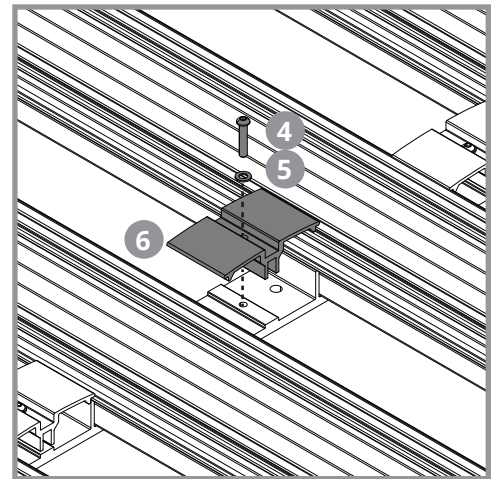
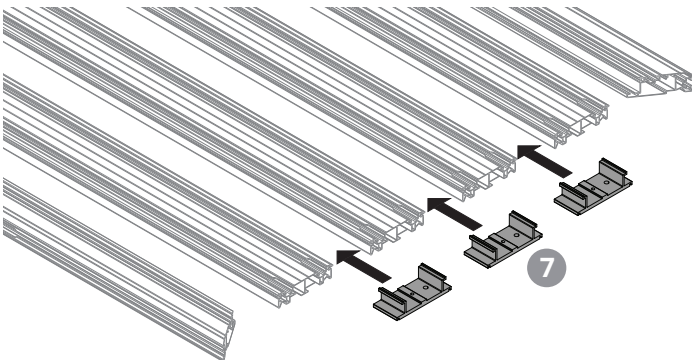

3

Refit the end plank of the Tray.

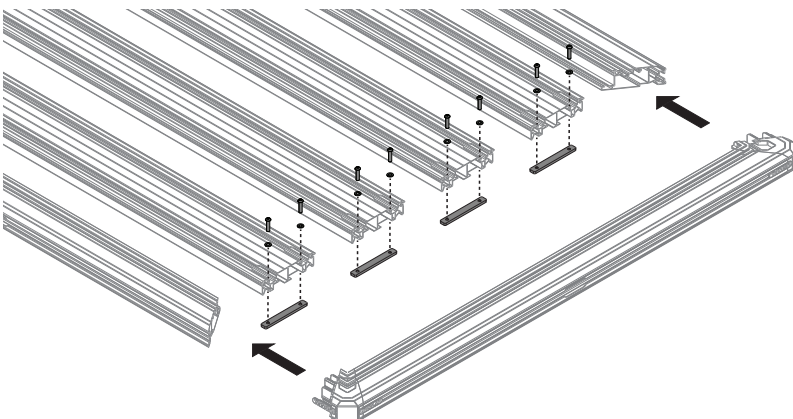

4

Slide 2x M6 Brass Nuts into each track.

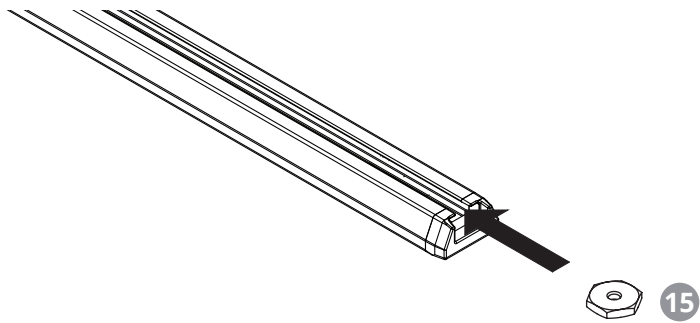

5

Install end supports. Finger tighten only at this stage.

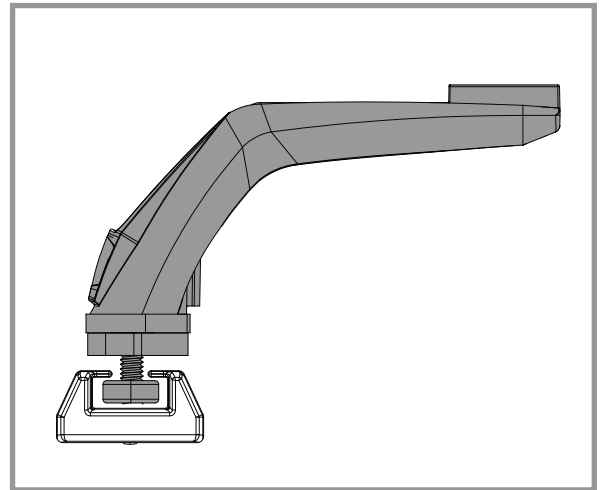
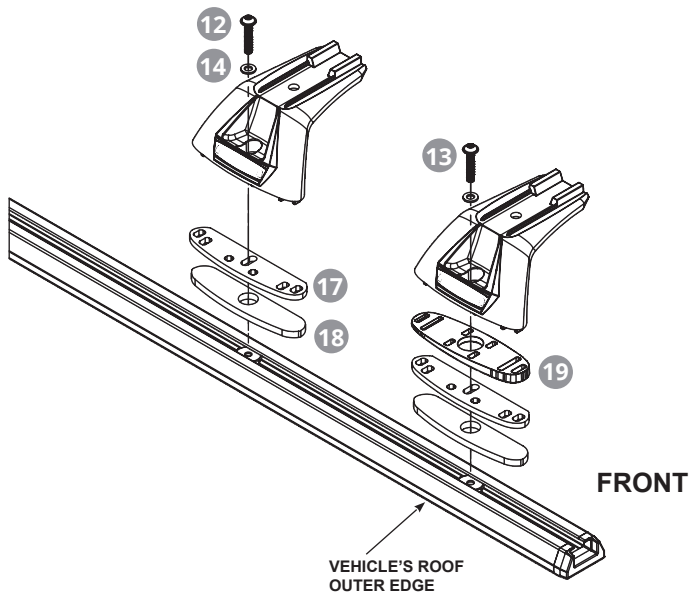

6

Insert hardware into the tray self support.

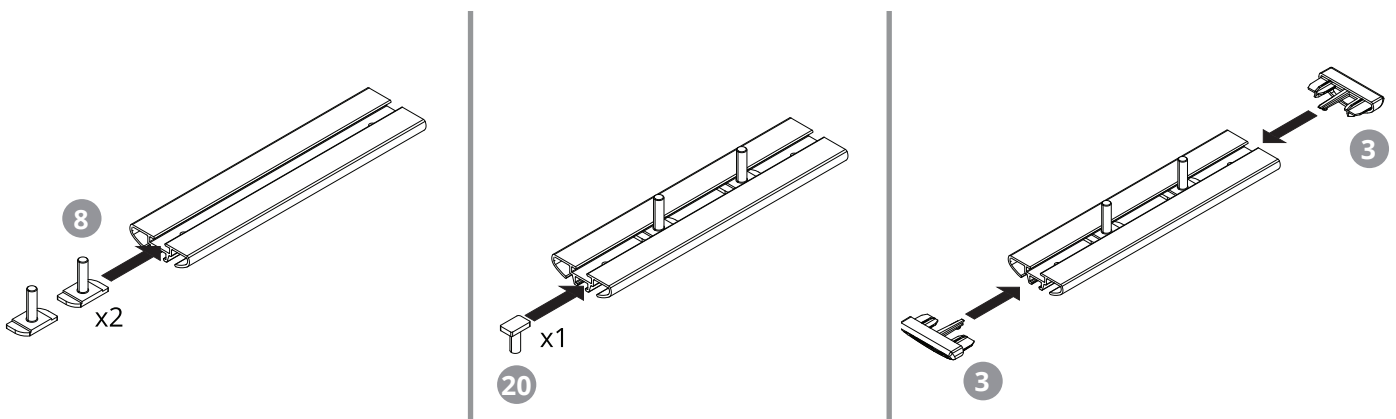

7

Fix the self supports to the mounting blocks.

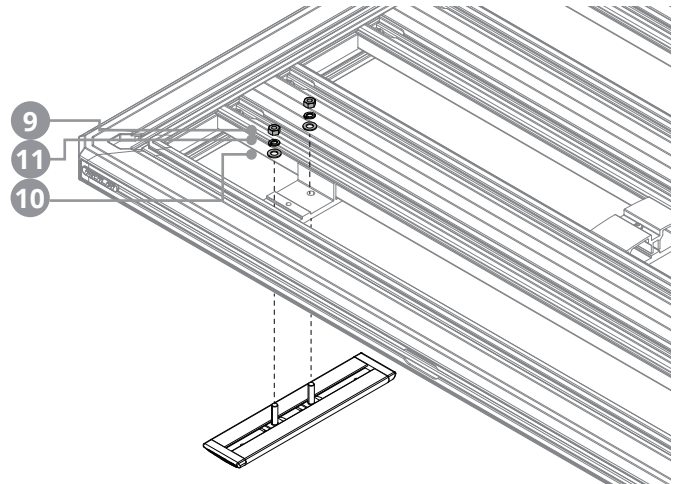

8

With assistance, lift the tray over the roof of the vehicle. Align the end supports with the hardware installed in the self supports. Lower the tray into place.

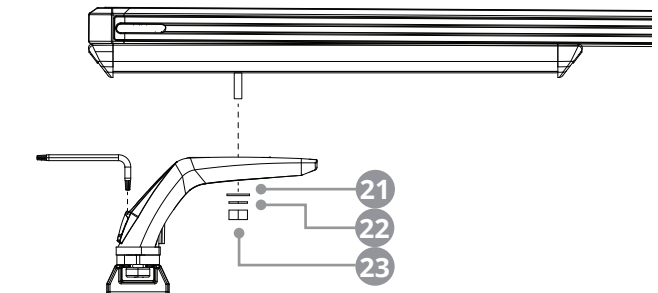
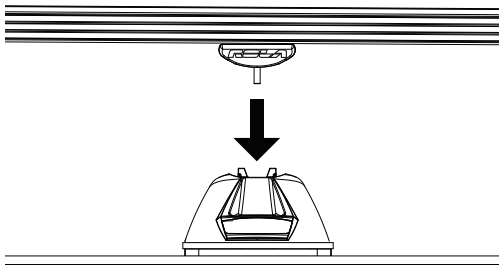

Finger tighten M8 hardware.
Secure end support with star drive.

9

Centre the tray and fix hardware in place

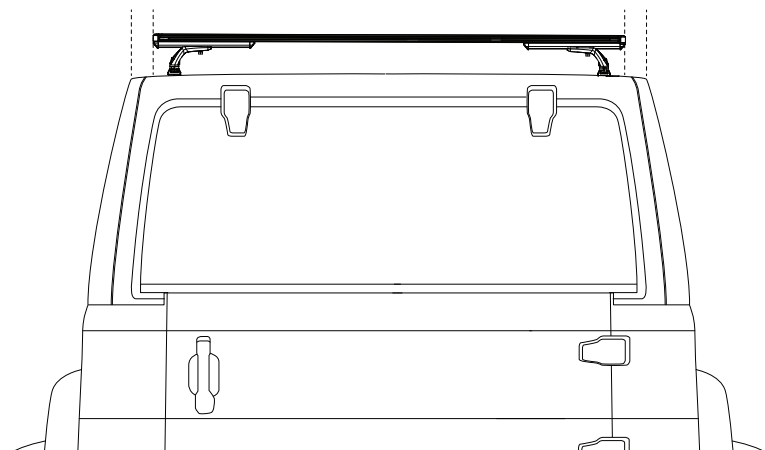

Tighten with 13mm socket.

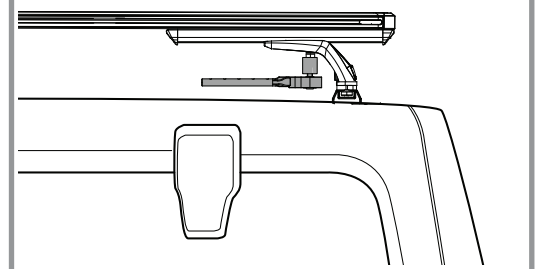

10

Measure the underside of the self supports, either side of the end support as shown.

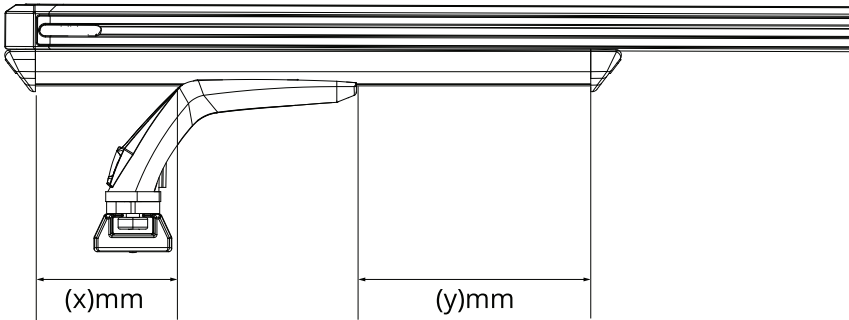

Cut the under cover strips to match measured dimensions.

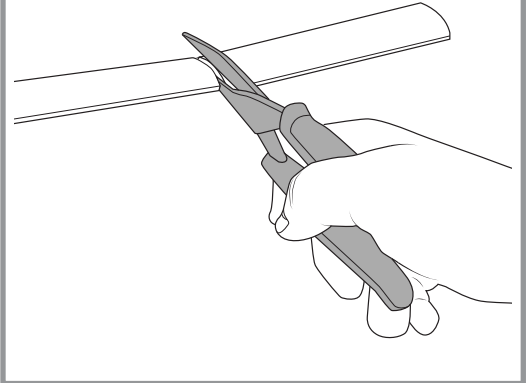

11

Insert the under cover strips into the self support.

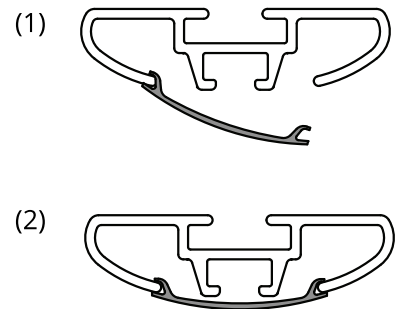
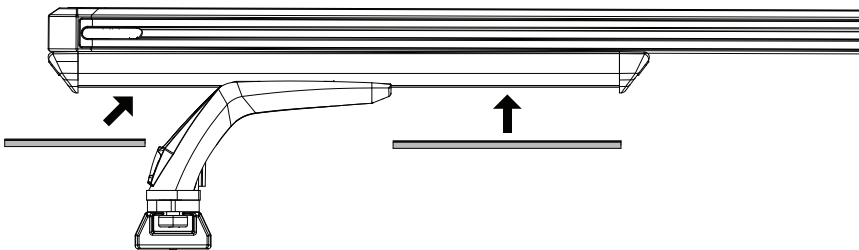

12

Ensure all fixtures are secure before use.

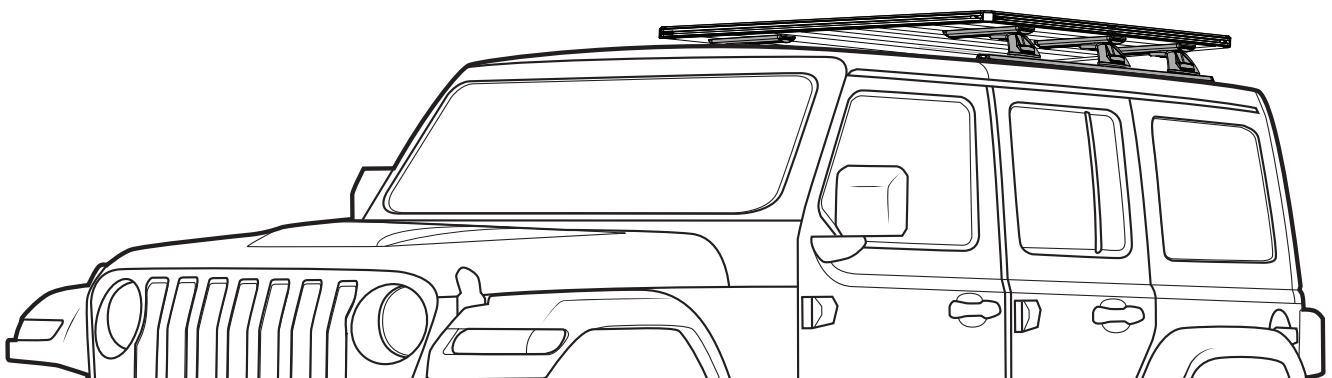

IMPORTANT - READ BEFORE USE

Please ensure the system is fitted in accordance with the fitting instructions. It is important that you observe all outlined below.

**WARRANTY INFORMATION**

Rola warrants that, subject to exclusions and limitations below, the system will be free from defects in materials and workmanship for a period of 5 years commencing on the date of sale by the authorized Rola stockist to the original purchaser of the system.

If a defect appears in the system before the end of the warranty period and Rola finds that the defect is in materials or workmanship, Rola will, in its sole discretion, either:

1. Repair the system or the defective component of the system free of charge
2. Replace the system or the defective component of the system; or
3. Refund the purchase price of the system to the original purchaser.

Rola reserves the right to change the design, specifications or composition of the system without notice and without liability.

Rola reserves the right to replace defective products or components with products or components of similar quality, grade and composition, where an identical product or component is not available. Goods presented for repair may be replaced by refurbished goods of the same type rather than being repaired. Refurbished parts may be used to repair the goods. The 2 year warranty does not apply where:

1. The system is not installed in compliance with the fitting instructions provided
2. The system is not used as intended or designed
3. The system has been on-sold or assigned by the original purchaser
5. The system has been modified or repaired by someone other than Rola or an authorized Rola stockist
6. Rola cannot establish any fault after inspection of returned product
7. The system has been subject to abnormal conditions, including fire, water, humidity, pressure, stress or similar
8. The defect in the system has arisen due to abuse, misuse, neglect or accident
9. The defect in the system has arisen due to the unlawful or unusual operation of the vehicle to which it is fitted
10. The defect in the system has arisen due to the purchaser's failure to properly assemble, install, fit, maintain or use the system in accordance with the specifications and instructions provided by Rola.

For safety and use instructions, please refer to any General or Specific Fitting Instructions and Warning & Care Instructions enclosed within the system or on our website at www.rola.com.au.

This warranty does not extend to fair wear and tear. Warranty claims can be made by contacting Rola directly using the details below. A warranty claim must be accompanied by proof of purchase (such as receipt), details of the alleged defect and appropriate documentation (such as historical and maintenance records where appropriate). The customer must make the product available to Rola or its authorized repair agent for inspection and testing. If such inspection and testing finds no defect in the product, the customer must pay Rola usual costs of service work and testing. It is the purchaser's responsibility to arrange and pay to return the product or component to the place of purchase. The purchaser may seek reimbursement from Rola for the cost of such activities, providing Rola notifies the purchaser in writing that a warranty claim is justified. Any such claims made must be in writing via post or email.

The benefits of this warranty are in addition to any rights and remedies imposed by Australian State and Federal legislation that cannot be executed. Nothing in this warranty is to be interpreted as excluding, restricting or modifying any State or Federal legislation applicable to the supply of goods and services which cannot be so excluded, restricted or modified. Our goods come with guarantees that cannot be excluded under the Australian Consumer Law. You are entitled to a replacement or refund for a major failure and for compensation for any other reasonably foreseeable loss or damage. You are also entitled to have the goods repaired or replaced if the goods fail to be of acceptable quality and the failure does not amount to a major failure. Rola makes no express warranties or representations other than set out in this warranty.

SAFETY REQUIREMENTS

Manufactures roof weight limit - rack system weight = Max carrying capacity.

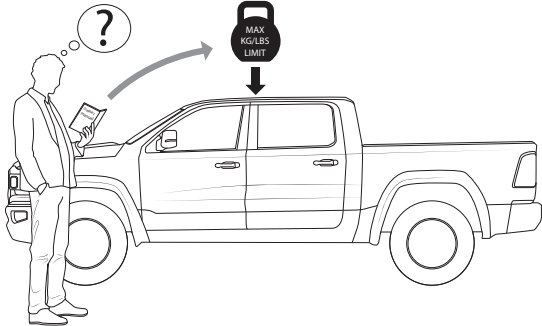

Cross reference with system max carrying capacity. **Always use the lower of the two figures.**

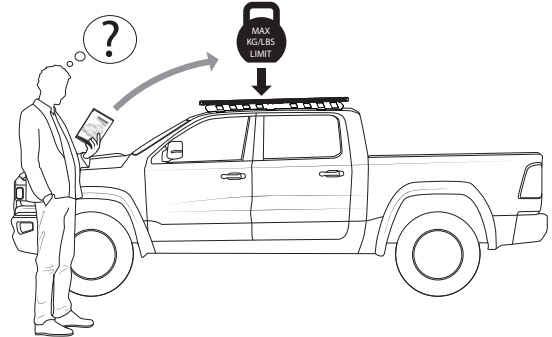

IMPORTANT - Off-road load rating reduction.

System	Track Mount	Anchor Point	Gutter Mount	Raised Rail	Flush Rail	Clamp Mount
Tray+ Ridge Mount	0%	0%	25%	0%	N/A	N/A
Tray+ Low Mount	33%	33%	33%	33%	33%	50%
Sports Extended	33%	33%	33%	33%	33%	50%
Sports Concealed	33%	33%	33%	33%	33%	50%

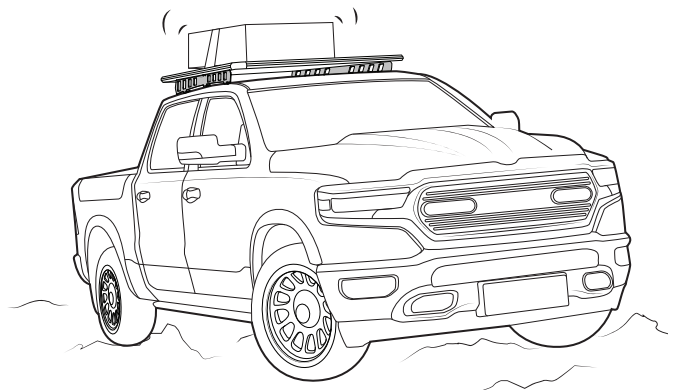

Distribute carried load evenly longitudinally and as low as possible. Do not concentrate loads front or rear.

CORRECT

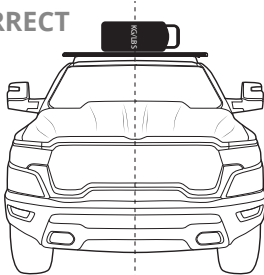

CORRECT

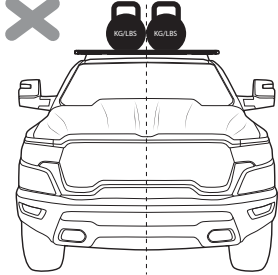
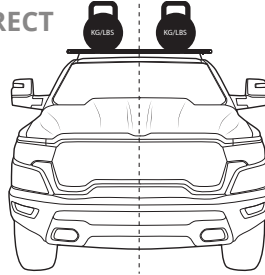

CORRECT

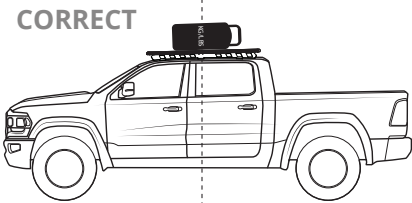

CORRECT

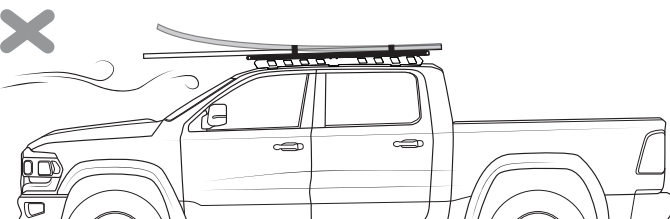
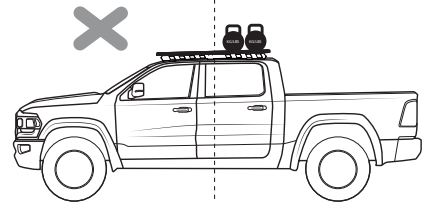
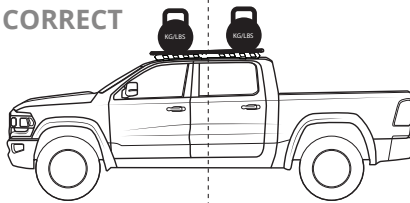

CORRECT

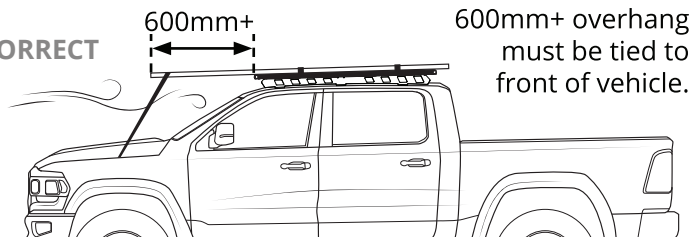

600mm+ overhang must be tied to front of vehicle.

SAFETY REQUIREMENTS

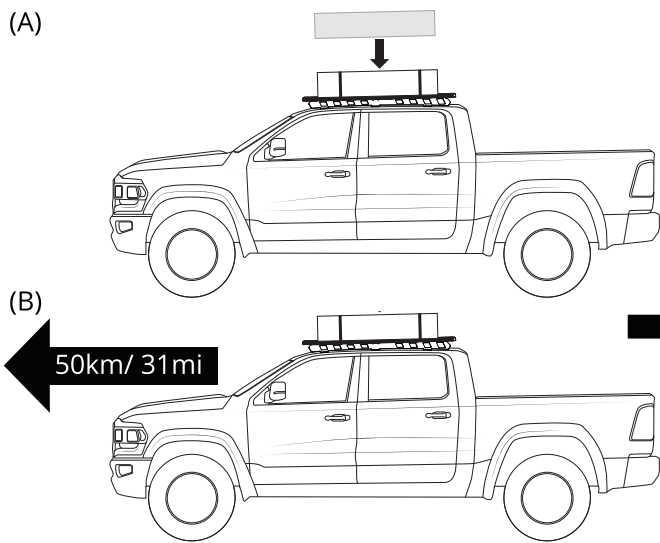

Check all fixtures are secured and torqued correctly.

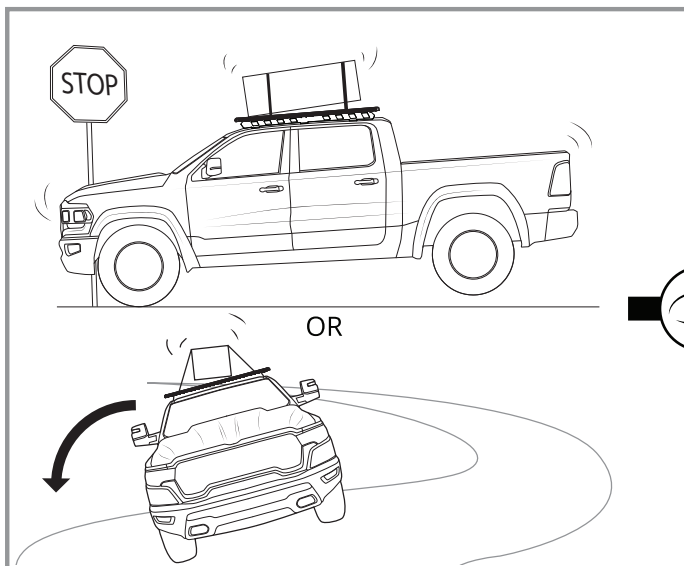
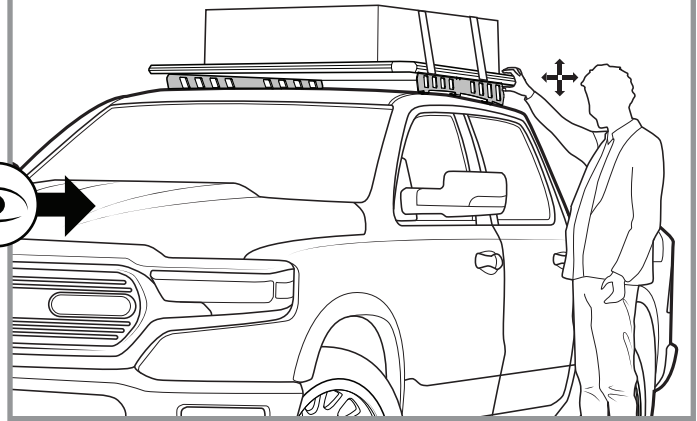

Check all fixtures are secured and torqued correctly.

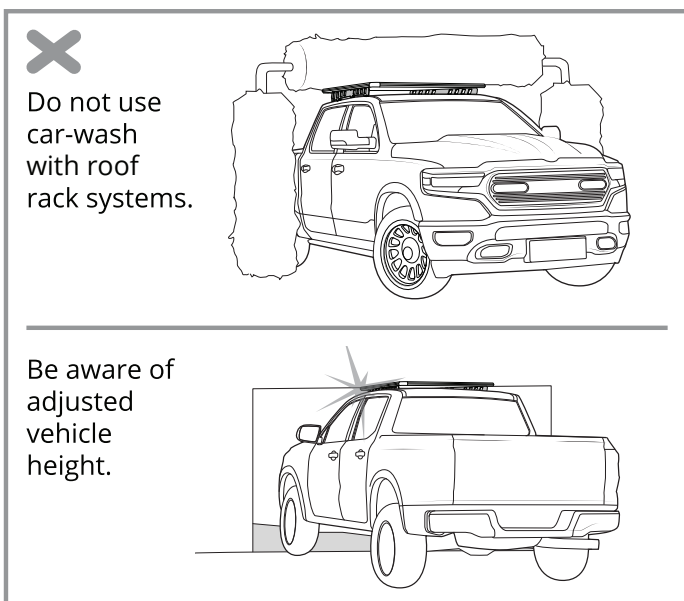
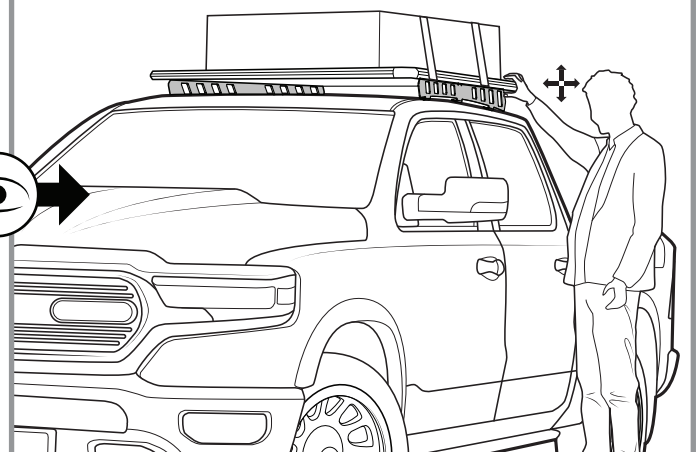

Cab and canopy can move independently, do not fix load across both.

Long loads fixed at front only.

