

ROLA®

R-PBR-01 BIKE RACK

ASSEMBLY PARTS

PN	DESCRIPTION	QTY
1	Draw bar	1
2	Rear wheel cradle	2
3	Hook driver side	1
4	Hook passenger side	1
5	Lateral tube with support arm	2
6	Base bar	1
7	Lateral tube	2
8	Driver side wheel holder	1
9	Passenger side wheel holder	1

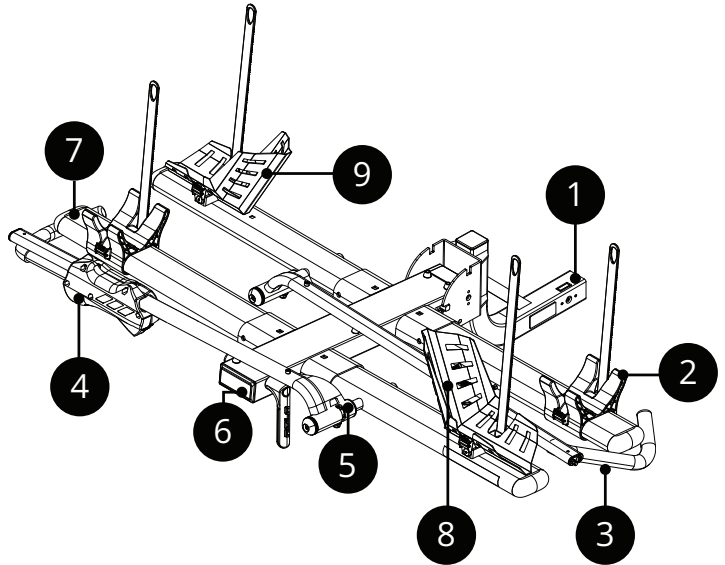

ASSEMBLY HARDWARE

PN	DESCRIPTION	QTY
10	M10 Nut	8
11	M10 x12 washer	12
12	M10 Cup head bolt	4
13	M10 Button head screw	4
14	1/2" btn screw	1
15	M8 Cup head bolt	1
16	Nut tightening tool	1
17	Safety strap	1
18	Security star drive	1
19	6mm Hex wrench	1
20	8mm Hex wrench	1
21	1/2" nut	1
22	12.5mm washer	2
23	M8 nut	4
24	M8 washer	4
25	M6 Security btn screw	2
26	Shake proof washer	1
27	13mm Large washer	1
28	Locking washer	2
29	Hitch pin	1
30	Key	2
31	Barrel	1
32	U-bolt assembly	1
33	Anti rattle plate	1
34	Wheel strap cover	4

IMPORTANT: Check all qty are correct before starting fitment.

Max load: 30kg per bike



IMPORTANT: Suitable for gazetted dirt roads.

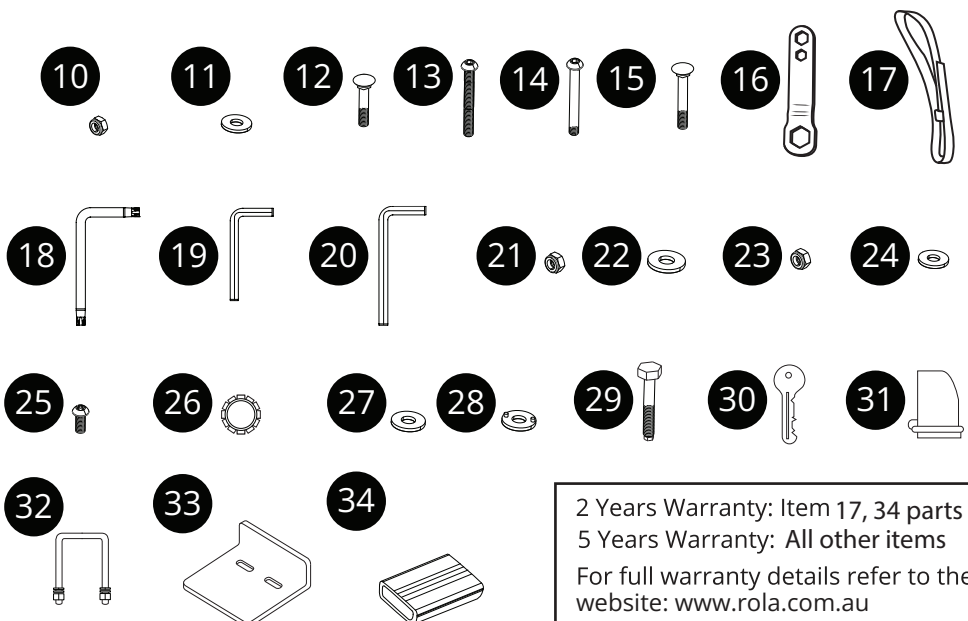

2 Years Warranty: Item 17, 34 parts of 8,9,2
 5 Years Warranty: All other items
 For full warranty details refer to the website: www.rola.com.au

ISSUE:01
 12/04/26

JUST ADD ADVENTURE

ROLA

ROLA®

R-PBR-01 BIKE RACK

1

Slide the hitch tube into the vehicle receiver, secure it with a the hitch pin, shake proof washer and flat washer. Lock with the provided barrel.

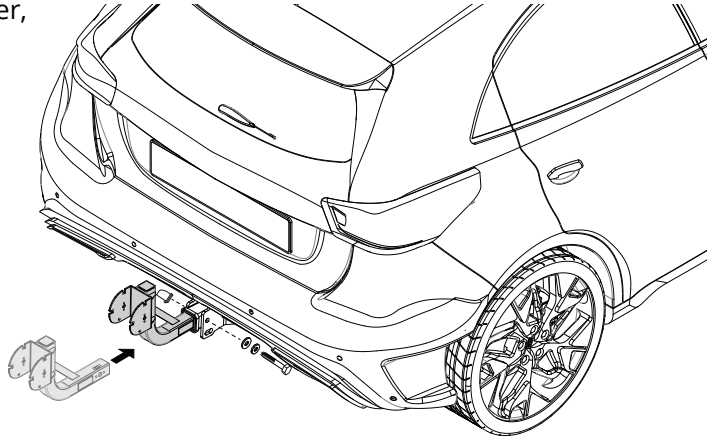
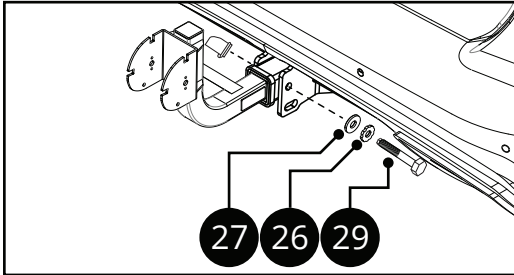

2

Install the two locking washers. This may require a second person to hold the washers in place.

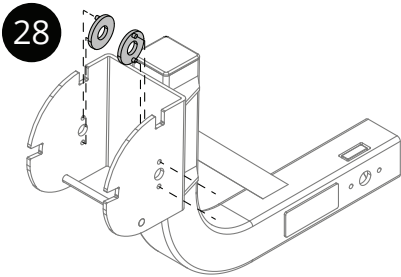

3

Connect the base bar as shown.

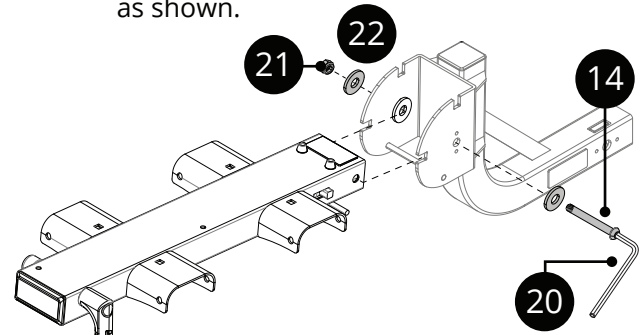

4

Install both lateral tubes and tubes with support arms as shown. Fix in place with M10 hardware. Note: thread does not protrude from nyloc.

Slide the rear cradles into position on the lateral tubes. Install so buckles face outward from the vehicle for ease of use.

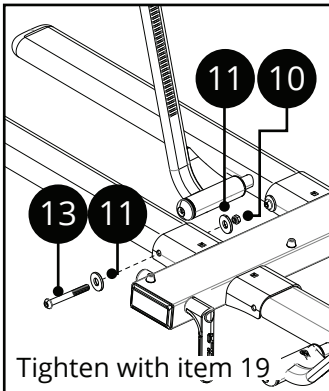
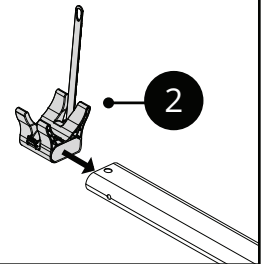

Note: Screw head points towards ground.

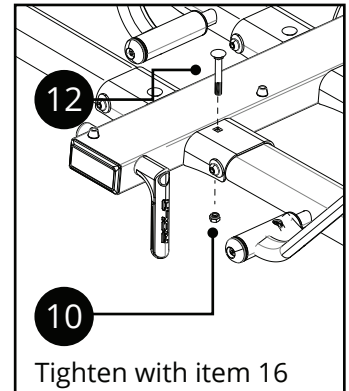

JUST ADD ADVENTURE

ROLA

5

Install the wheel holders using M8 hex bolts, flat washers and nuts. Note: Wheel holder must face corresponding sides of vehicle.

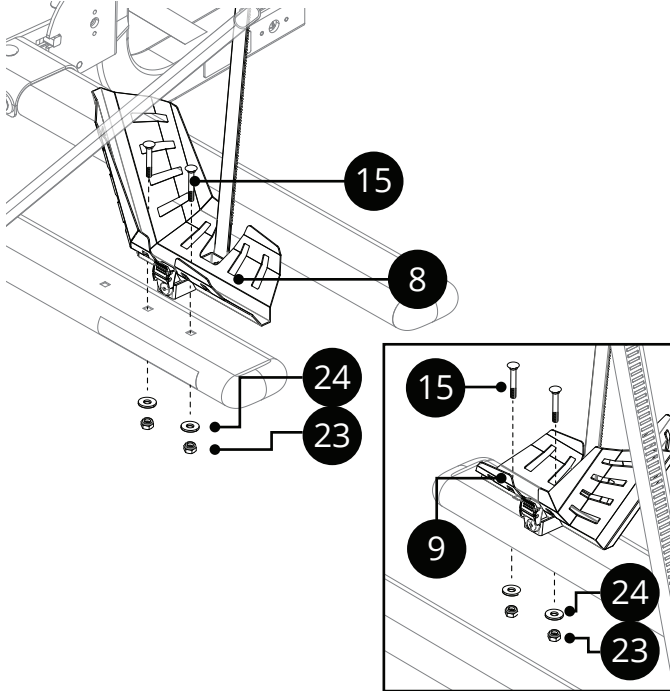

Install wheel strap overs (ITEM 34).

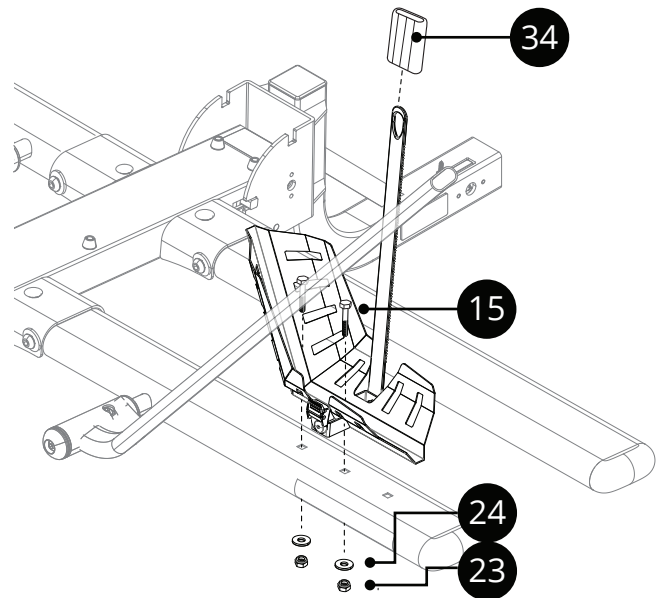

Note: Use the rear mounting holes if the wheel size is less than 24".

6

Slide the hooks on the support arms. With the hooks in place, fix an M6 security button screw into the end of each arm. This will stop the hook sliding back off the support arm.

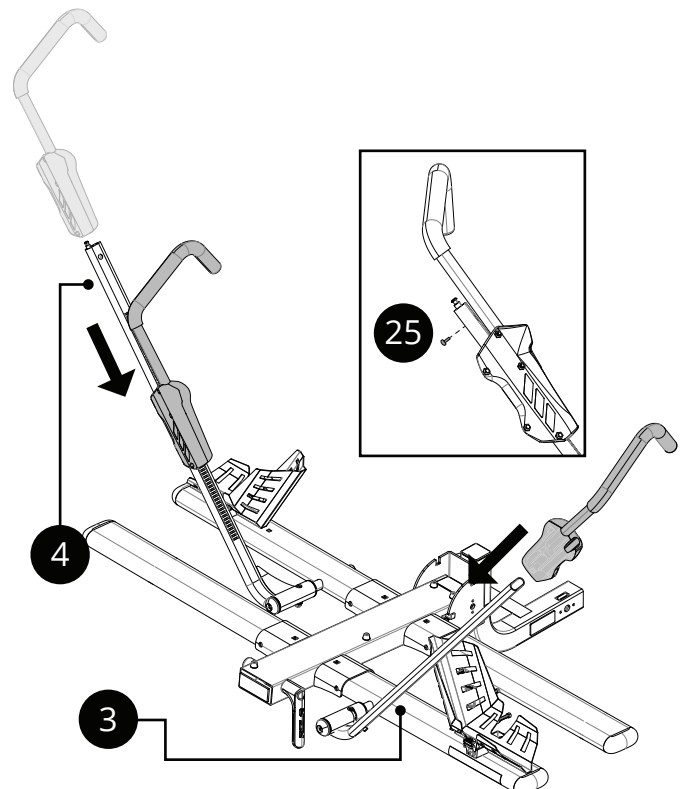

7

Load the bike onto the carrier, closest to the rear of the vehicle first. Ensure both wheels of the bikes are sitting in the bike carrier wheel holders and cradles as shown. Lift the hook up and clamp down onto the front wheel, as close to the fork as possible.

IMPORTANT: Wheels must not be flat or low on air. Failure to adhere may result in bike coming loose.

Place bike onto carrier.

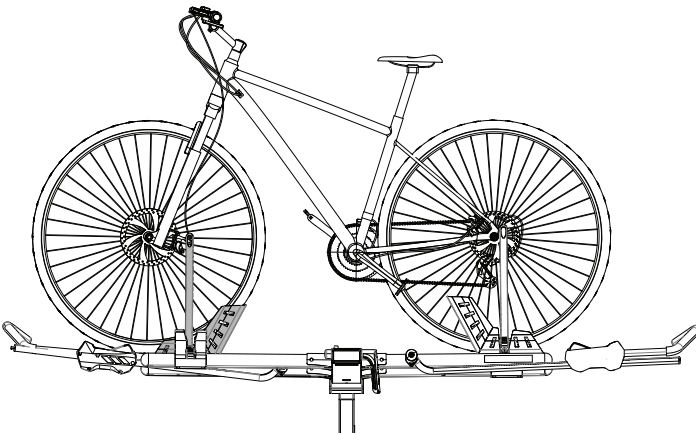

Lift the support arm up and into position. Ensure no contact with the front forks and support arm hook.

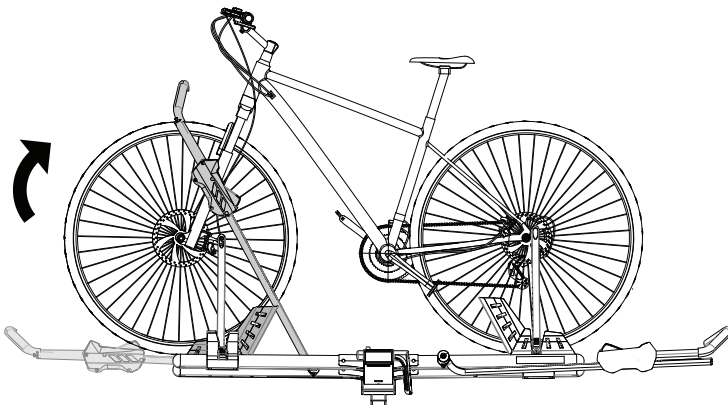

Pull clamp down and onto the wheel, securing it.

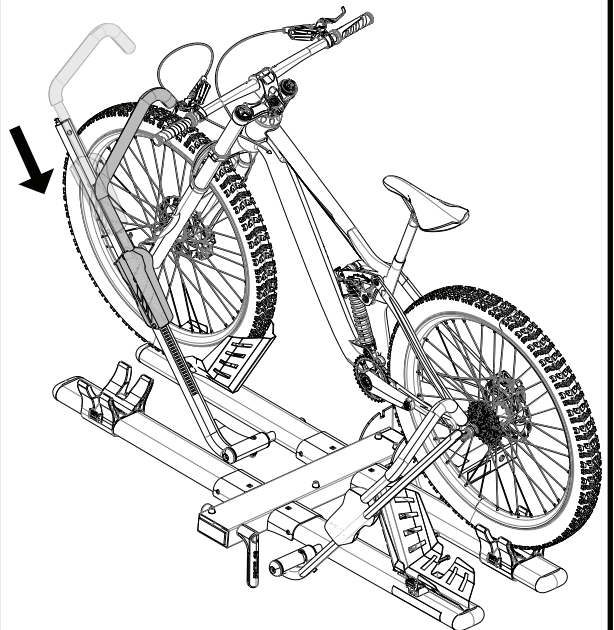

Note: Ensure the wheels are inflated. Loss of tyre pressure may cause instability of the bike on the platform.

8

Pull the locking cable from the support arm and wrap around the frame of the bike. Lock its end back into the support arm as shown.

This will deter theft.

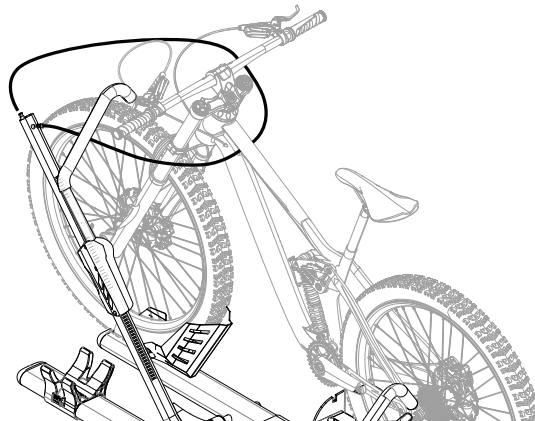

9

Ensure the rear cradle is adjusted to sit directly under the rear wheel. Secure the front and rear wheel, using the ratchet straps. Ensure the ratchet buckle is engaged and the wheels are sure.

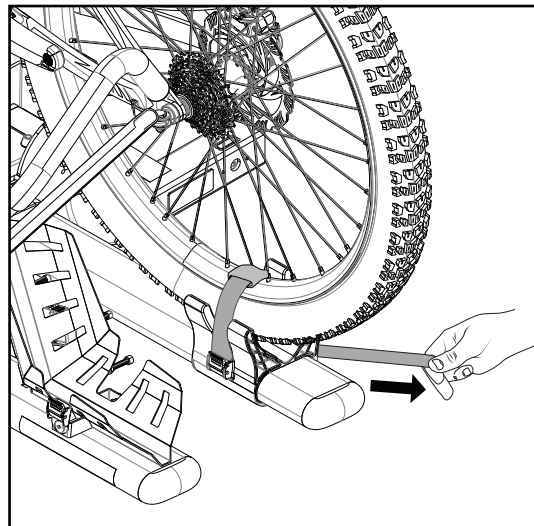
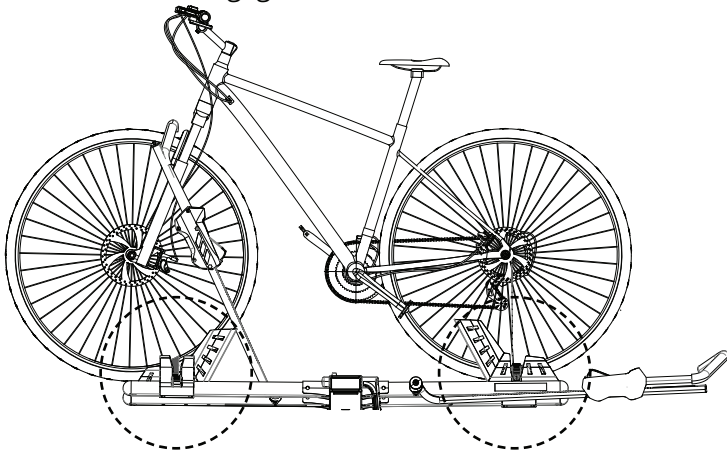

10

Install the safety strap before use on gazetted dirt roads. Ensure all moving components are tightened and secure before each trip, with or without bikes loaded. The strap is not required for bitumen roads.

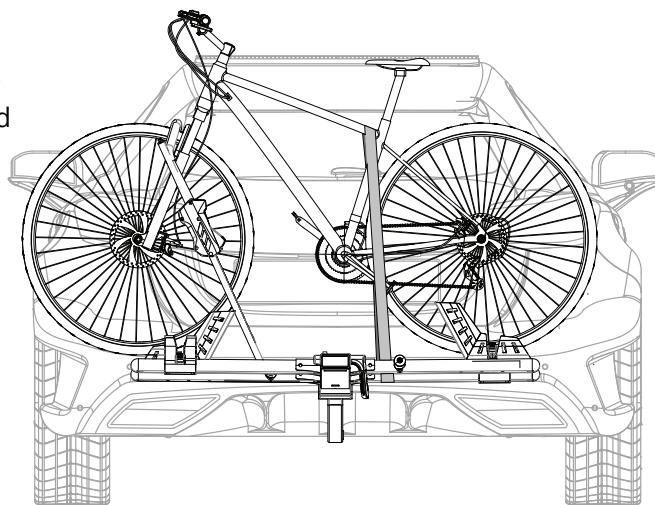

11

To use the tilt function, pull the quick release lever and lower the rack.

CAUTION: The rack will be heavy when loaded. Only use this function when parked and with assistance.

Do not allow the rack to fall freely into position.

Always return the rack to its level position before driving.

Use two hands when lowering the system.

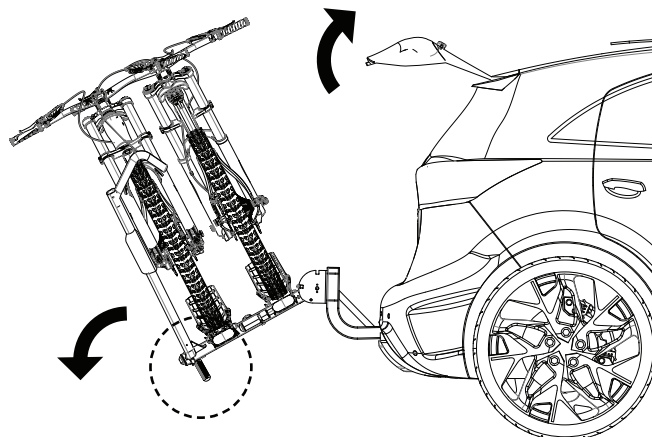

12

When not in use, store in the upright position.

Ensure the hooks are positioned behind the rack, this will ensure they do not swing forward and touch the vehicle.

Put the arms back down.

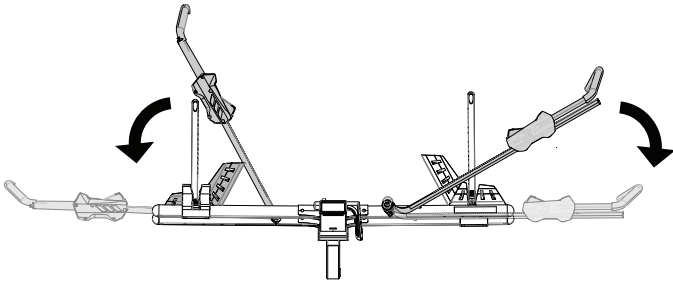

Once down, push the clamps into their lowest position as shown. The hook of the clamp should slip under the lateral tubes, securing them in place.

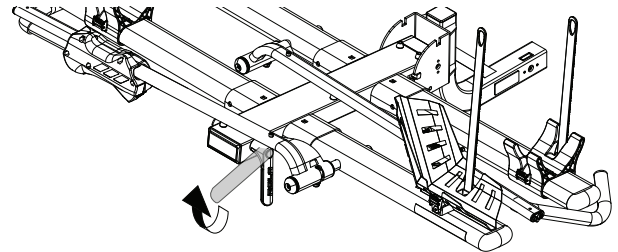
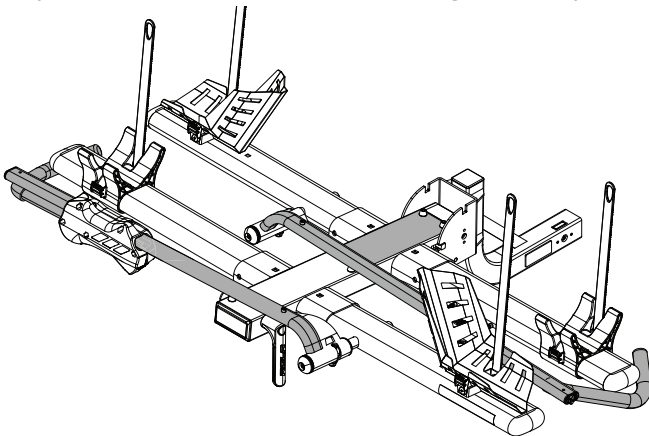

Pull the locking lever to lift up the rack into the upright position.

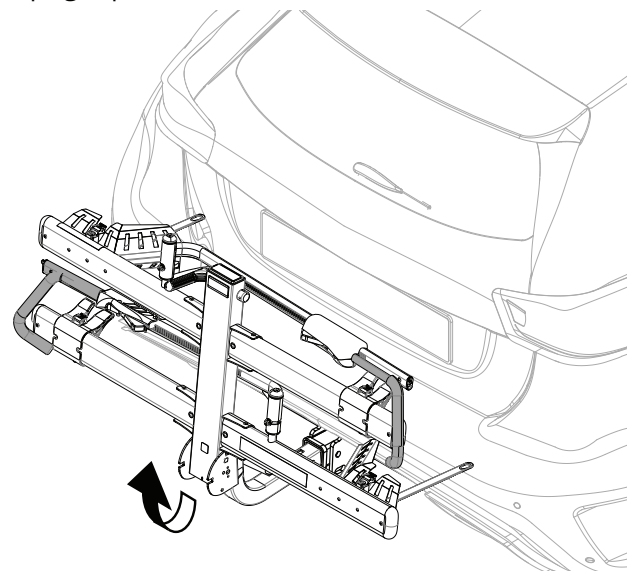

CARRIER INFORMATION

Warning during fitting of the rack.

1. When vehicle is equipped with power tailgate, do not open or close the door, while the system is in the vertical position.
2. Please obey the local traffic laws when using rack.
3. Please remove the bike rack when not in use or before using carwash.

Warning during mounting of bikes

1. Before mounting bicycle, please remove all loose items.
2. Tires of bicycles have to be kept away from vehicle exhaust.
3. Always obey the weight limit of each bicycle (max. 30kg per bike) and capacity of bicycles according to manufacturer's recommendation. Please do not carry recumbent.
4. Vehicles installed with bike carriers will have different road behavior. Drive with extreme caution.
5. Vehicles equipped with bike carriers will have extended width and length.
6. Some bike frame styles will require a bike beam to mount.
7. Check installation every 100km to ensure all fixtures are secure.

Important notices regarding to warranty and liability

1. Please refer to the enclosed warranty policy.
2. Ensure bike tyres are fully inflated before using the system.

IMPORTANT - READ BEFORE USE

Please ensure the system is fitted in accordance with the fitting instructions. It is important that you observe all outlined below.



WARRANTY INFORMATION

Rola warrants that, subject to exclusions and limitations below, the system will be free from defects in materials and workmanship for a period of 5 years (unless otherwise specified) commencing on the date of sale by the authorized Rola stockist to the original purchaser of the system.

If a defect appears in the system before the end of the warranty period and Rola finds that the defect is in materials or workmanship, Rola will, in its sole discretion, either:

1. Repair the system or the defective component of the system free of charge
2. Replace the system or the defective component of the system; or
3. Refund the purchase price of the system to the original purchaser.

Rola reserves the right to change the design, specifications or composition of the system without notice and without liability.

Rola reserves the right to replace defective products or components with products or components of similar quality, grade and composition, where an identical product or component is not available. Goods presented for repair may be replaced by refurbished goods of the same type rather than being repaired. Refurbished parts may be used to repair the goods. The 5 year (unless otherwise specified) warranty does not apply where:

1. The system is not installed in compliance with the fitting instructions provided
2. The system is not used as intended or designed
3. The system has been on-sold or assigned by the original purchaser
5. The system has been modified or repaired by someone other than Rola or an authorized Rola stockist
6. Rola cannot establish any fault after inspection of returned product
7. The system has been subject to abnormal conditions, including fire, water, humidity, pressure, stress or similar
8. The defect in the system has arisen due to abuse, misuse, neglect or accident
9. The defect in the system has arisen due to the unlawful or unusual operation of the vehicle to which it is fitted
10. The defect in the system has arisen due to the purchaser's failure to properly assemble, install, fit, maintain or use the system in accordance with the specifications and instructions provided by Rola.

For safety and use instructions, please refer to any General or Specific Fitting Instructions and Warning & Care Instructions enclosed within the system or on our website at www.rola.com.au.

This warranty does not extend to fair wear and tear. Warranty claims can be made by contacting Rola directly using the details below. A warranty claim must be accompanied by proof of purchase (such as receipt), details of the alleged defect and appropriate documentation (such as historical and maintenance records where appropriate). The customer must make the product available to Rola or its authorized repair agent for inspection and testing. If such inspection and testing finds no defect in the product, the customer must pay Rola usual costs of service work and testing. It is the purchaser's responsibility to arrange and pay to return the product or component to the place of purchase. The purchaser may seek reimbursement from Rola for the cost of such activities, providing Rola notifies the purchaser in writing that a warranty claim is justified. Any such claims made must be in writing via post or email.

The benefits of this warranty are in addition to any rights and remedies imposed by Australian State and Federal legislation that cannot be executed. Nothing in this warranty is to be interpreted as excluding, restricting or modifying any State or Federal legislation applicable to the supply of goods and services which cannot be so excluded, restricted or modified. Our goods come with guarantees that cannot be excluded under the Australian Consumer Law. You are entitled to a replacement or refund for a major failure and for compensation for any other reasonably foreseeable loss or damage. You are also entitled to have the goods repaired or replaced if the goods fail to be of acceptable quality and the failure does not amount to a major failure. Rola makes no express warranties or representations other than set out in this warranty.