

Fitting Instructions



SKU

PRODUCT

T7K697

TAG Heavy Duty Towbar to suit Hyundai Tucson (2019 - on), KIA Sportage (2019 - on)



T7K697

Scan for latest
version of these
instructions

SPECIFICATIONS

- Towbar Class: Standard Duty
- Towing Capacity: 1900kg

IN THIS GUIDE

- Fitment Instructions
- Torque Settings
- Warranty Info

Towbar Fitting Instructions



Step-By-Step Instructions

Warning:

Safety First: Always use correct safety equipment.

This towbar is NOT to be drilled, cut, welded or modified in any way.

Check the surrounding area before drilling into chassis or body panels for fuel lines, wiring harnesses and other components that may be a hazard.

General:

Before fitting this towbar read fitting instructions and check installation hardware is correct.

Check that the towbar is suitable for the vehicle and be wary of any changes to the vehicle design that may conflict with the fitting of this towbar.

After drilling, blow any filings clear, remove any swarf and treat exposed metal with a rust inhibitor.

If this vehicle requires a bumper cut out, please check to make sure that you measure twice and check twice before cutting any panels as some bumper profiles can change.

If you are not sure then ask your towbar supplier.

Tighten all bolts as specified on the last page.

Towbar Fitting Instructions



Kit Contents					
Item #	Description	Qty	Item #	Description	Qty
1.	Towbar (T7K697)	1	5.	M10 Flat Washer	16
2.	M10x1.25x40 Bolt	10	6.	M10 Shake Proof Washer	10
3.	Outer Chassis rail plate	2	7.	M10 Square Plate	2
4.	M10x1.25 Nut	6	8.	M10 Dual Slot Plate	2
9.	Towbar Info Label	1	-	-	-

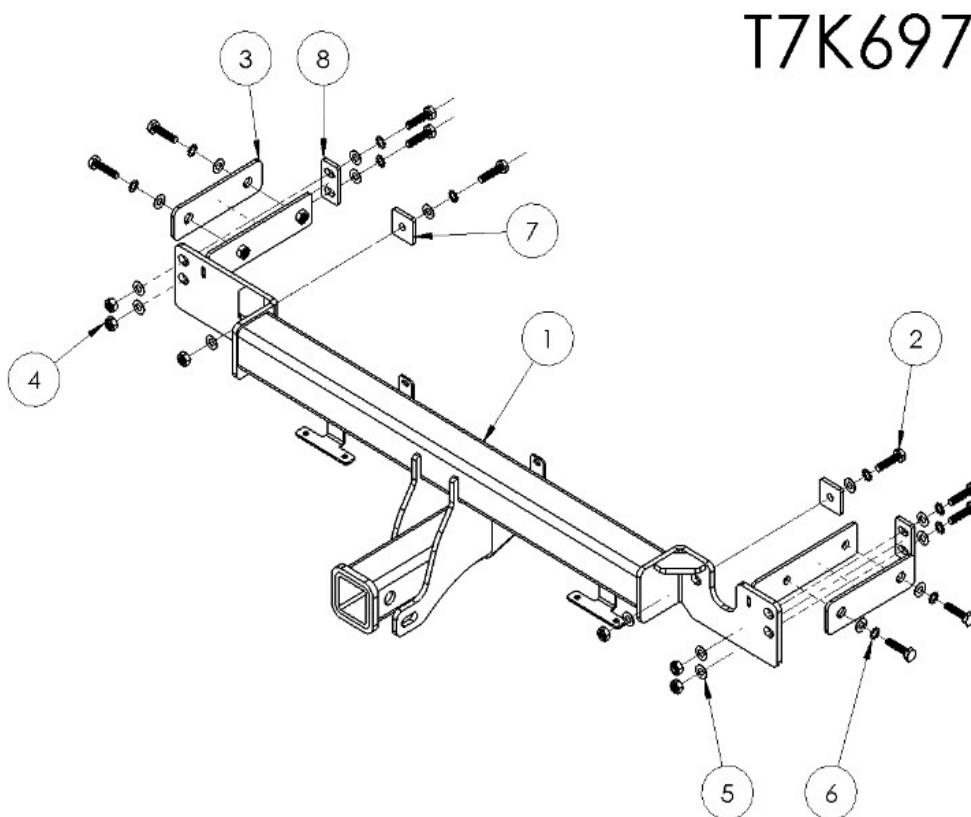

T7K697

Torque Table for Bolt Tightening

Metric GRADE 8.8	UNC GRADE 8
M6 – 12.5 Nm	3/8 – 50 Nm
M8 – 30 Nm	1/2 - 125 Nm
M10 – 60 Nm	5/8 – 245 Nm
M12 – 103 Nm	
M14 – 167 Nm	

Towbar Fitting Instructions



- If this vehicle requires a bumper cut out, please check to make sure that you measure twice and check twice before cutting any panels as some bumper profiles can change.
- If you are not sure, then please ask your towbar supplier

Step 1	Remove Tail Lights	
Instructions	Tools	Fasteners/Torques
<p>Remove/unclip the plastic cover on the tail light (both sides). Unscrew 2x tail light fasteners and remove the tail light. Unplug the light. (both sides).</p>	<p>Trim Removal Tools. Philips head screwdriver</p>	<p>NA</p>

Step 2	Remove Bumper Clips	
Instructions	Tools	Fasteners/Torques
<p>Remove 2x plastic clips from inside the tail light cavity (both sides). Unclip 3x plastic rivets on the bottom of the rear bumper.</p>	<p>Trim Removal Tools</p>	<p>NA</p>

Towbar Fitting Instructions



Step 3	Remove Mud Guards and Plastic Covers	
		
Instructions	Tools	Fasteners/Torques
<p>Unscrew 4x fasteners and remove mud flaps (both sides). Unclip 3x push rivets and remove plastic covers behind each rear wheel.</p>	<p>Screwdriver Trim removal tools</p>	<p>NA</p>

Step 4	Unbolt impact beam from chassis	
		
Instructions	Tools	Fasteners/Torques
<p>Remove 3x bolts at the end of the chassis rail, for the impacts beam (both sides)</p>	<p>M10 spanner/socket</p>	<p>NA</p>

Towbar Fitting Instructions



Step 5	Remove Rear Bumper	
Instructions	Tools	Fasteners/Torques
<p>Unclip and remove the rear bumper. Disconnecting any applicable wiring looms. Remove impact beam from bumper and discard. Where applicable detach smart key antenna and wiring from the impact beam.</p>	<p>NA</p>	<p>NA</p>

Step 6	Position Towbar	
Instructions	Tools	Fasteners/Torques
<p>Position Towbar as shown.</p>	<p>NA</p>	<p>NA</p>

Towbar Fitting Instructions





Step 7	Fasten Towbar to Vehicle Using Supplied Hardware	
Instructions	Tools	Fasteners/Torques
<p>(Loosely secure hardware initially, then when all hardware is in place torque to noted spec)</p> <ul style="list-style-type: none"> - Use largest dual hole plate, along with 2x M10 bolts, shake proof and flat washers to fasten through the side of the chassis rail into the nuts welded to the towbar. - Use the smaller slotted dual hole plate, along with 2 x M10 bolts, nuts, shake proof washers, and 4x flat washers to fasten the towbar to vehicle through the outer rear facing holes. - Use 1x M10 bolt, nut, shake proof washer and 2x flat washers, to fasten the towbar to the vehicle through the inner rear facing holes. 	<p>M10 Spanner, Socket Torque Wrench</p>	<p>M10 Bolt Shake Proof Washer Flat Washer M10 Nut (60Nm)</p>

Step 8	Cut Bumper	
<p>Viewed directly from below</p>		
Instructions	Tools	Fasteners/Torques
<p>Locate the centre of the bumper along the bottom edge. Viewing from directly beneath the bumper, create bumper cut as shown in the diagram. Note: this is a guideline and may need to be modified if the bumper is still in contact with the towbar.</p>	<p>Air Saw</p>	<p>NA</p>

Towbar Fitting Instructions

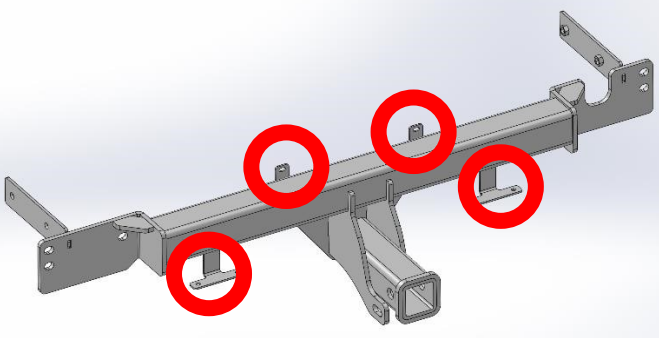

Step 9	Refit Bumper, Plastic Trim, Mud Guards & Tail lights	
		
Instructions	Tools	Fasteners/Torques
<ul style="list-style-type: none"> Complete steps 1-5 in reverse to refit the bumper, plastic trim, mud guards and tail lights, using hardware removed from the vehicle previously. Use 2x lower push rivets from lower edge of the bumper to clip this edge to the lower tabs on the towbar as shown. - Clip the sensors that were detached from the impact beam to the tabs on upper tabs on the towbar. 	Screwdrivers	NA

Step 10	Apply Sticker to Door Jam	
		
Instructions	Tools	Fasteners/Torques
Apply Towbar info label to the inside of the driver's side door Jam.	NA	NA

Towbar Fitting Instructions



Torque Table for Bolt Tightening

Metric GRADE 8.8	UNC GRADE 8
M6 – 12.5 Nm	3/8 – 50 Nm
M8 – 30 Nm	1/2 – 125 Nm
M10 – 60 Nm	5/8 – 245 Nm
M12 – 103 Nm	
M14 – 167 Nm	
M16 – 270 Nm	

TAG Warranty Statement

SWD warrants your TAG Towbar for its full product life under the following conditions:

- You can show proof of purchase.
- The towbar has been correctly installed by a suitably qualified installer.
- The towbar has not been modified or abused in any way and has only been used for the purpose intended.
- The towbar was not fitted second hand to your vehicle.

The extent of this warranty includes materials and workmanship used in the manufacture of the towbar and is to the equivalent value of current, full replacement cost.

Nothing stated or implied in this warranty limits in any way, the statutory rights that you may have.

To make a claim visit the original installer in the first instance or, if you are unable to or are not satisfied with their help, then contact us direct by phone on 1300 669122 or visit www.swd.com.au