

RIDGE MOUNT

by **ROLA**[®]

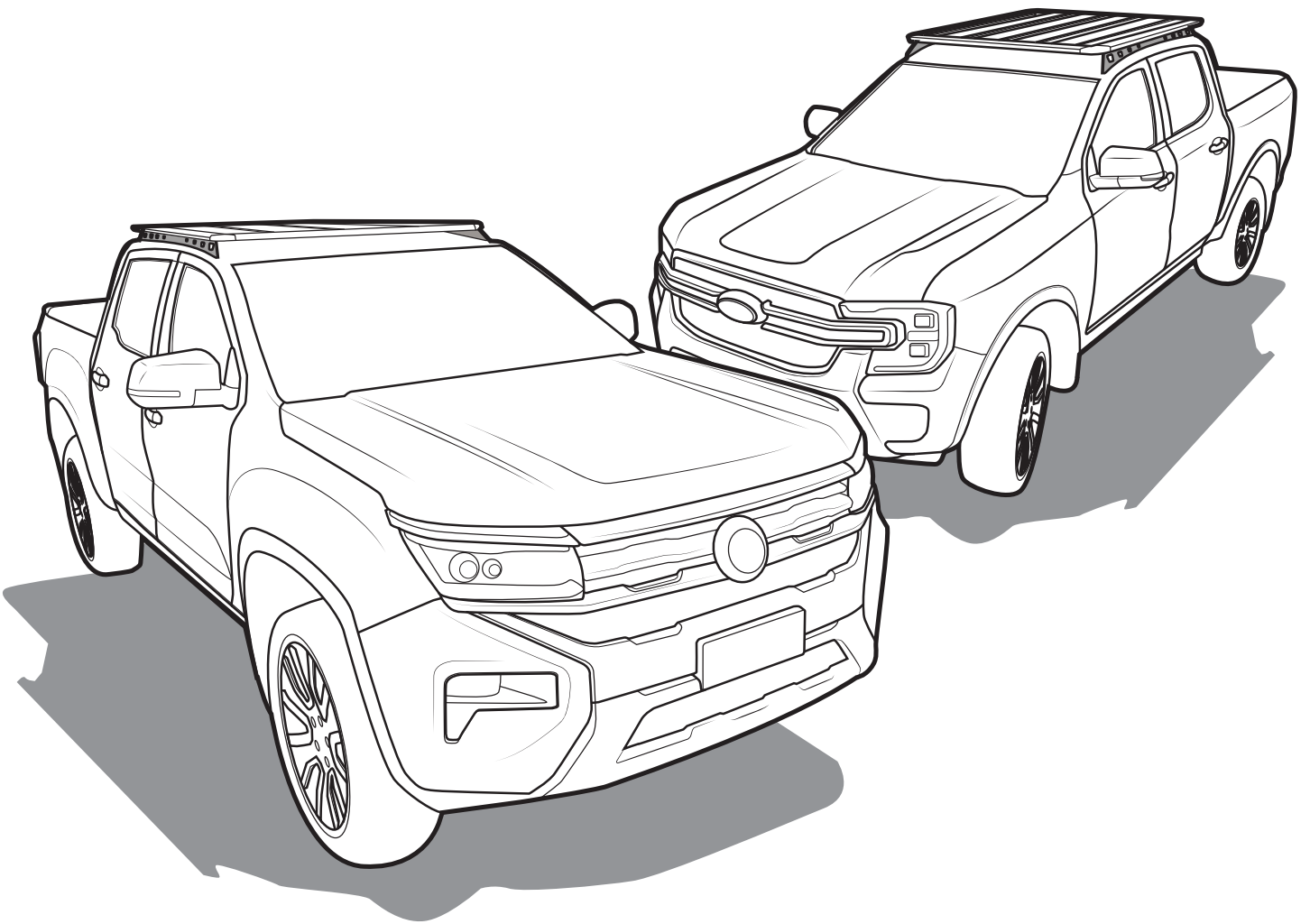

Read this full instruction prior to commencing assembly and fitment of Ridge Mount System.

CONTENT - CHECK ALL PARTS ARE CORRECT BEFORE PROCEEDING

A		Ranger Ridge Mount (pair)	1
B		Stud plate	4
C		M6x16mm Cap screw	4
D		M6 Spring washer	4
E		M6 Flat washer	4
F		M6 Flanged nut	4
G		Sealant patch	8
H		Interlocking Block	3
I		M8 x 30mm button head screw	8
J		M8 Flat washer	24
k		M8 Nyloc nut	8

TOOLS REQUIRED

- 5/6mm allen tool.
- 13mm and 17mm socket wrench.
- Step ladder.
- Trim tools.
- Screwdriver.
- Torx Bits.
- Marker.
- Cutter.

1

Move to the side of the vehicle. Use a step ladder to get access to the vehicle.

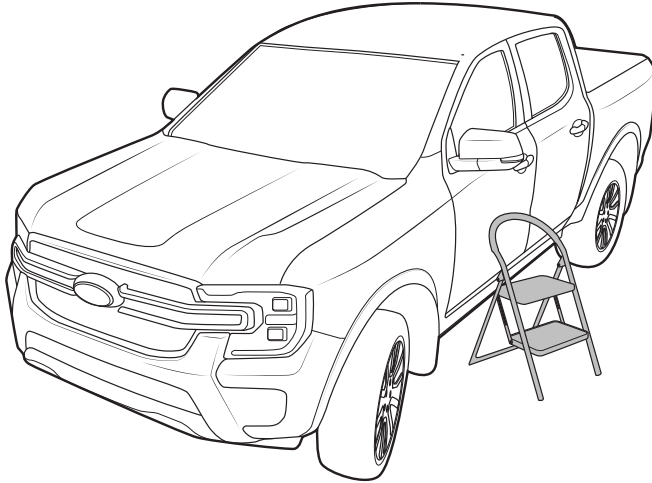

WARNING:

Disconnect battery before removing roof liner. To ensure all power has dissipated from the capacitors pump the brakes a few times and turn the lights on and off.

2

Be sure battery is disconnected. Unscrew and remove the grab handles from the A-pillar.

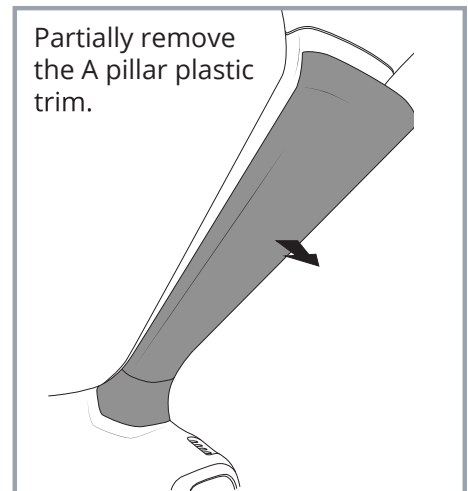
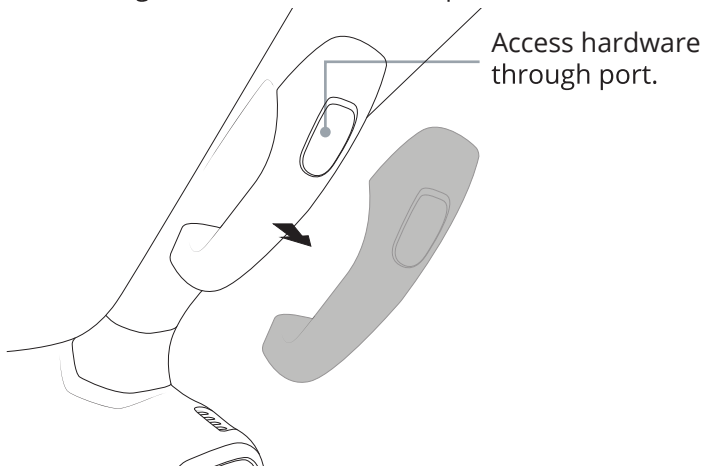

Partially remove the A pillar plastic trim.

3

Remove the cover from the sun visor and unscrew the two screws, pull the sun visor down gently until you can reach the connector and unplug.

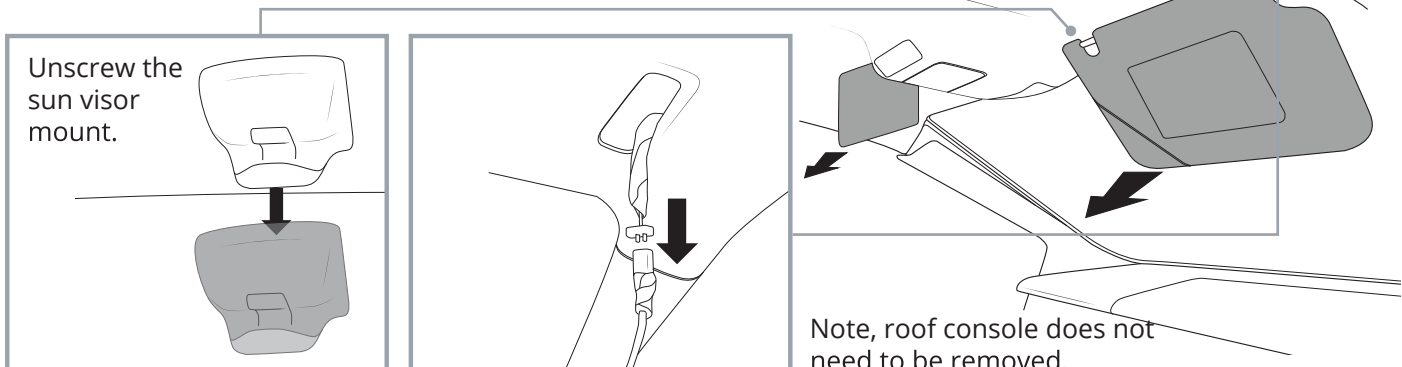

Unscrew the sun visor mount.

Note, roof console does not need to be removed.

4

Remove the top grab handle above the door.

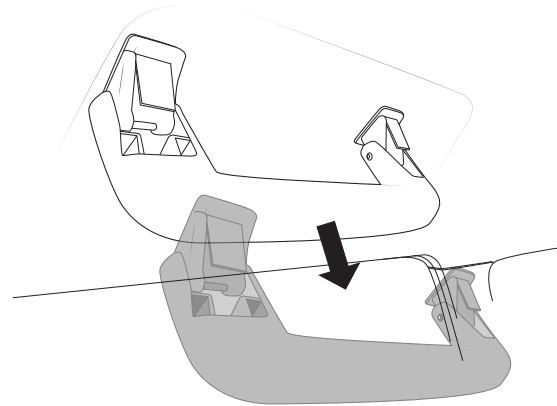

5

Unpeel the rubber door trim so that the top trims are exposed (approx. 50% from the top portion of the vehicle).

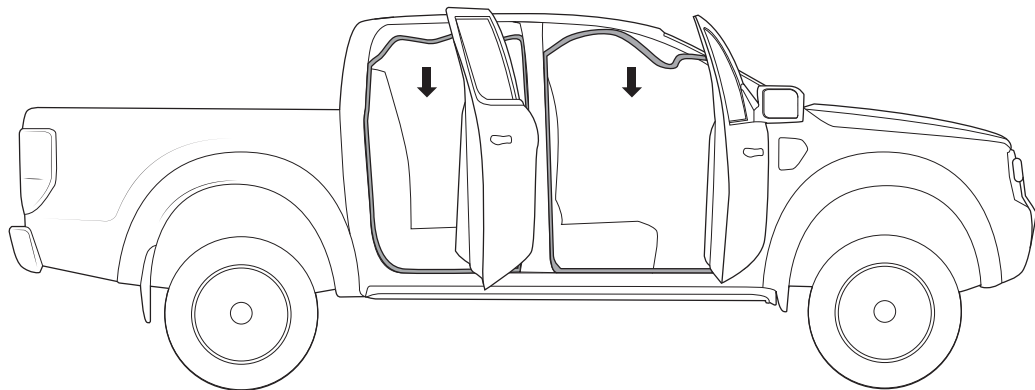

6

Move the seat back and recline for best access (don't do this if the seats are powered). Unscrew the seat belt (T50) torx.

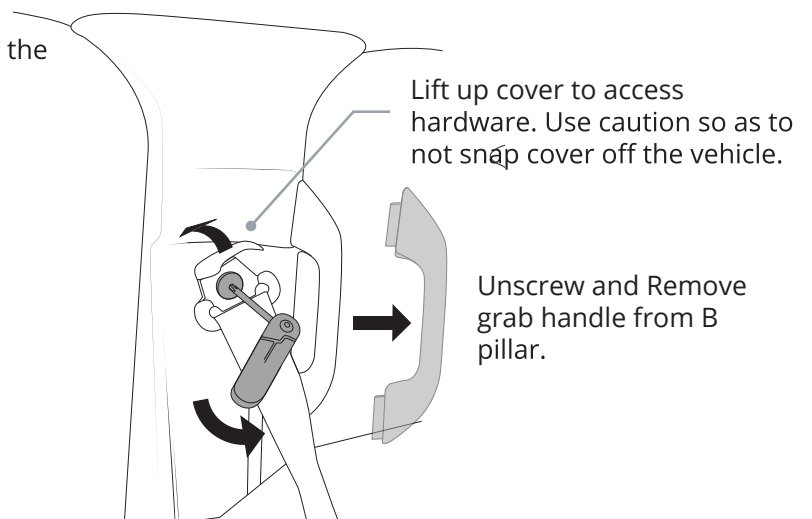

7

Grip the lower B pillar trim and gently pull it away from the wall. Gently remove the top B pillar trim making note of any clips that may fall off.

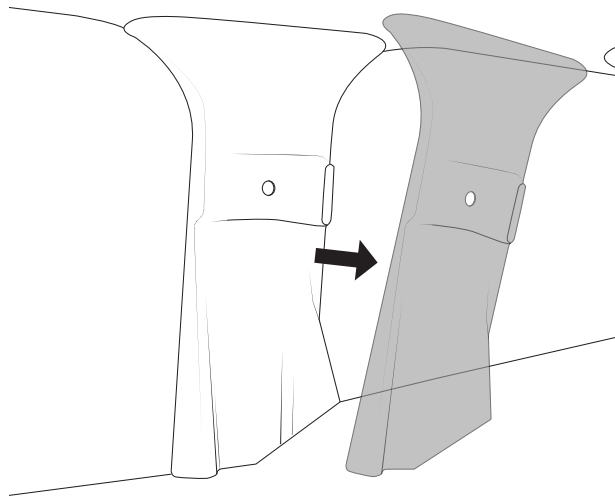

8

Unscrew and Remove grab handle from B pillar.

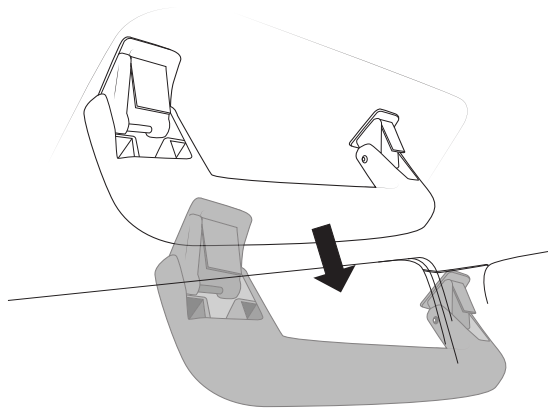

9

Pull the back seat to a forward position.

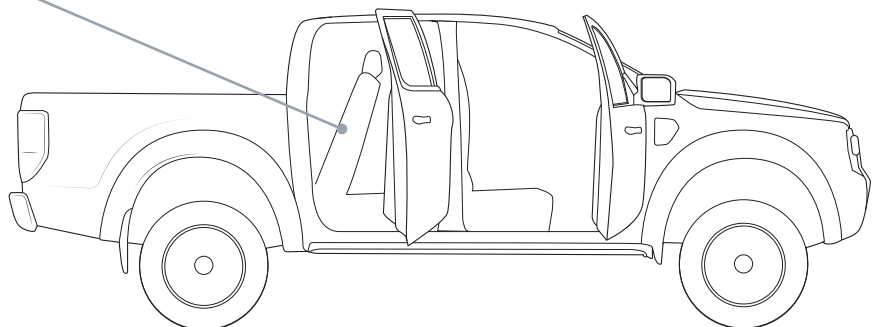
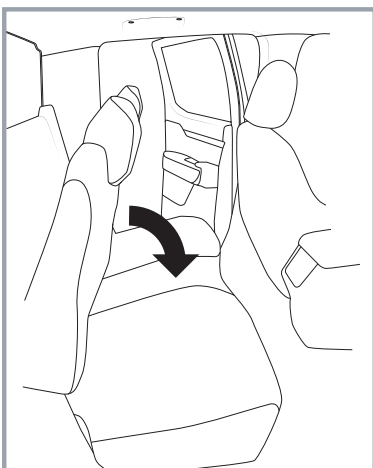

10

Remove the centre plastic cover plate from the rear seatbelt, behind the seat.

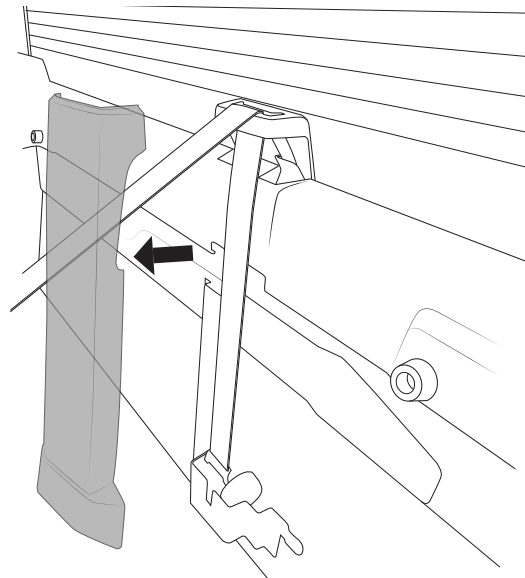

11

Remove the top plastic cover plate from the seatbelts, behind the rear seat.

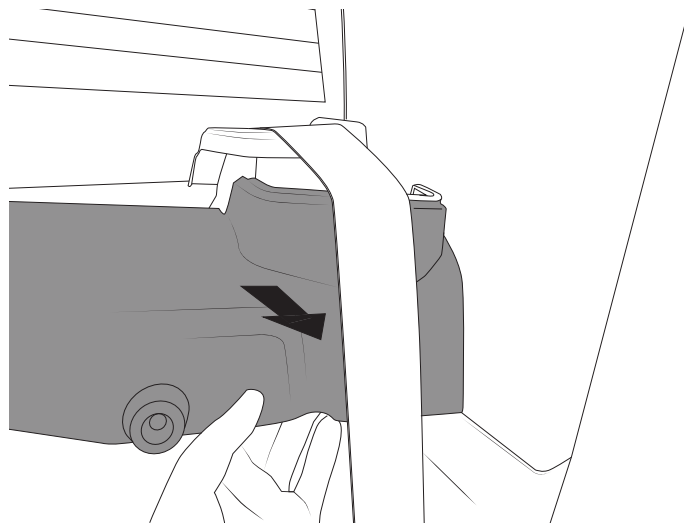

12

Remove the plastic panels from the side of the rear doors. They are held in place with clips, apply slightly increasing force until they pop free.

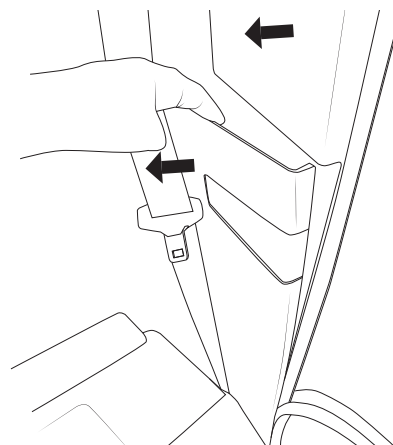

13

Using a flat blade screw driver, carefully pull the fastening latch down on the hooks in the roof.

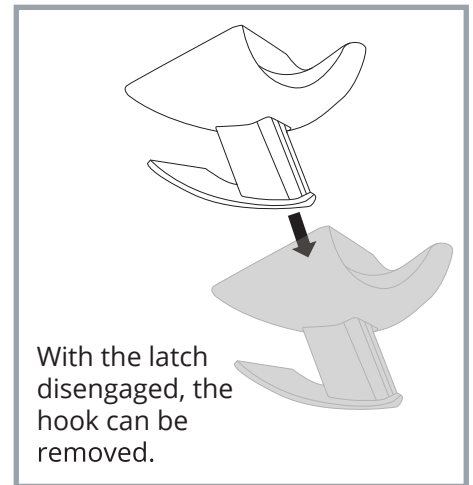
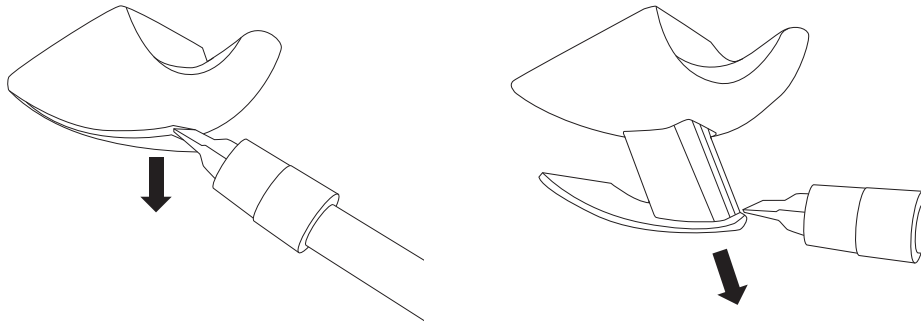

14

Once all the trims and screws have been removed, begin to gently pull down on the roof lining from the rear of the car, the roof lining is affixed by magnets and when you gently apply pressure it will disconnect and should provide enough access to the roof.

Note: the front of the roof lining will not lower, the camera and glasses box does not need to be removed for this task.

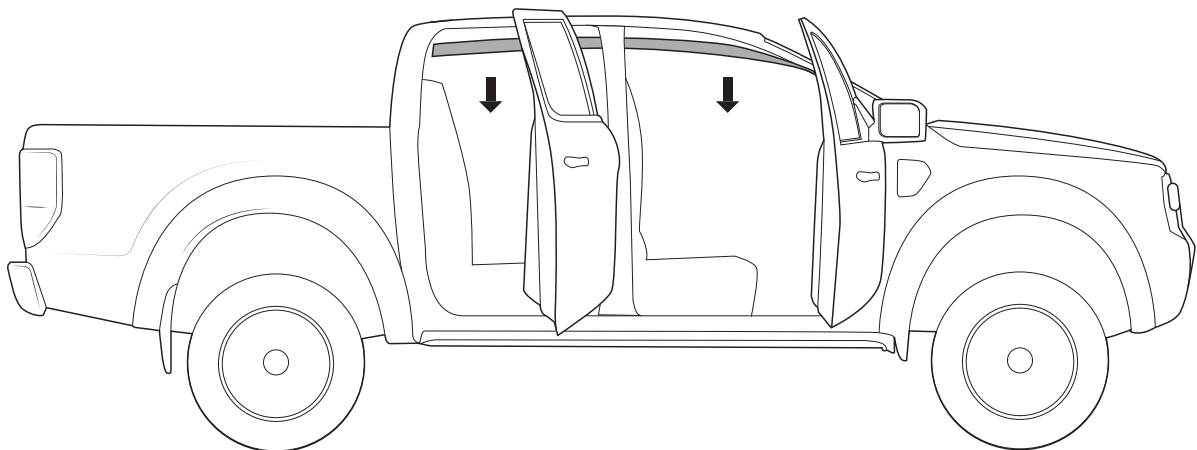

15

At the front and rear of the roof, with a trim tool, pry up the ditch fill and begin to lift. Do not try to completely remove the ditch fill at this stage. Lift only until the tooling mark on the fill as shown.

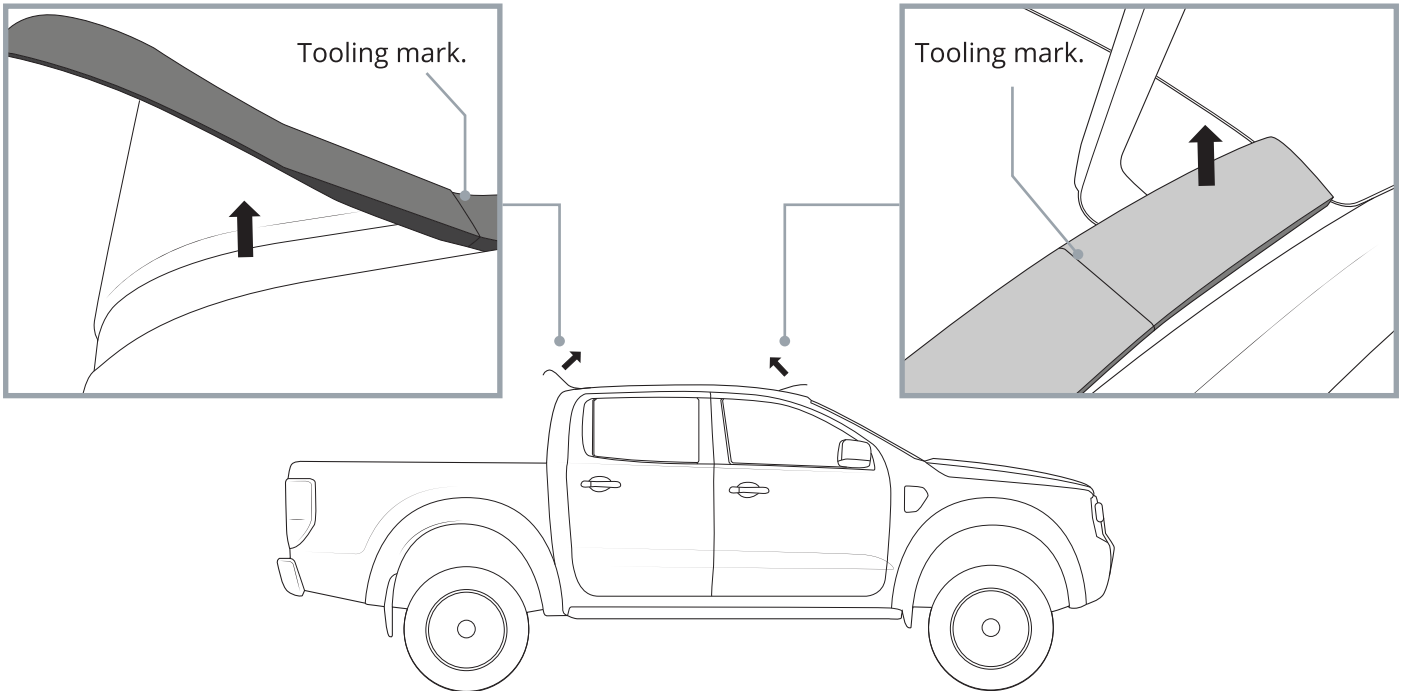

Note: The rubber fill is held in place by two studs, one at the front and one at the rear. Undo the 8mm nut or 15mm nut if equipped with raised rail. Carefully apply force to free the ditch fill.

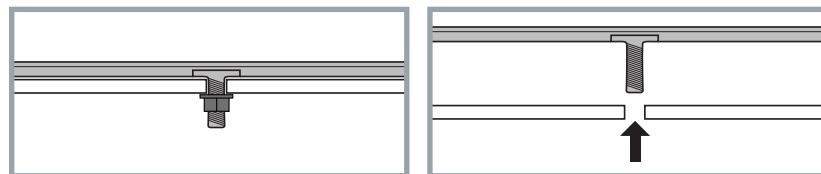

16

Measure towards the centre of the vehicle from these tooling marks and create a reference with a marker, at the dimensions shown.

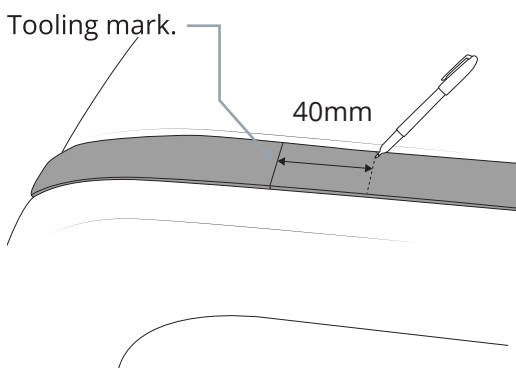

Rear of vehicle.

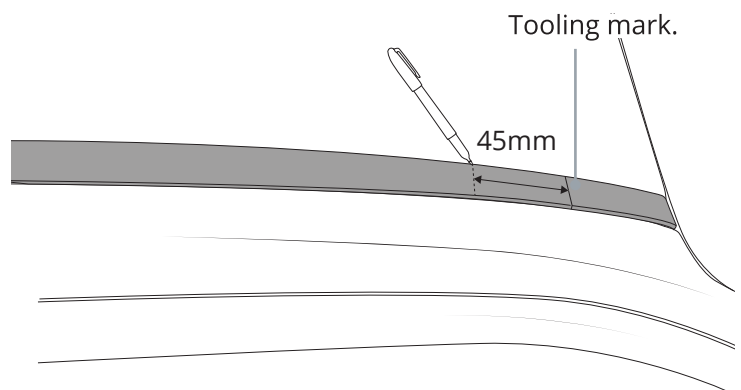

Front of vehicle.

17

Carefully cut the ditch fill at these reference points and remove the front and rear section of fill.

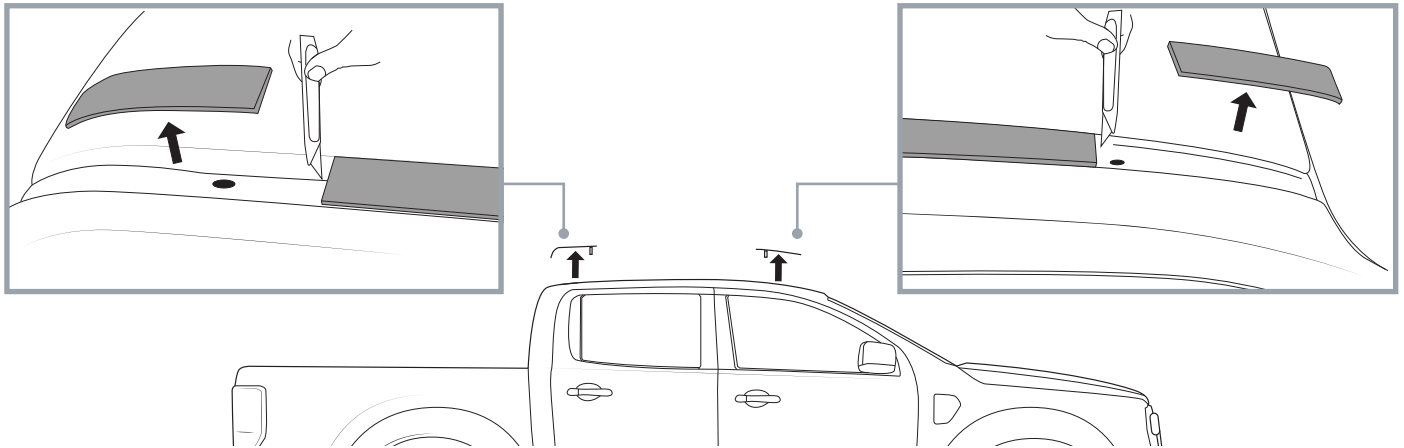

18

Clean the ditch where the fill has been removed.
 (A) Using butyl mastic, apply the sealant to all exposed holes in the roof.
 (B) Add **2x butyl** patches to these holes in the roof.

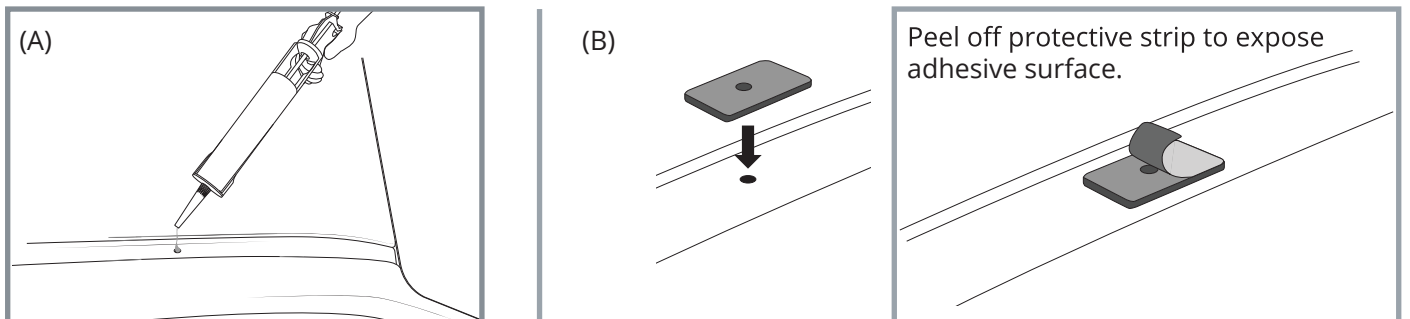

19

Assemble M6 hardware into the Ridge Mount Rails as shown.
 Note that the centre mount holes are used only.

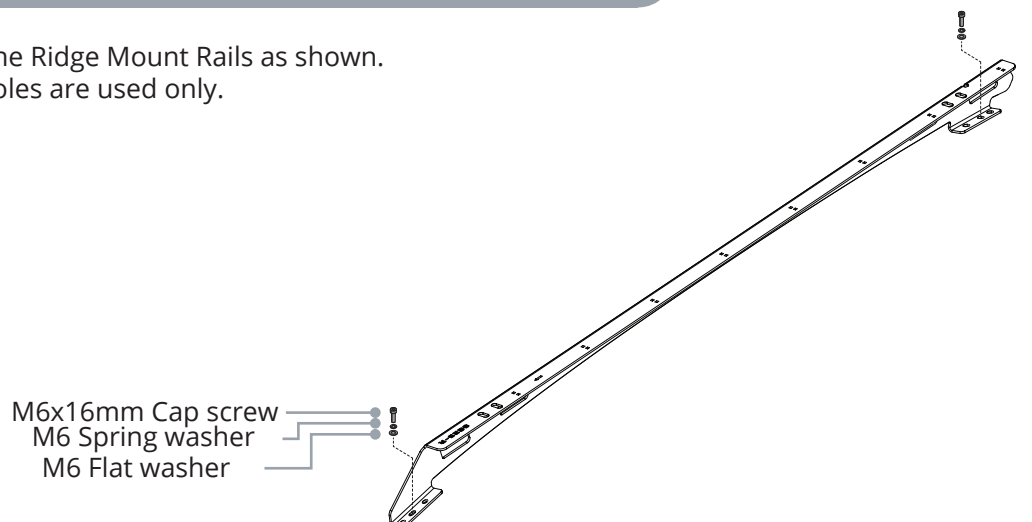

20

Install the stud plates as shown.

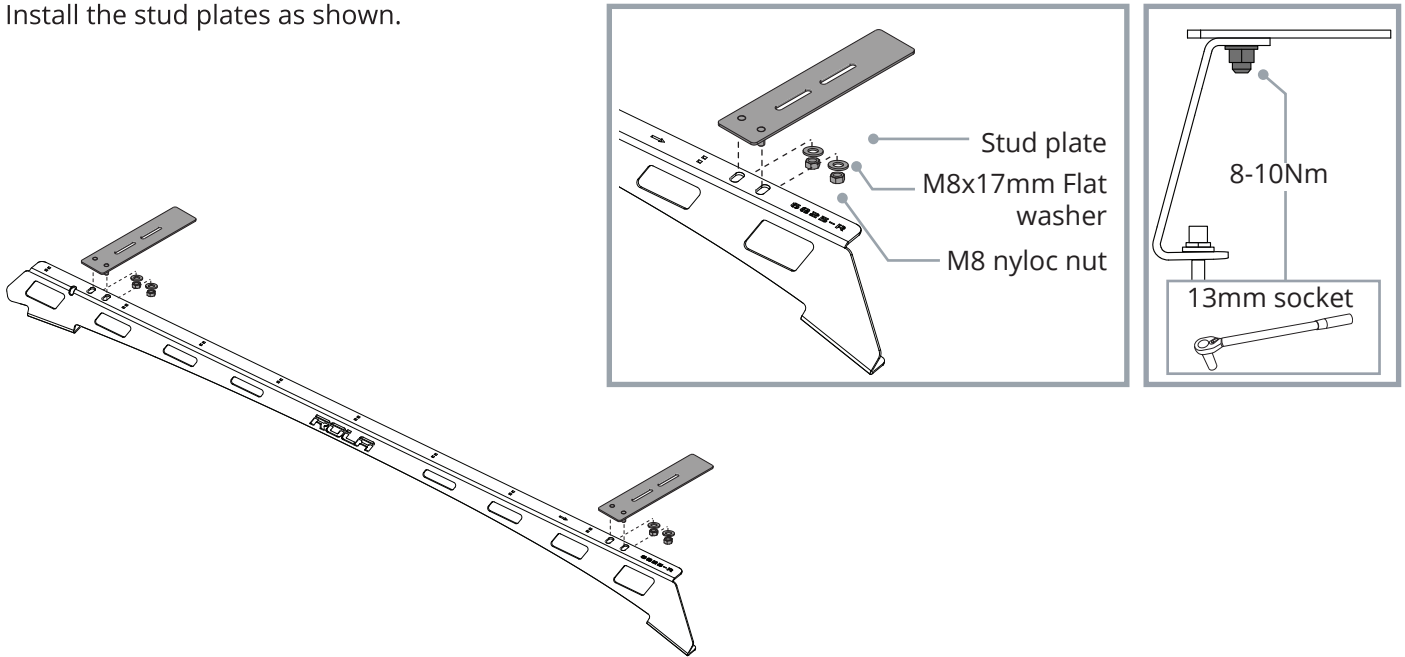

21

Place the Ridge Mount assemblies onto the roof. The M6 hardware will slide through the holes in the roof.

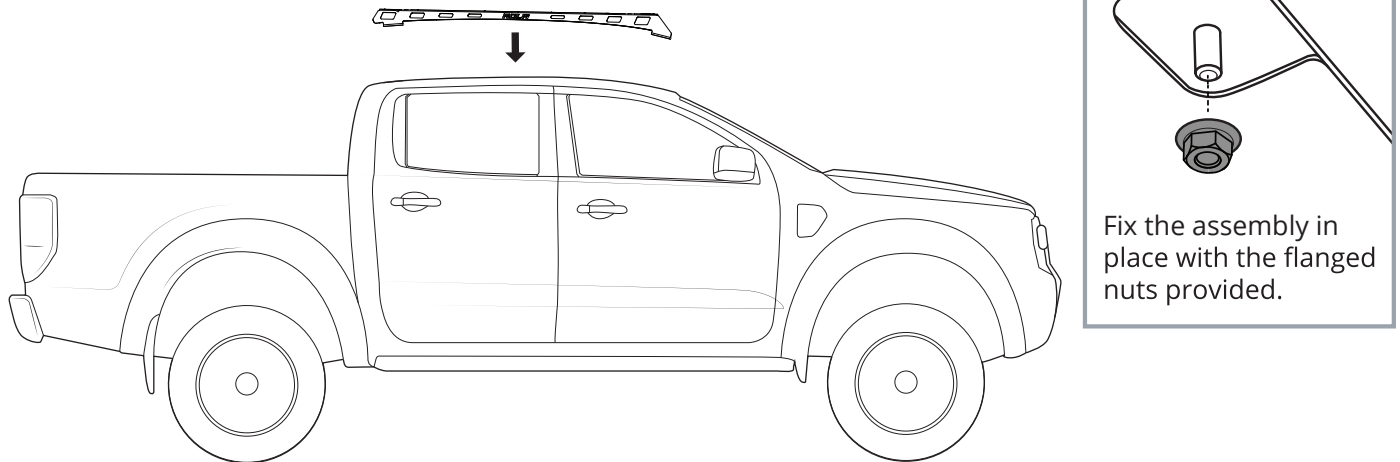

22

With the Ridge Mount fixed in place, the ditch fill removed in step 17 can be trimmed and replaced using 3M tape.

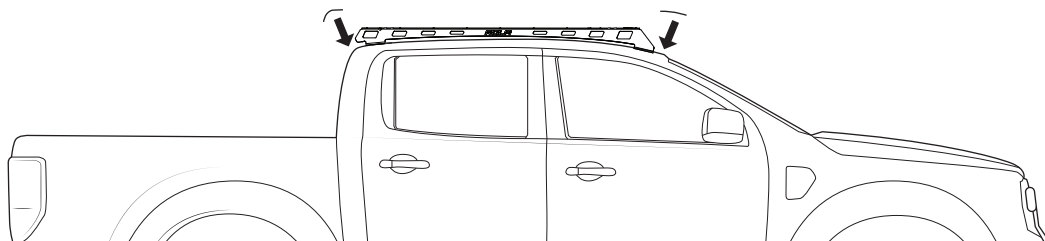

TITAN TRAY FITMENT

23

Install the Rola Titan Tray as per corresponding instructions.

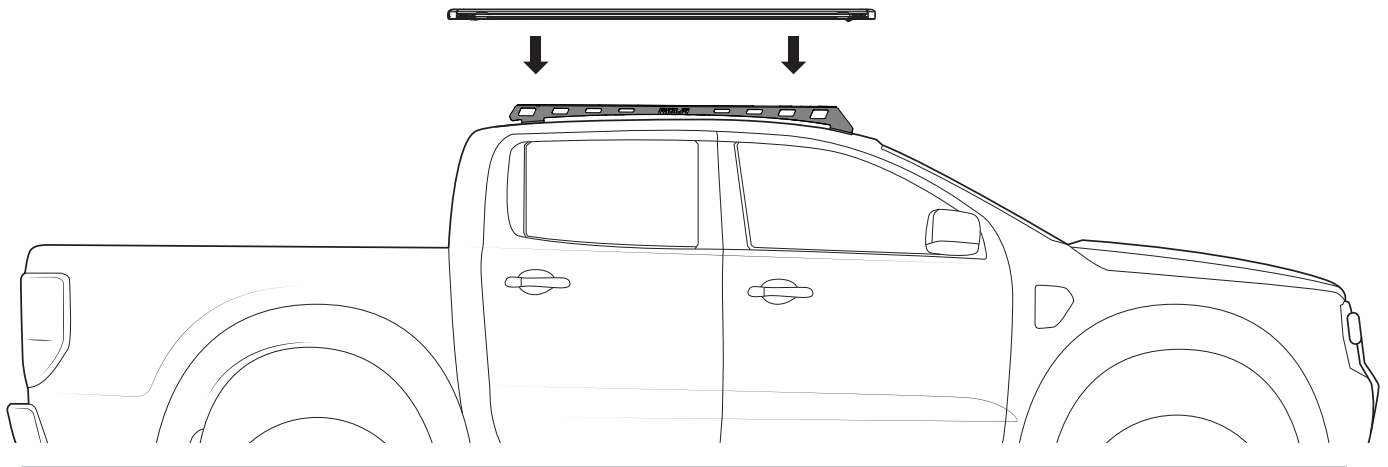
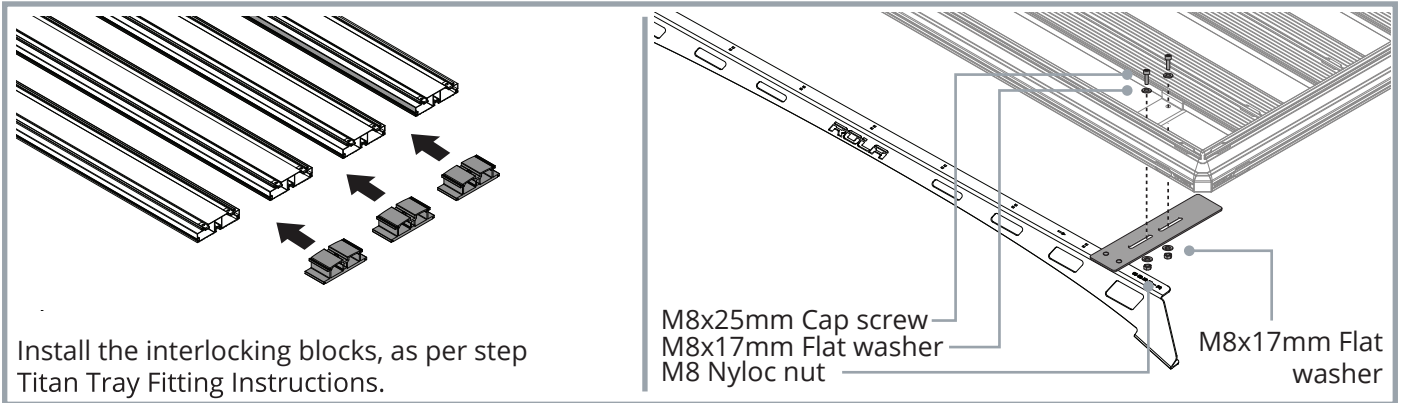

Note:

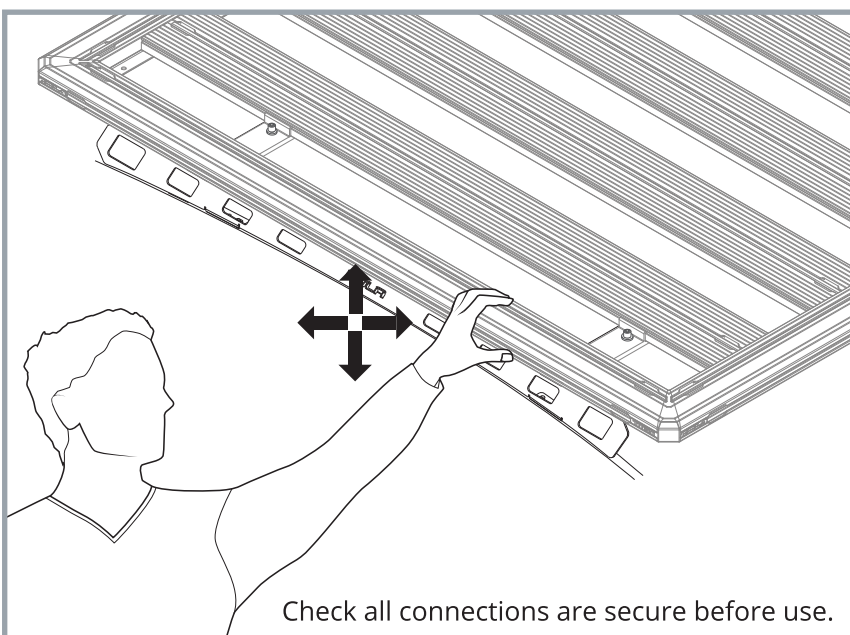

Wiring can be run and secured on the underside of the Ridge Mount rail as shown.

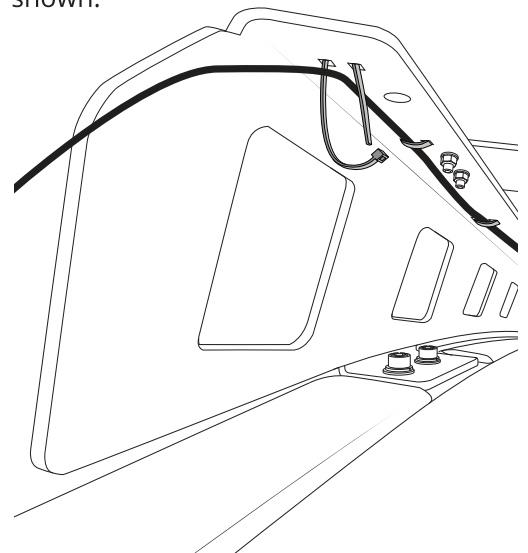

IMPORTANT - READ BEFORE USE

Please ensure the system is fitted in accordance with the fitting instructions. It is important that you observe all outlined below.

**LOAD RECOMMENDATIONS**

- Routinely and regularly check the proper functioning of the system. Check all fixtures at regular intervals.
- Do not use an automatic carwash with system installed.
- Maximum load capacity of the system is 400kg under static conditions.
- Maximum load capacity of the system is 100kg under dynamic including off-road conditions.
- Do not exceed vehicle manufacturers recommended load rating if it is lower than the maximum load capacity specified in this document (i.e., 100kg).
- Ensure any load carried is evenly distributed.
- Actual load on vehicle Roof (Refer to owner's manual) = Weight of Roof rack system / Ridge Mount + Weight of Tray + Weight of cargo.
- Actual load on rack system (Refer to product instructions) = Tray weight + cargo.

WARRANTY INFORMATION

Rola warrants that, subject to exclusions and limitations below, the Ridge Mount system will be free from defects in materials and workmanship for a period of 5 years commencing on the date of sale by the authorized Rola stockist to the original purchaser of the system.

If a defect appears in the Ridge Mount system before the end of the warranty period and Rola finds that the defect is in materials or workmanship, Rola will, in its sole discretion, either:

1. Repair the Ridge Mount or the defective component of the Ridge Mount system free of charge
2. Replace the Ridge Mounts or the defective component of the Ridge Mount system; or
3. Refund the purchase price of the Ridge Mount system to the original purchaser.

Rola reserves the right to change the design, specifications or composition of the Ridge Mount system without notice and without liability.

Rola reserves the right to replace defective products or components with products or components of similar quality, grade and composition, where an identical product or component is not available. Goods presented for repair may be replaced by refurbished goods of the same type rather than being repaired. Refurbished parts may be used to repair the goods.

The 5 year warranty does not apply where:

1. The Ridge Mount system is not installed in compliance with the fitting instructions provided
2. The Ridge Mount system is not used as intended or designed
3. Any part of the Ridge Mount system is used with other products or components not intended to be used in conjunction with the Ridge Mount system
4. The Ridge Mount system has been on-sold or assigned by the original purchaser
5. The Ridge Mount system has been modified or repaired by someone other than Rola or an authorized Rola stockist
6. Rola cannot establish any fault after inspection of returned product
7. The Ridge Mount system has been subject to abnormal conditions, including fire, water, humidity, pressure, stress or similar
8. The defect in the Ridge Mount system has arisen due to abuse, misuse, neglect or accident
9. The defect in the Ridge Mount system has arisen due to the unlawful or unusual operation of the vehicle to which it is fitted
10. The defect in the Ridge Mount system has arisen due to the purchaser's failure to properly assemble, install, fit, maintain or use the Ridge Mount system in accordance with the specifications and instructions provided by Rola.

For safety and use instructions, please refer to any General or Specific Fitting Instructions and Warning & Care Instructions enclosed within the Ridge Mount system or on our website at www.rola.com.au.

This warranty does not extend to fair wear and tear. Warranty claims can be made by contacting Rola directly using the details below. A warranty claim must be accompanied by proof of purchase (such as receipt), details of the alleged defect and appropriate documentation (such as historical and maintenance records where appropriate). The customer must make the product available to Rola or its authorized repair agent for inspection and testing. If such inspection and testing finds no defect in the product, the customer must pay Rola usual costs of service work and testing. It is the purchaser's responsibility to arrange and pay to return the product or component to the place of purchase. The purchaser may seek reimbursement from Rola for the cost of such activities, providing Rola notifies the purchaser in writing that a warranty claim is justified. Any such claims made must be in writing via post or email.

The benefits of this warranty are in addition to any rights and remedies imposed by Australian State and Federal legislation that cannot be executed. Nothing in this warranty is to be interpreted as excluding, restricting or modifying any State or Federal legislation applicable to the supply of goods and services which cannot be so excluded, restricted or modified. Our goods come with guarantees that cannot be excluded under the Australian Consumer Law. You are entitled to a replacement or refund for a major failure and for compensation for any other reasonably foreseeable loss or damage. You are also entitled to have the goods repaired or replaced if the goods fail to be of acceptable quality and the failure does not amount to a major failure. Rola makes no express warranties or representations other than set out in this warranty.