

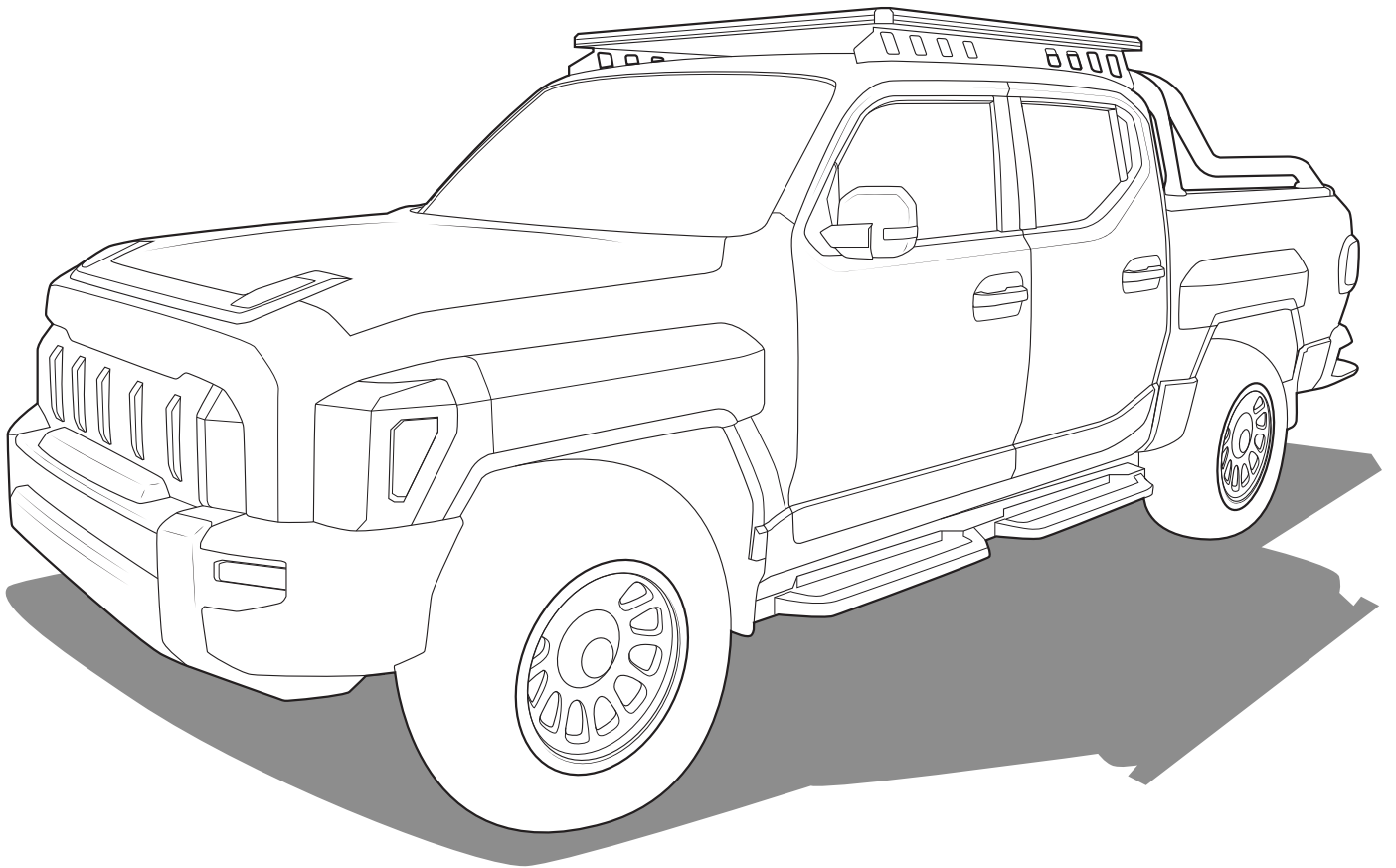









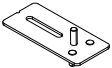
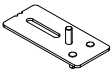
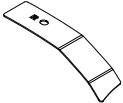

RIDGE MOUNT

by **ROLA**[®]



CONTENT - CHECK ALL PARTS ARE CORRECT BEFORE PROCEEDING

A		Ridge Mount (pair)	1
B		Stud Plate Front	2
C		Stud Plate Rear	2
D		Right Cover	1
E		Left Cover	1
F		M8 x 25mm Cap Screw	4
G		M8 Washer	20
H		M8 Nyloc Nut	16
I		Spacer	12
J		Large Washer	24
K		M6 x 30mm Cap Screw	12
L		Butyl Patch	12
M		M6 Nyloc Nut	12

TOOLS REQUIRED

- Socket set.
- Phillips & Flat head screwdriver.
- Trim tools.
- Power drill.
- 2,5,5.5mm drill bit.
- Cold gal.
- Vacuum.
- Allen Keys.
- Cutter.

1

Gain access to the passenger side of the vehicle.
Note: S,SX and SX+ shown.

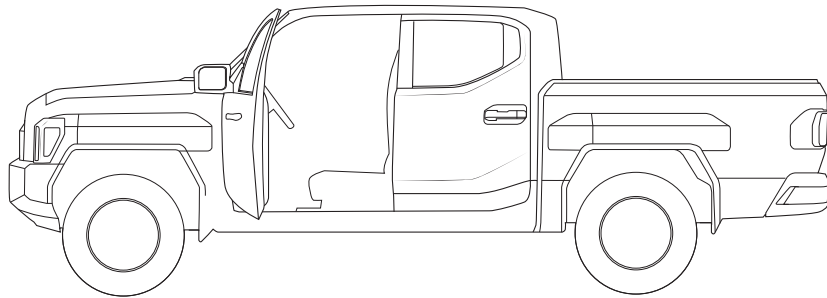

X-Line models will have factory rails.

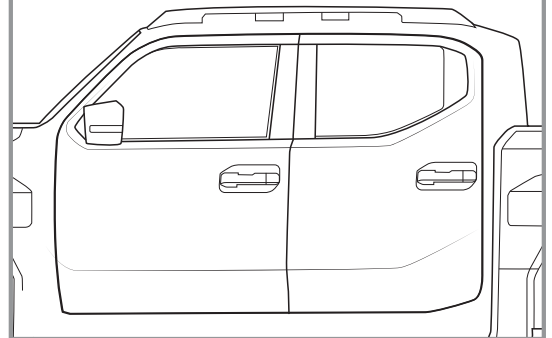

2

Remove the A pillar grab handle. Pry off the two covers and undo using 10mm socket.

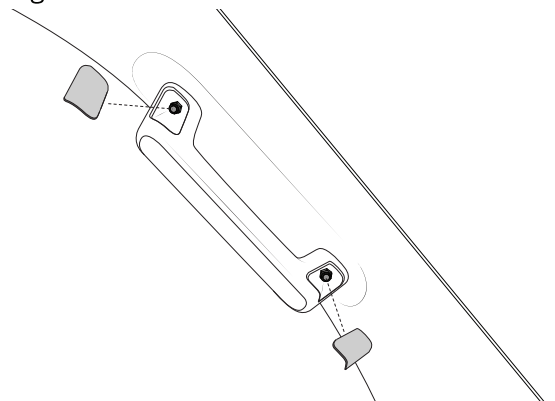

3

Remove the upper grab handle by prying off the covers and release two Phillips head screws.

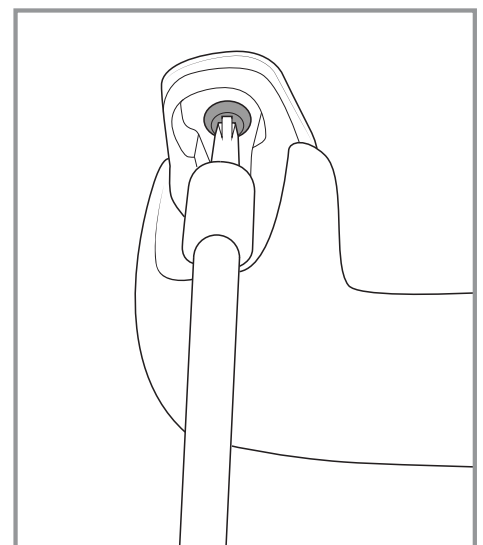

4

Gain access to the window visor, remove the sun visor bracket by releasing Phillips head screw, then by prying at the indicated holes on each side of the bracket. Pull down and the bracket will release.

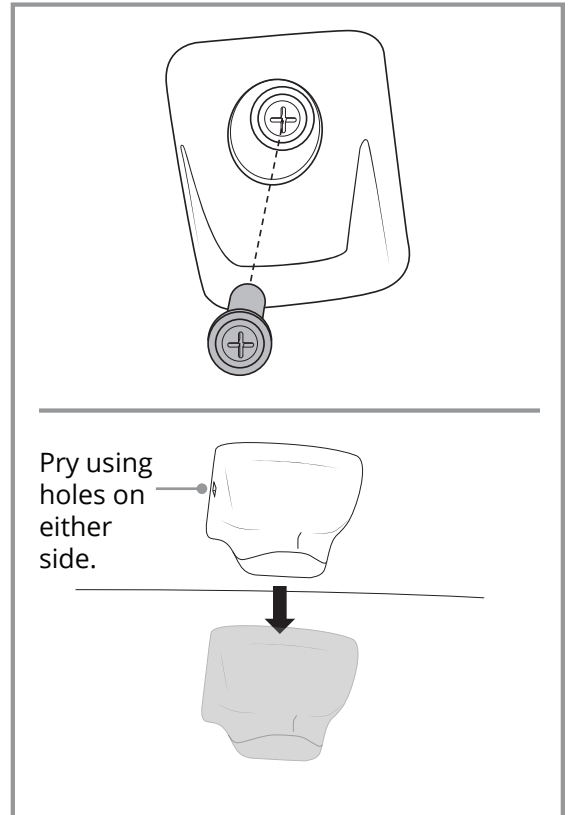
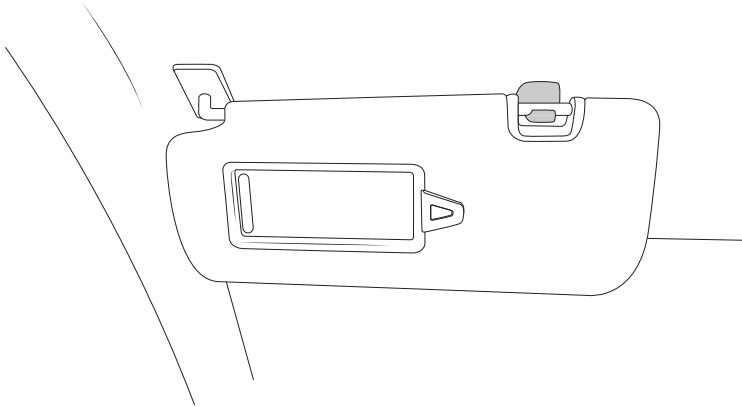

5

Release the sun visor bracket cover then move the visor to the side and extend it out then unscrew the Phillips head screws.

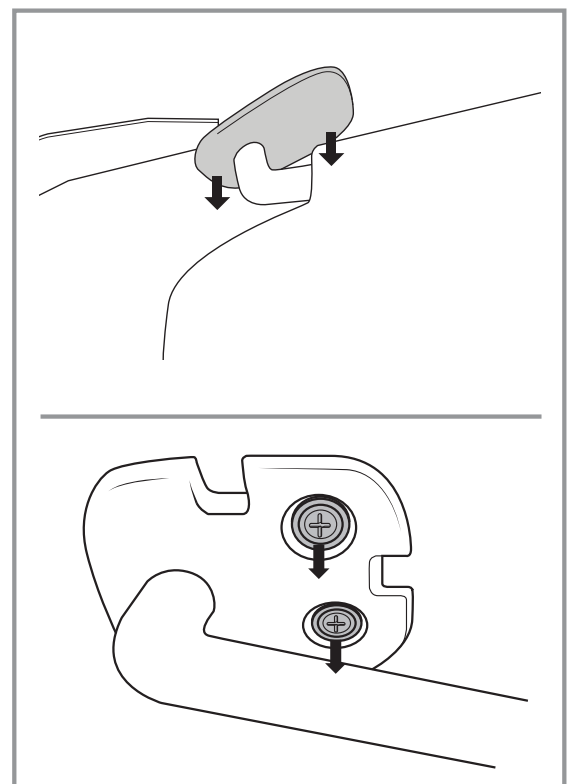
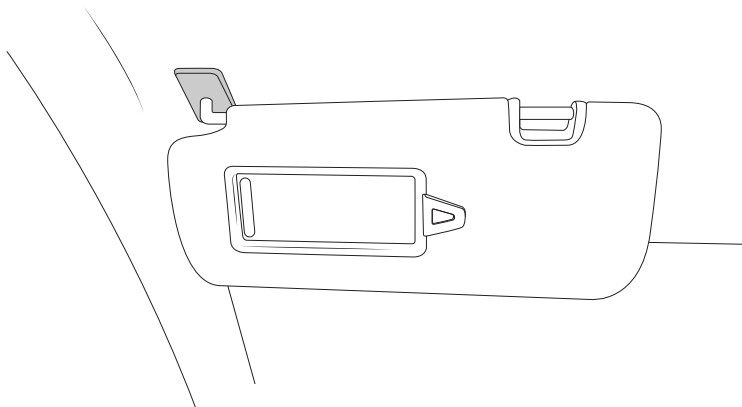

6

Pry off the sun visor light and disconnect the connector.

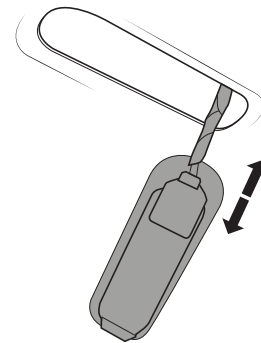
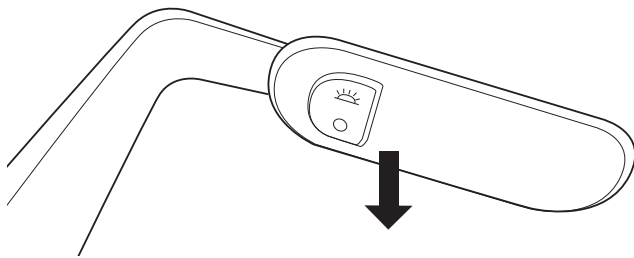

7

Release the passenger door seal.

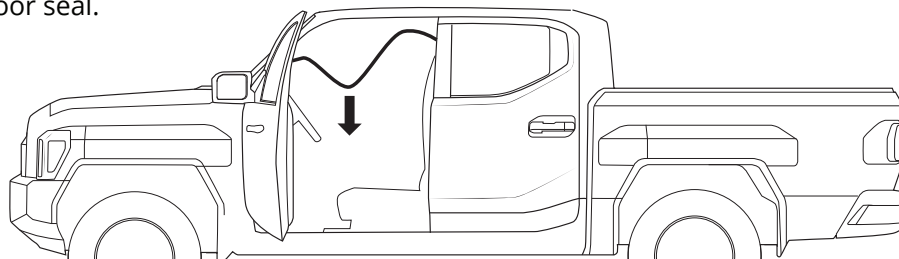

8

Pry off the A-pillar cover. There are two clips holding it in place. A trim tool may be needed for the upper clip.

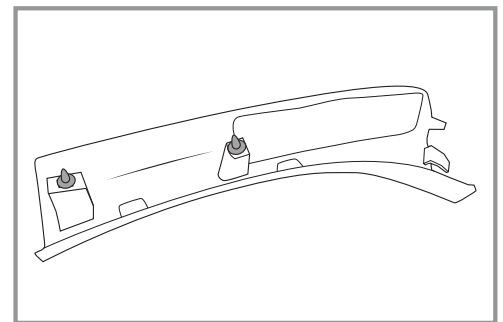
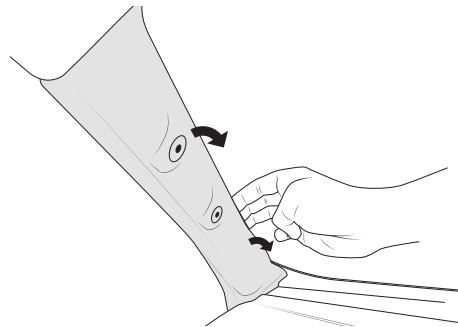

9

Pry off the centre console cover, undoing the clips on both sides. Use a trim tool around the lip of the console to dislodge the clips. Remove the unit, disconnecting its wiring loom.

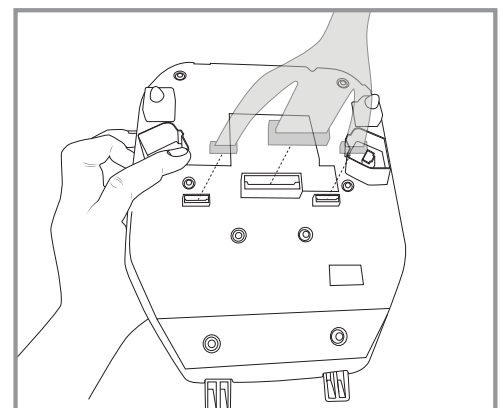
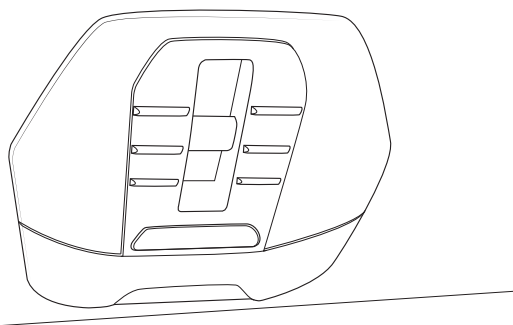

10

Moving to the passenger rear, remove the upper ceiling handle but prying the covers and releasing the two Phillips head screws.

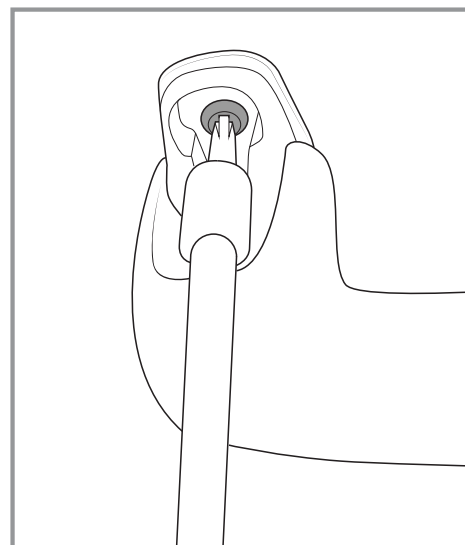
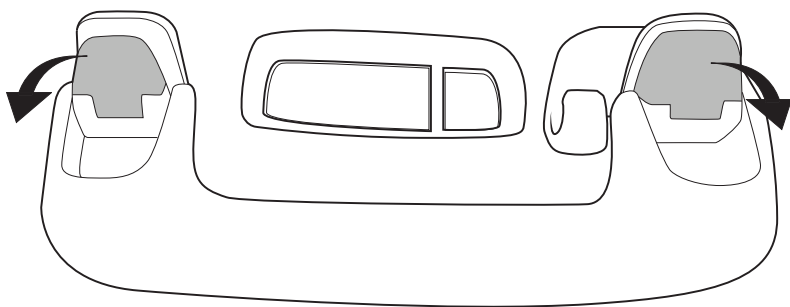

11

Pry the light off and disconnect the harness by using a screwdriver the release from the pins.

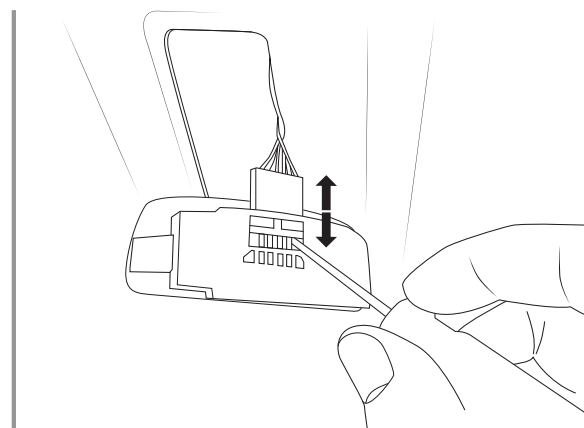
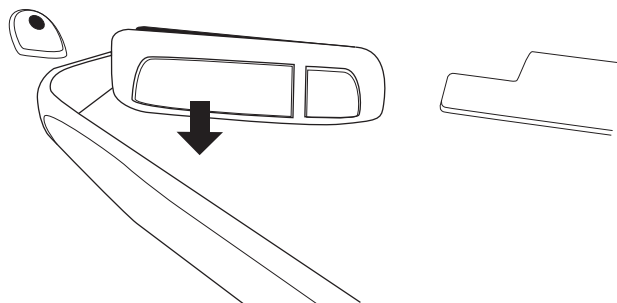

12

Release the B-pillar handle by releasing the covers and undoing the 10mm fasteners.

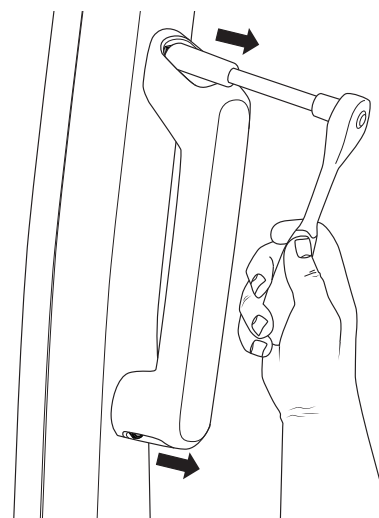
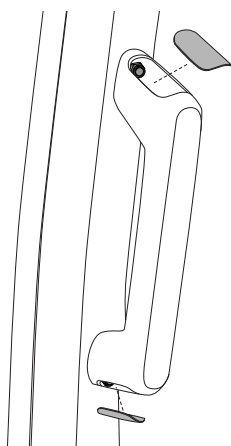

13

Release the rear passenger door seal.

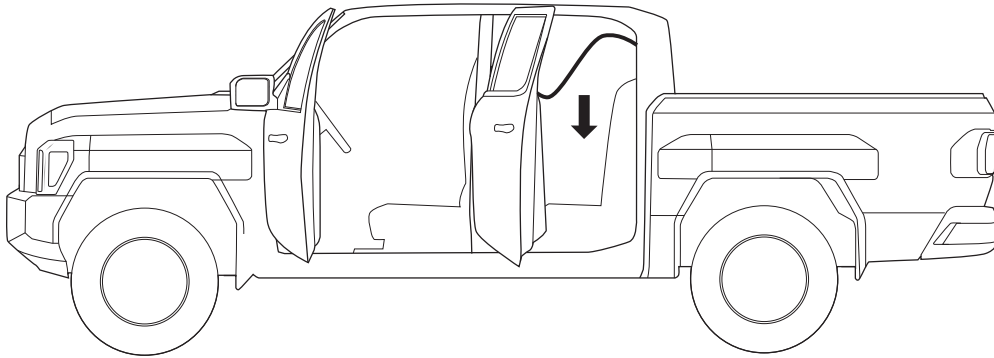

14

To remove the upper B-pillar trim, first release the airbag cover and undo the 10mm fastener.

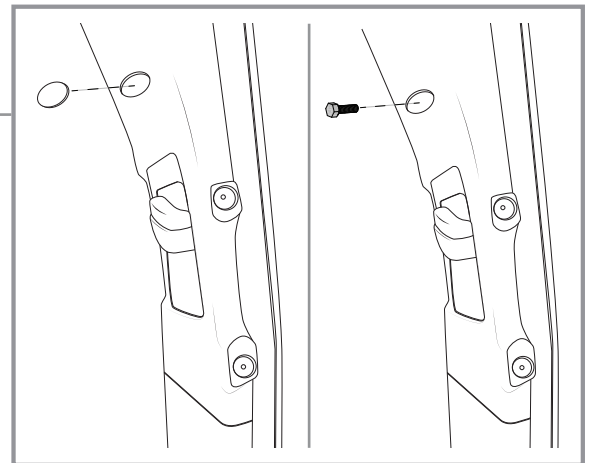
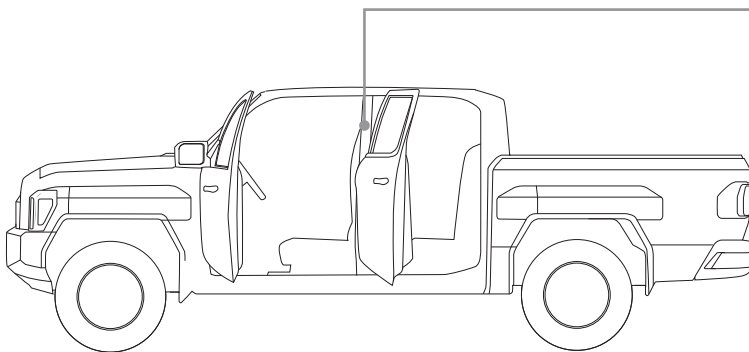

15

Release the lower B-pillar trim by prying from the sides, there will be two clips to remove.

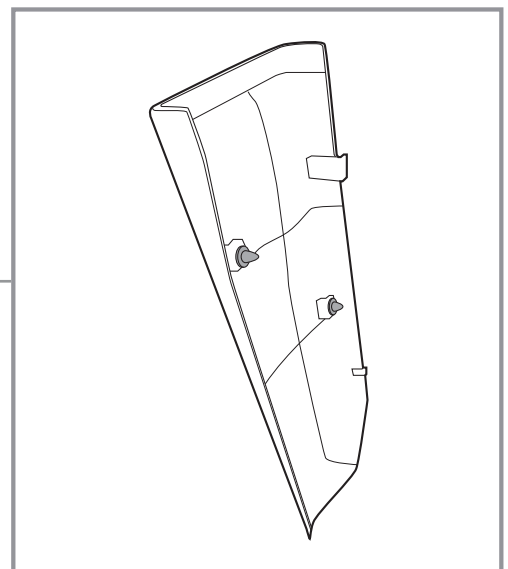
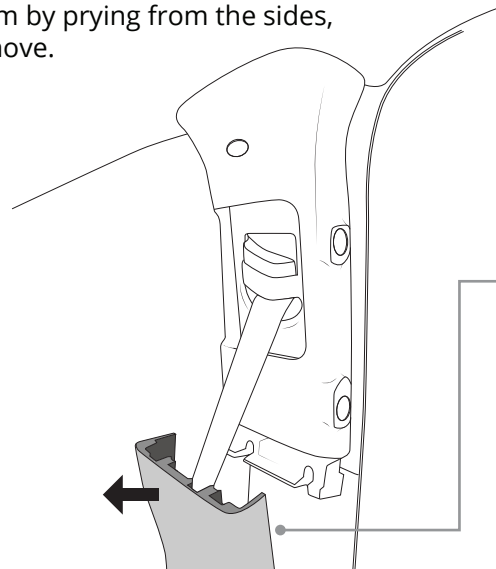

16

Release the upper B-pillar trim lower clips that side behind the lower B-pillar trim, then release a clip at the top of the upper B-pillar trim.

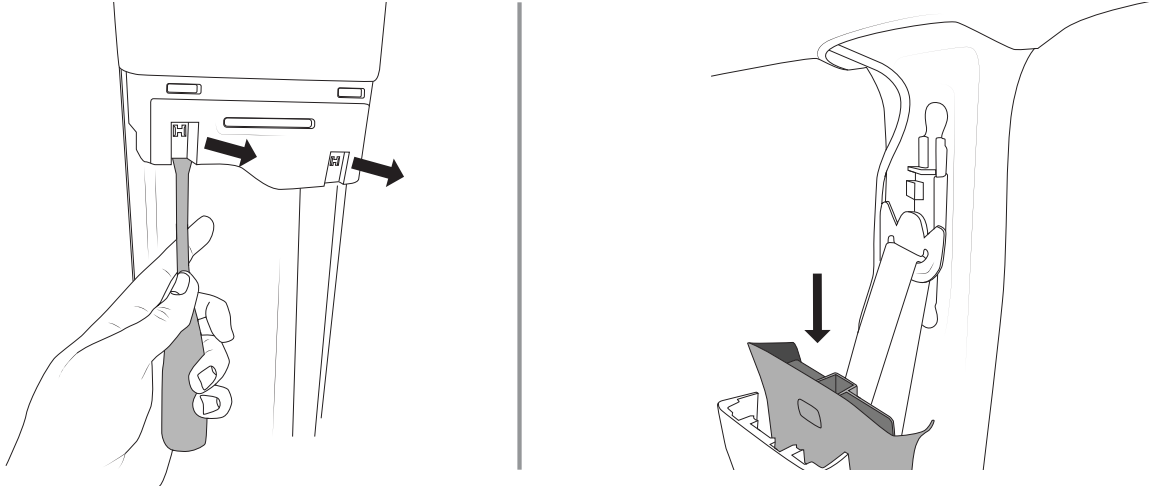

17

Fold the rear seats down to get access to the C-pillar trims.

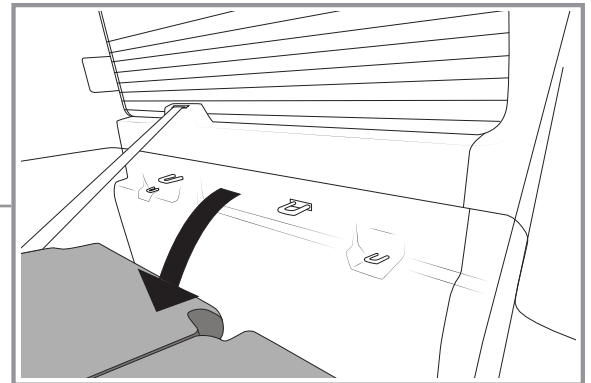
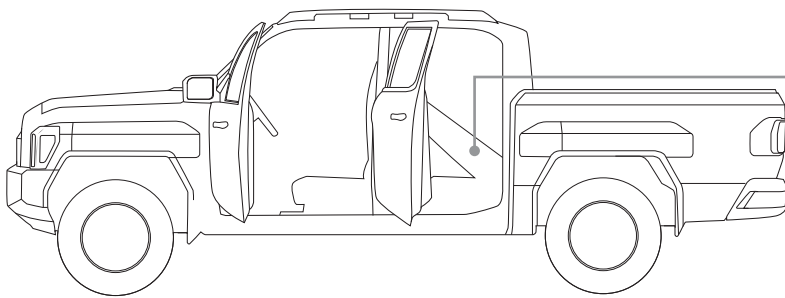

18

Partially release the lower C-pillar trim by prying the clips out.

NOTE: The trim will only release until the curve of the bodywork as shown, but this will give enough access for the upper C-pillar trim. Complete removal of this trim is not required.

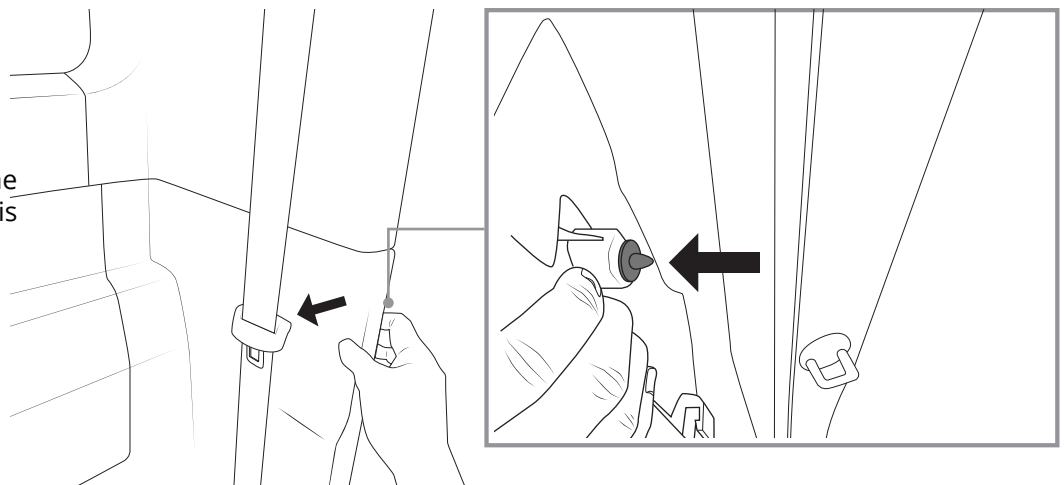

19

To release the upper C-pillar trim, first pry off the cover which will reveal access to two clips above and below, remove them.

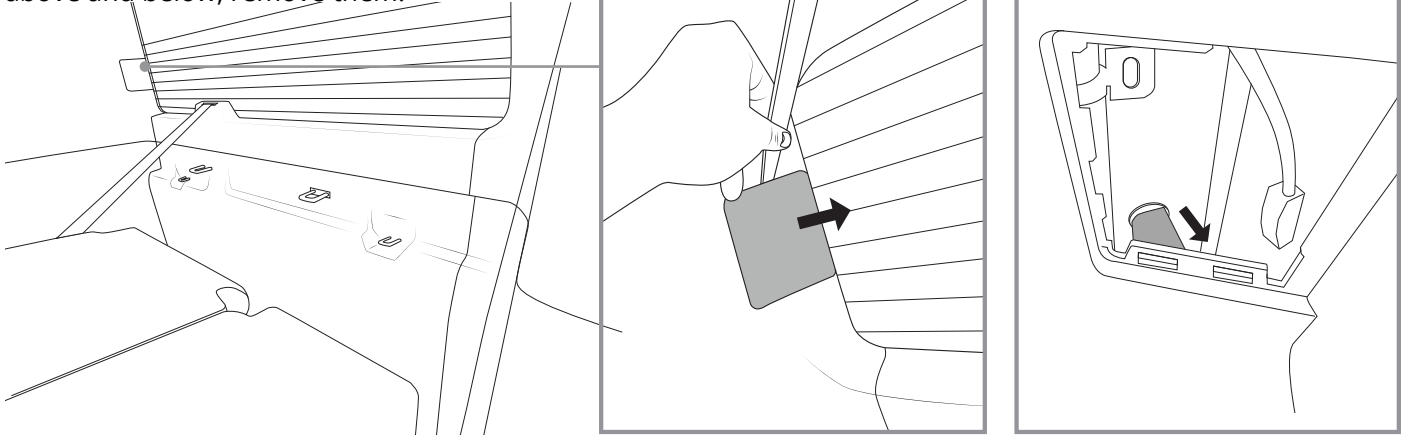

20

Remove the 10mm fastener at the bottom of the upper C-pillar trim.

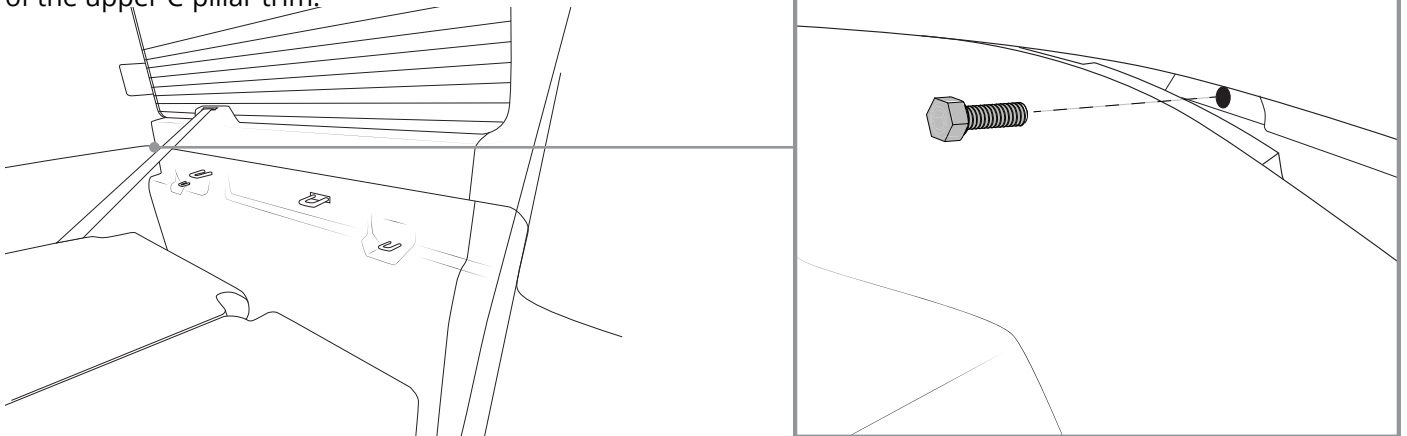

21

Remove the remaining clips of the C-pillar. Repeat previous steps for the drivers side of the vehicle.

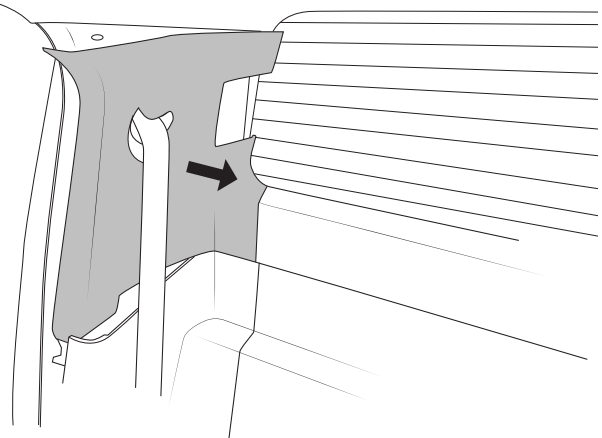

NOTE

The plastic tree plugs above the rear window, can be removed to assist in roof trim removal. However this will require replacement plugs, as they break on removal. This is not required to complete the fit.

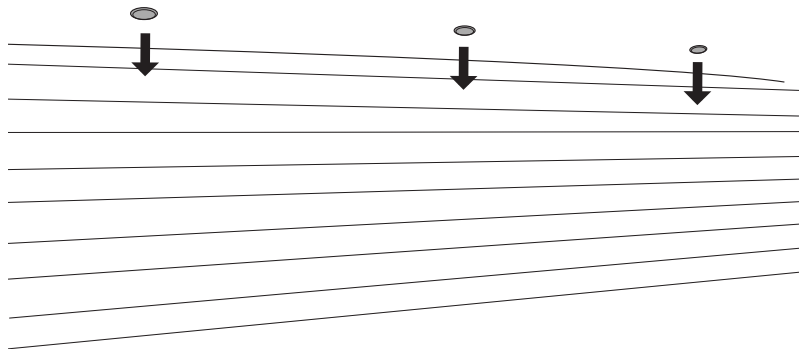

22

Release the velcro holding the roof liner to the vehicle and allow it to rest.

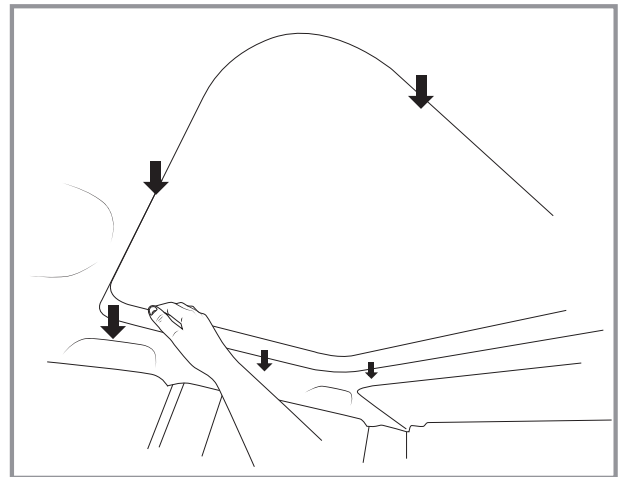
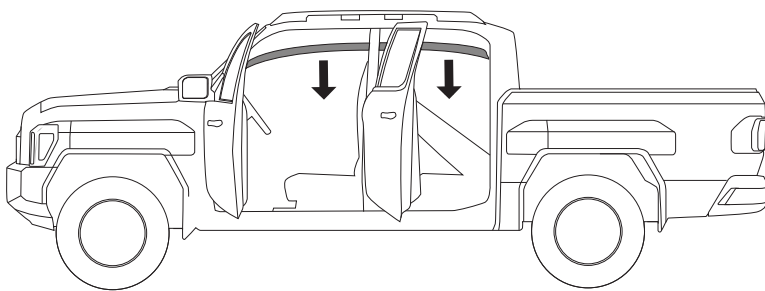

NOTE: X-Line models only - For S, SX and SX+, move to step 27

23

Release the newly exposed 10mm fasteners, holding the factory rail in place.

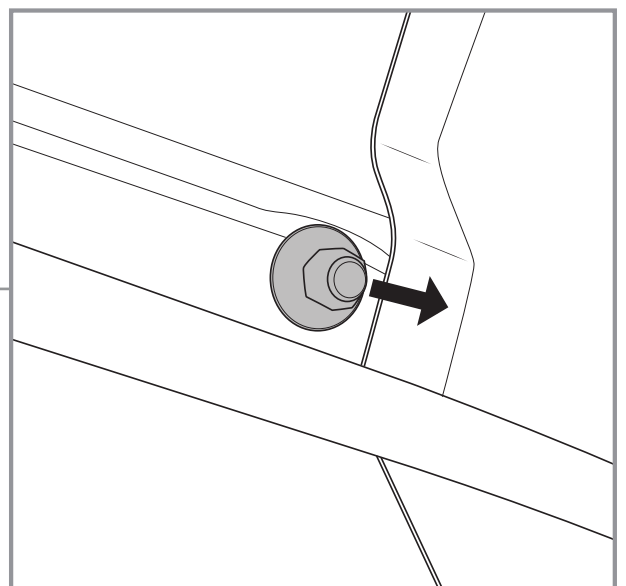
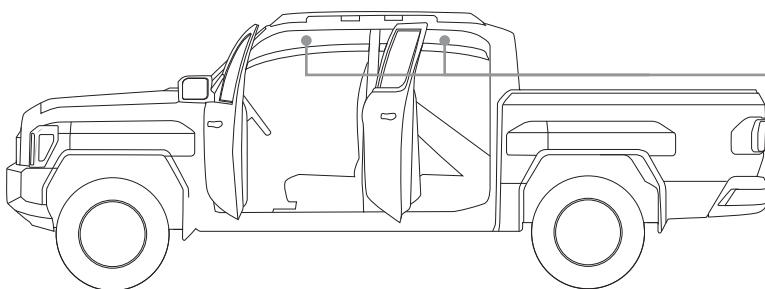

24

Remove the factory rail, you may need to pry from the ends as there is a sealant holding it in as well.

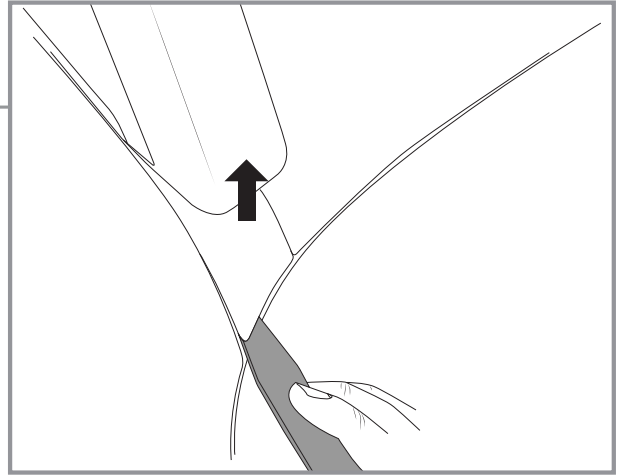
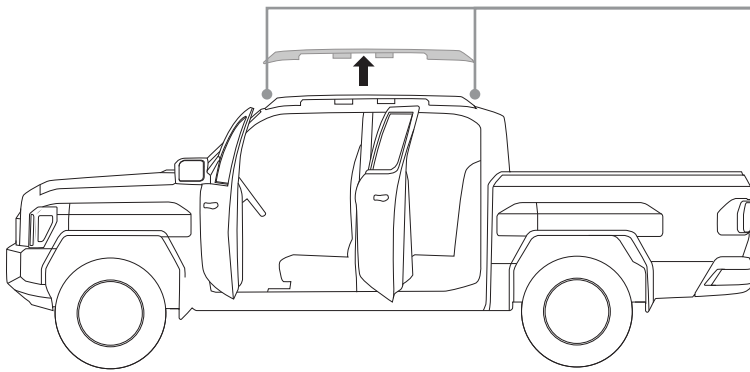

25

A) Remove the gutter cover at the rear of the factory rail.
 B) Carefully cut the cover at the point where it meets rail as shown.

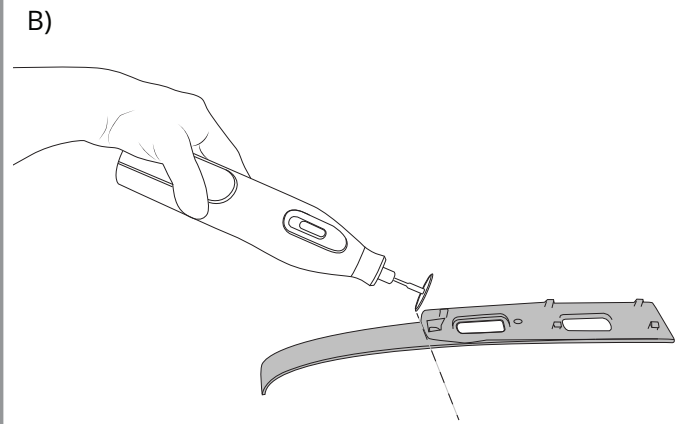
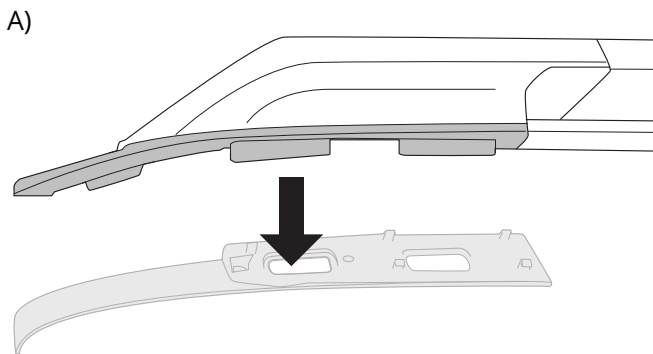

NOTE: Move to step 30 when complete

26

Reinstall the cut section of the factory trim to the vehicle. This will clip into place on the factory clip locations.

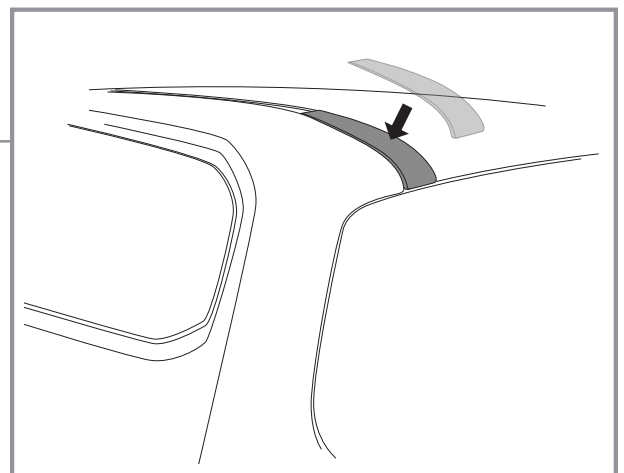
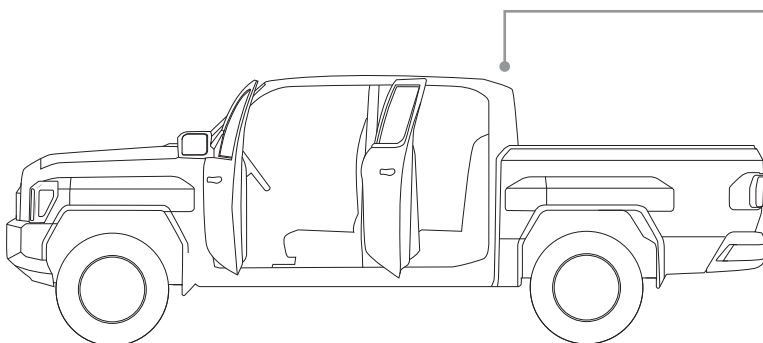

27

For S, SX & SX+ undo the 10mm fastener at the front of the vehicle and then release the clips for the factory gutter trim.

NOTE: This trim can be cut and used for the front and rear of the Ridge Mount.

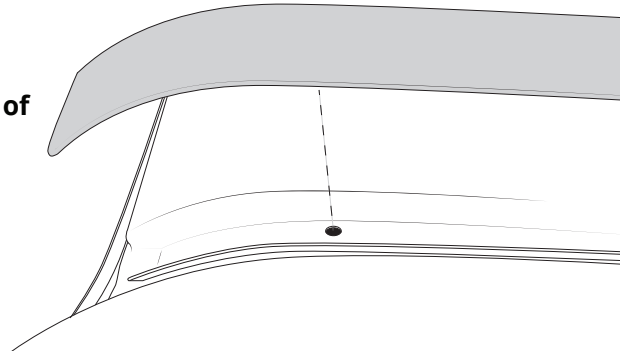

28

Measure back from the newly exposed hole at the front of the vehicle, using the dimensions shown. Using a marker, create a reference, centred in the gutter at these points.

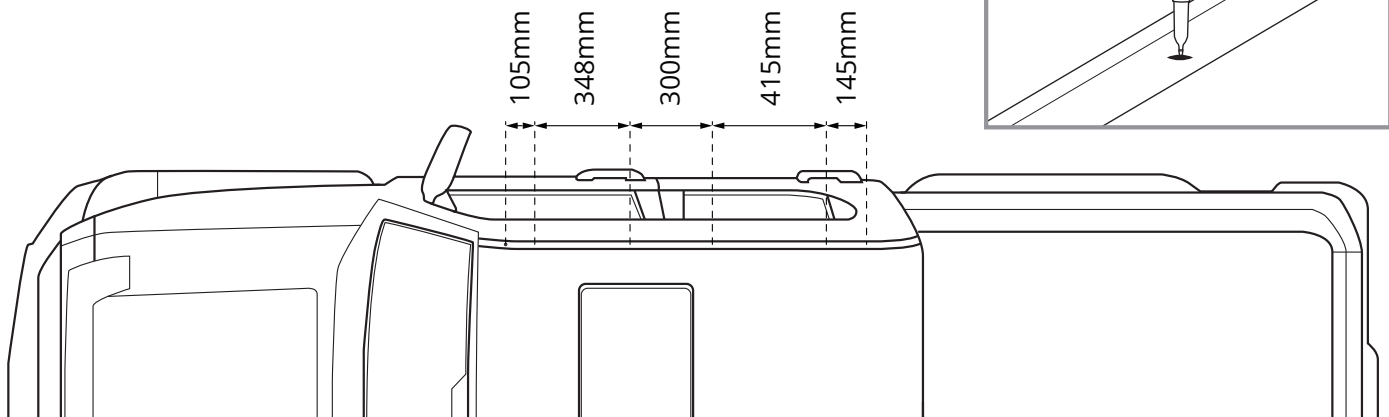
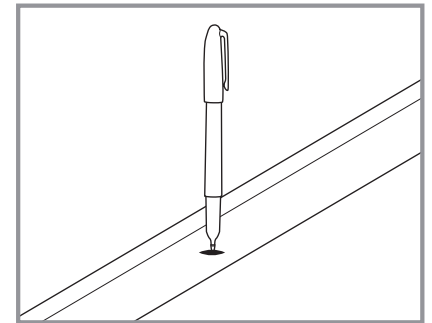

29

Centre punch the gutter at these points. Using a power drill and 2mm but, pilot mark these references. Open these pilot holes first with a 5mm bit, then a 6.5mm bit. Vacuum any swarf from the roof.

Apply cold galvanising paint to all holes drilled.

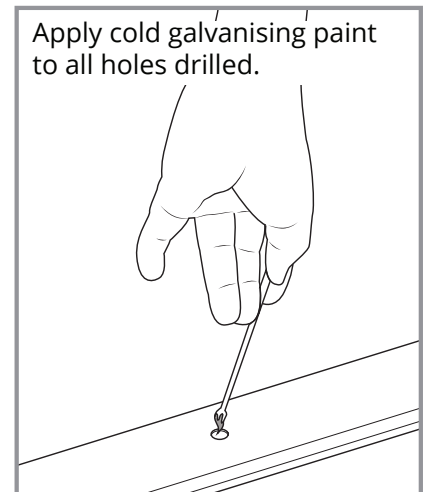
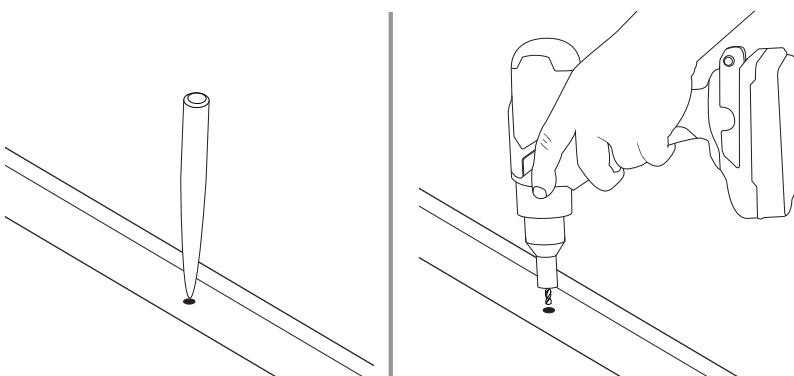

30

Place a butyl patch over each of the 6 cavities per side. Finally place a spacer over the top of the installed patch.

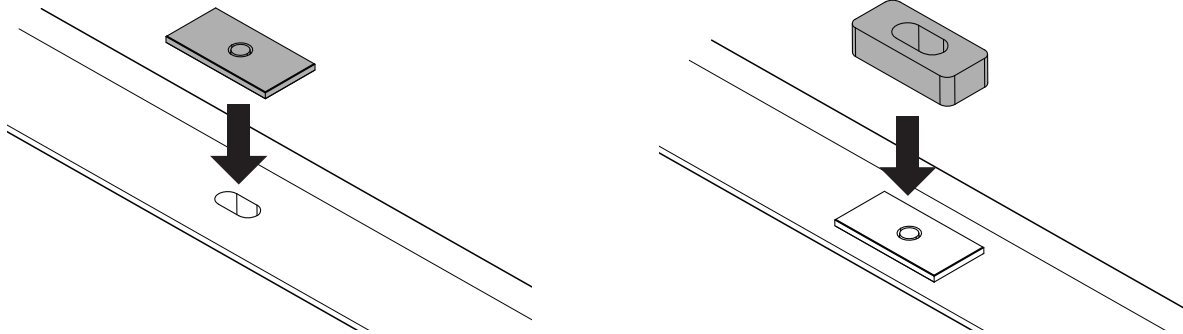

31

Fit the supplied front covers to the roof gutter. Align the hole in the cover to the first slot in the roof. These are labeled left and right.

NOTE: The factory trim can be cut and used instead if preferred.

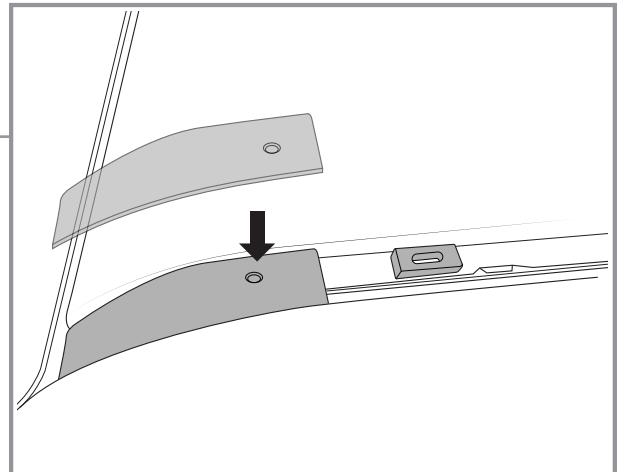
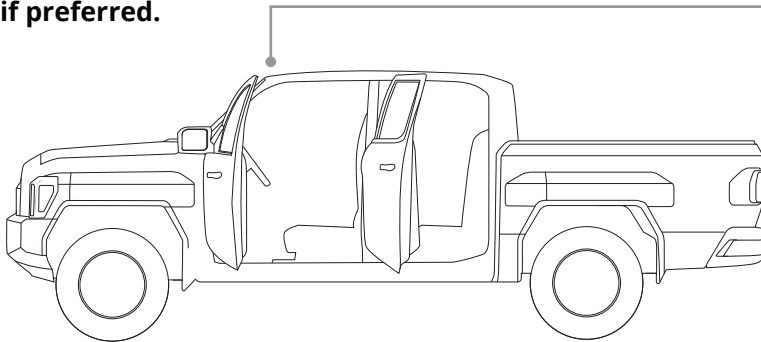

32

Install the stud plates as shown.

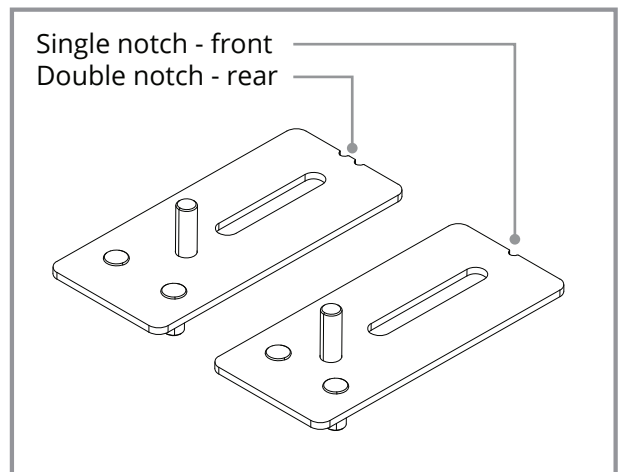
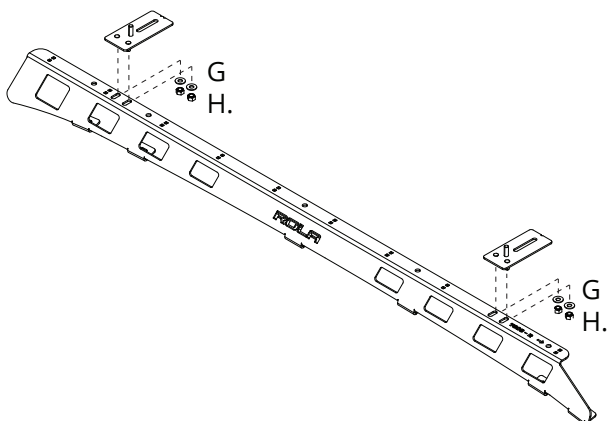

33

Install the Ridge Mount hardware.

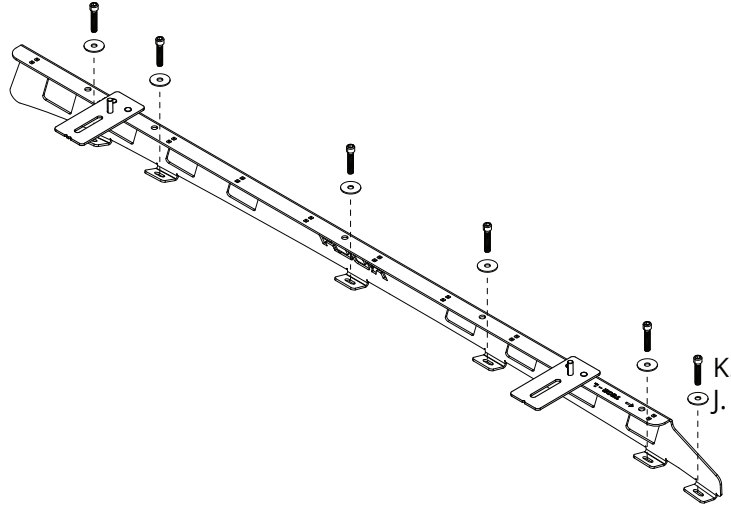

34

Fix the Ridge Mounts to the roof from the interior.

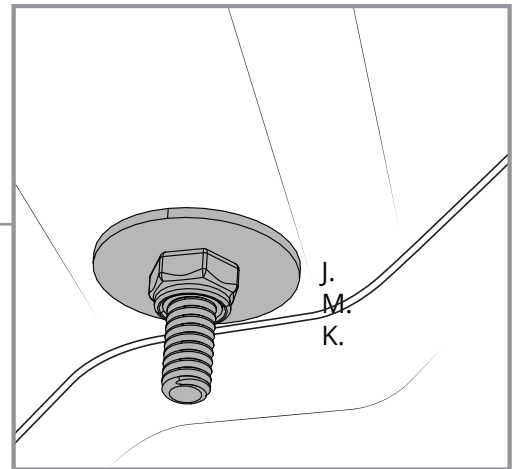
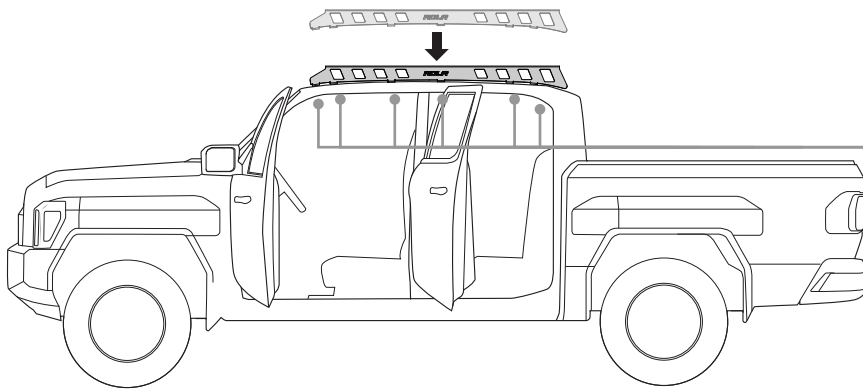

35

Replace the roof liner and interior to its original configurations.

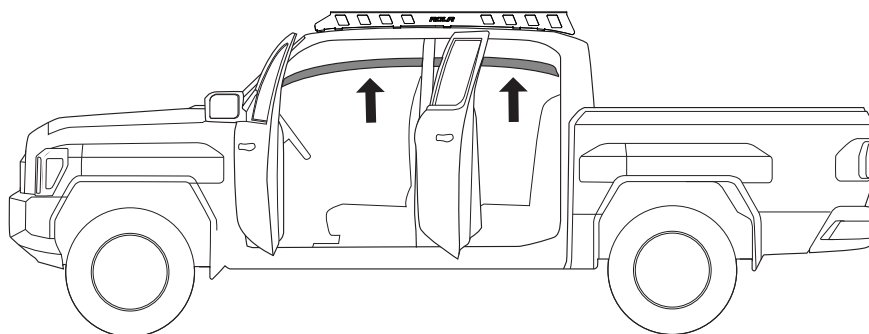

TITAN TRAY FITMENT

36

Install the Rola Titan Tray as per corresponding instructions.

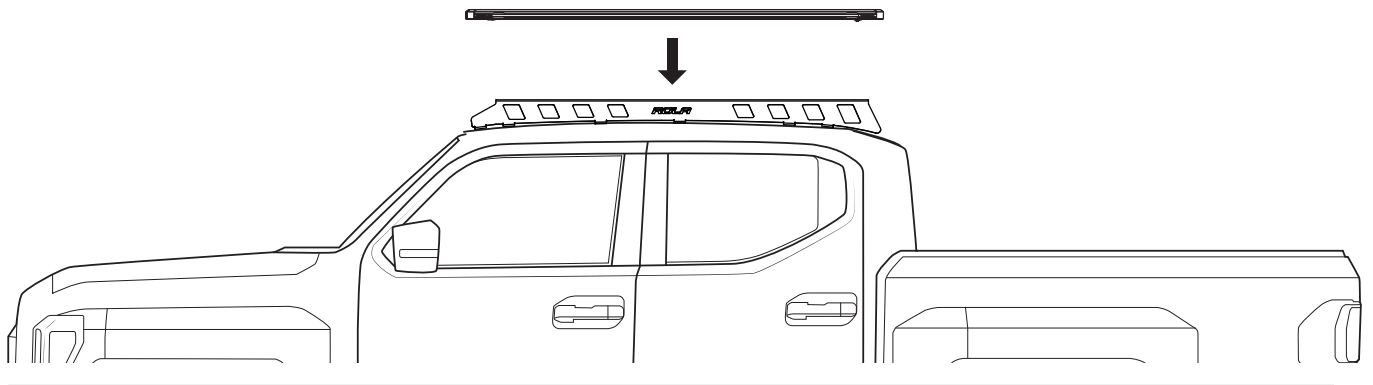
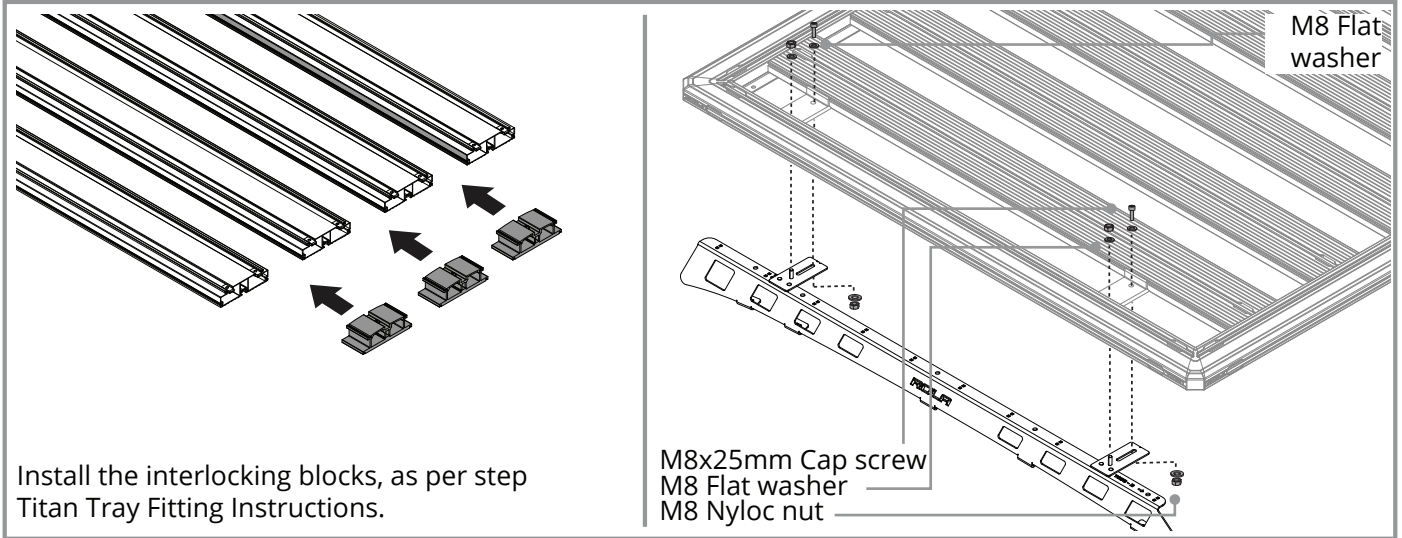

Note:

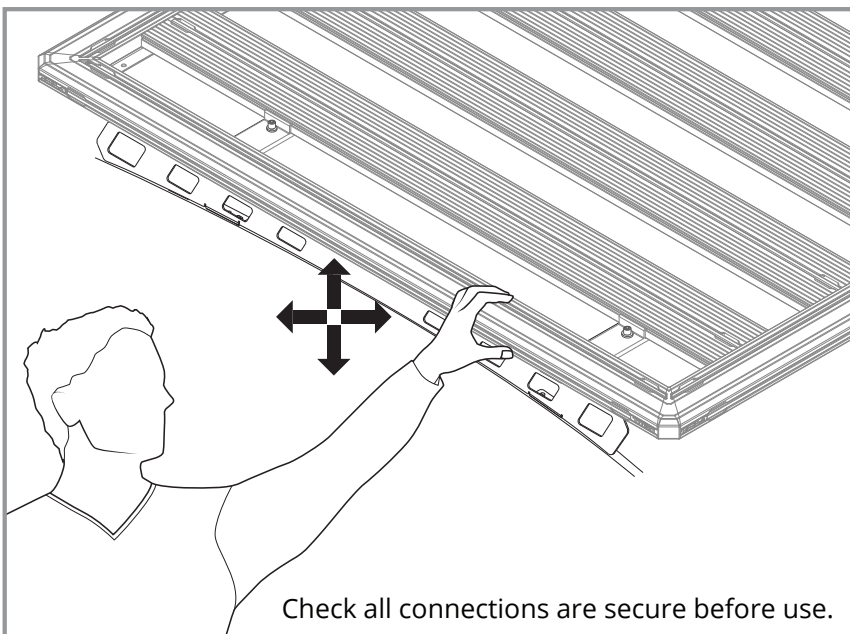

Wiring can be run and secured on the underside of the Ridge Mount rail as shown.

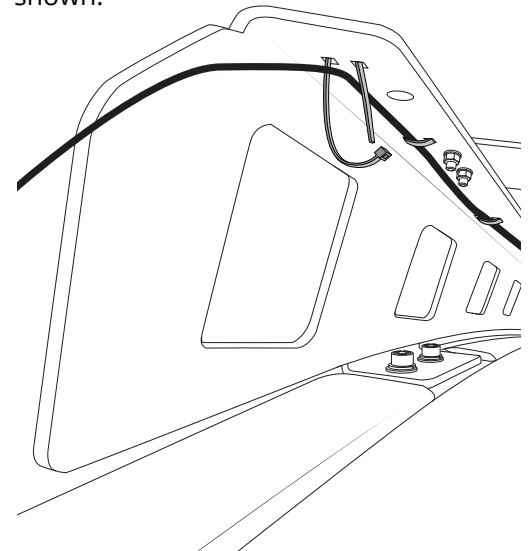

IMPORTANT - READ BEFORE USE

Please ensure the system is fitted in accordance with the fitting instructions. It is important that you observe all outlined below.

**WARRANTY INFORMATION**

Rola warrants that, subject to exclusions and limitations below, the system will be free from defects in materials and workmanship for a period of 2 years commencing on the date of sale by the authorized Rola stockist to the original purchaser of the system.

If a defect appears in the system before the end of the warranty period and Rola finds that the defect is in materials or workmanship, Rola will, in its sole discretion, either:

1. Repair the system or the defective component of the system free of charge
2. Replace the system or the defective component of the system; or
3. Refund the purchase price of the system to the original purchaser.

Rola reserves the right to change the design, specifications or composition of the system without notice and without liability. Rola reserves the right to replace defective products or components with products or components of similar quality, grade and composition, where an identical product or component is not available. Goods presented for repair may be replaced by refurbished goods of the same type rather than being repaired. Refurbished parts may be used to repair the goods. The 2 year warranty does not apply where:

1. The system is not installed in compliance with the fitting instructions provided
2. The system is not used as intended or designed
3. The system has been on-sold or assigned by the original purchaser
5. The system has been modified or repaired by someone other than Rola or an authorized Rola stockist
6. Rola cannot establish any fault after inspection of returned product
7. The system has been subject to abnormal conditions, including fire, water, humidity, pressure, stress or similar
8. The defect in the system has arisen due to abuse, misuse, neglect or accident
9. The defect in the system has arisen due to the unlawful or unusual operation of the vehicle to which it is fitted
10. The defect in the system has arisen due to the purchaser's failure to properly assemble, install, fit, maintain or use the system in accordance with the specifications and instructions provided by Rola.

For safety and use instructions, please refer to any General or Specific Fitting Instructions and Warning & Care Instructions enclosed within the system or on our website at www.rola.com.au.

This warranty does not extend to fair wear and tear. Warranty claims can be made by contacting Rola directly using the details below. A warranty claim must be accompanied by proof of purchase (such as receipt), details of the alleged defect and appropriate documentation (such as historical and maintenance records where appropriate). The customer must make the product available to Rola or its authorized repair agent for inspection and testing. If such inspection and testing finds no defect in the product, the customer must pay Rola usual costs of service work and testing. It is the purchaser's responsibility to arrange and pay to return the product or component to the place of purchase. The purchaser may seek reimbursement from Rola for the cost of such activities, providing Rola notifies the purchaser in writing that a warranty claim is justified. Any such claims made must be in writing via post or email.

The benefits of this warranty are in addition to any rights and remedies imposed by Australian State and Federal legislation that cannot be executed. Nothing in this warranty is to be interpreted as excluding, restricting or modifying any State or Federal legislation applicable to the supply of goods and services which cannot be so excluded, restricted or modified. Our goods come with guarantees that cannot be excluded under the Australian Consumer Law. You are entitled to a replacement or refund for a major failure and for compensation for any other reasonably foreseeable loss or damage. You are also entitled to have the goods repaired or replaced if the goods fail to be of acceptable quality and the failure does not amount to a major failure. Rola makes no express warranties or representations other than set out in this warranty.

SAFETY REQUIREMENTS

Manufactures roof weight limit - rack system weight = Max carrying capacity.

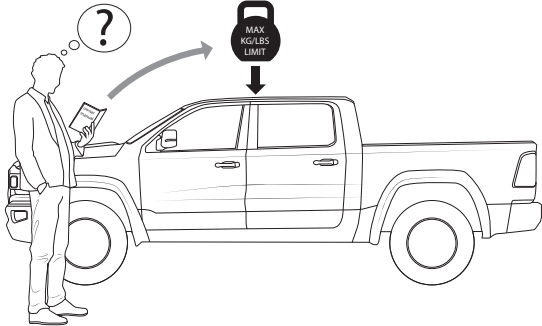

Cross reference with system max carrying capacity. **Always use the lower of the two figures.**

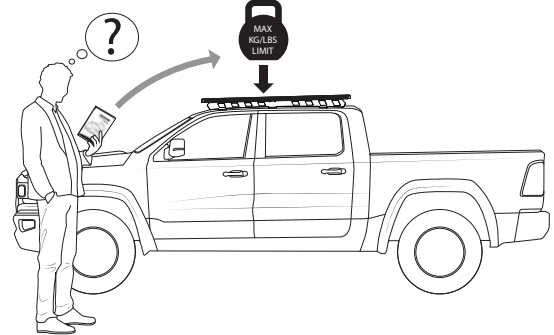

IMPORTANT - Off-road load rating reduction.

System	Track Mount	Anchor Point	Gutter Mount	Raised Rail	Flush Rail	Clamp Mount
Platform+ Ridge Mount	0%	0%	25%	0%	N/A	N/A
Platform+ Low Mount	33%	33%	33%	33%	33%	50%
Sports Extended	33%	33%	33%	33%	33%	50%
Sports Concealed	33%	33%	33%	33%	33%	50%

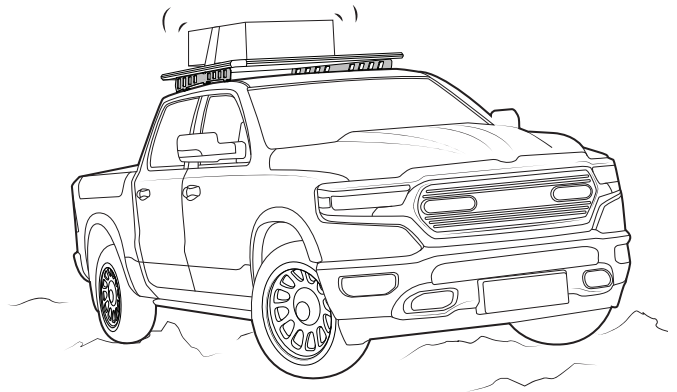

Distribute carried load evenly longitudinally and as low as possible. Do not concentrate loads front or rear.

CORRECT

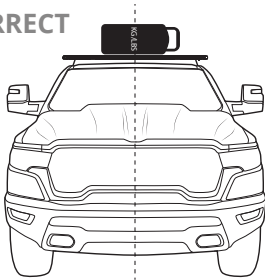

CORRECT

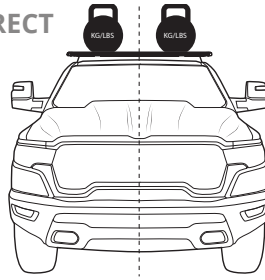

✗

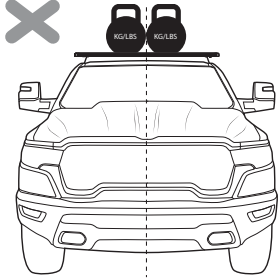

CORRECT

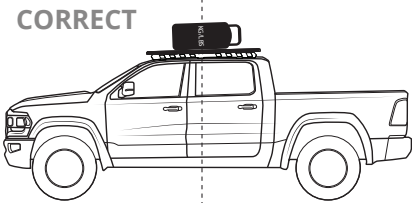

CORRECT

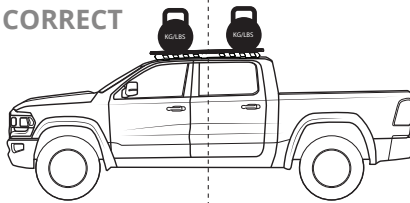

✗

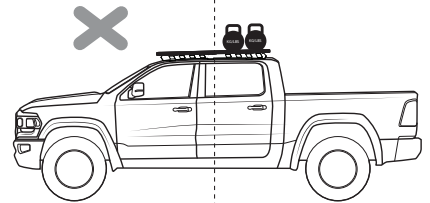

✗

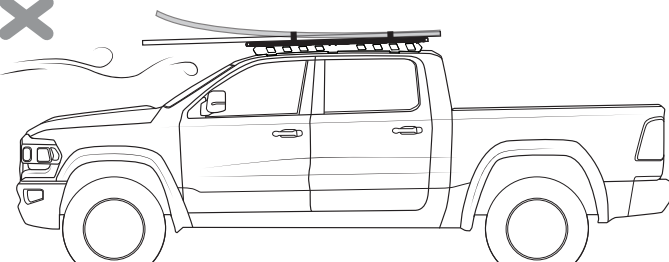

CORRECT

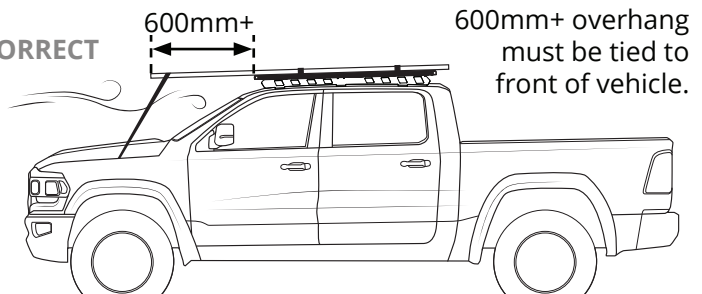

600mm+ overhang must be tied to front of vehicle.

SAFETY REQUIREMENTS

