

# RIDGE MOUNT

by **ROLA**<sup>®</sup>

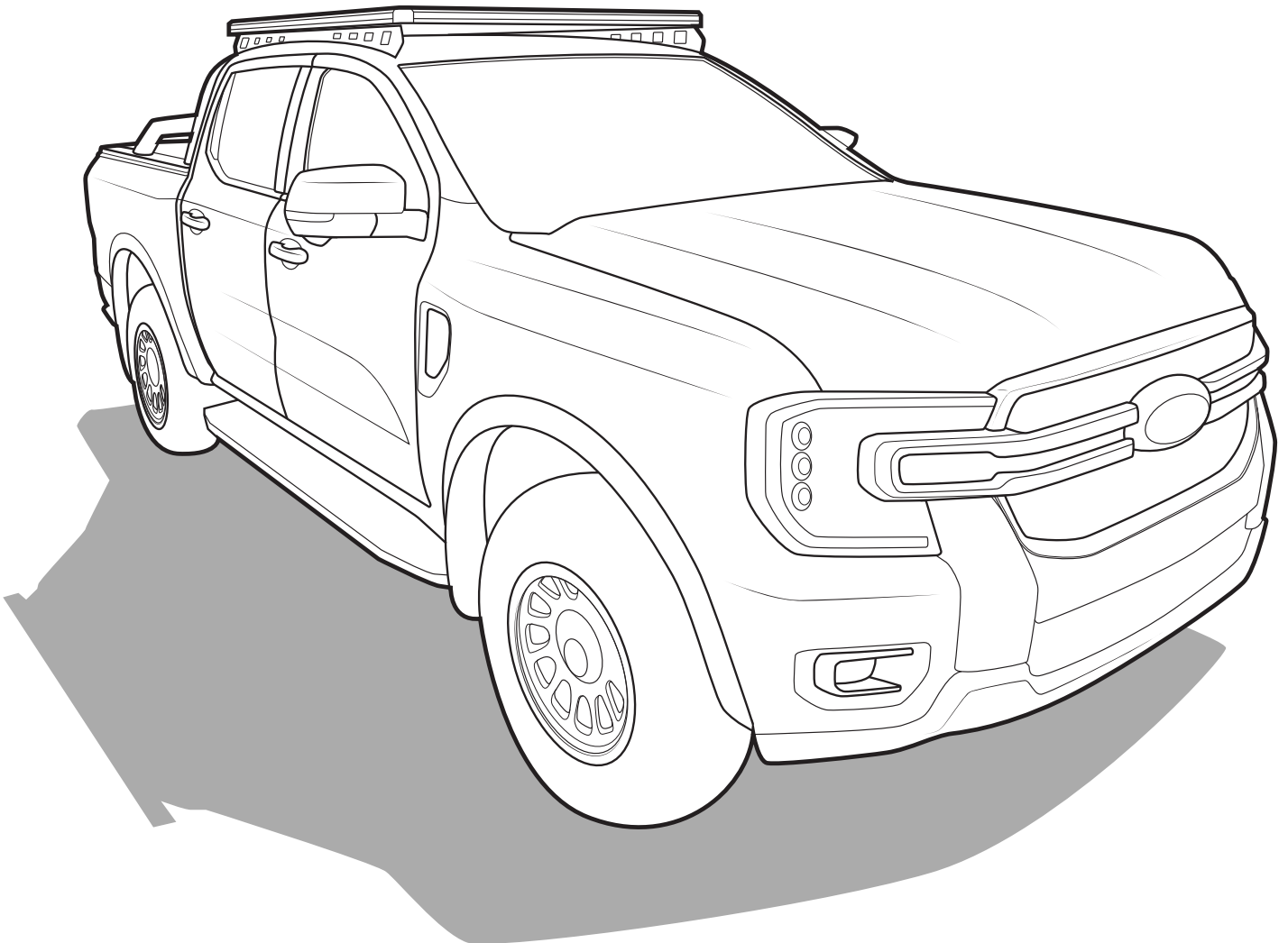

**IMPORTANT:** This kit is intended for fitment with ROLA R-BAR-FR-01 systems or equivalent.

FORD RANGER P703 and PX 1-3  
VOLKSWAGEN GEN 2 UTE

RIDGE MOUNT SYSTEM  
RM37305 Issue 01

Read this full instruction prior to commencing assembly and fitment of Ridge Mount System.

**CONTENT - CHECK ALL PARTS ARE CORRECT BEFORE PROCEEDING**

A		Ridge Mount (pair)	1
B		Stud Plate	4
C		M8x25mm Socket Head Screw	8
D		M8 Flat Washer	32
E		M8 Nyloc Nut	24
F		M8 x 20mm Drop and Turn Channel Bolt	8
G		Interlocking Block	3

**TOOLS REQUIRED**

- 6mm Allen Key.
- 13mm Spanner.
- Socket set.
- Step Ladder.
- Tape Measure.

1

Move to the side of the vehicle. Use a step ladder to get access to the vehicle.

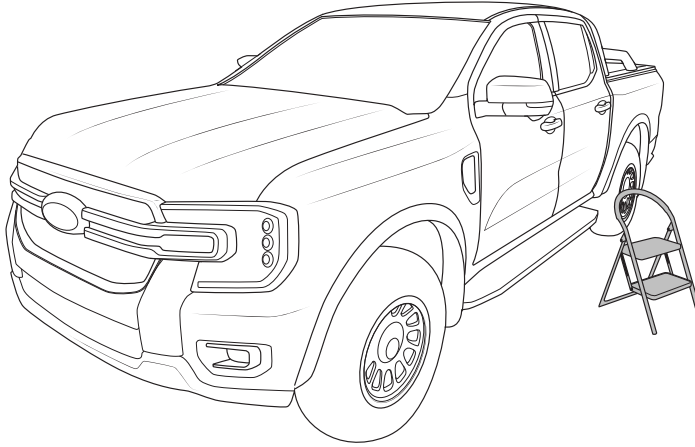

2

Install the Rola Ford Ranger/ VW Amarok Tracks as per corresponding instructions.

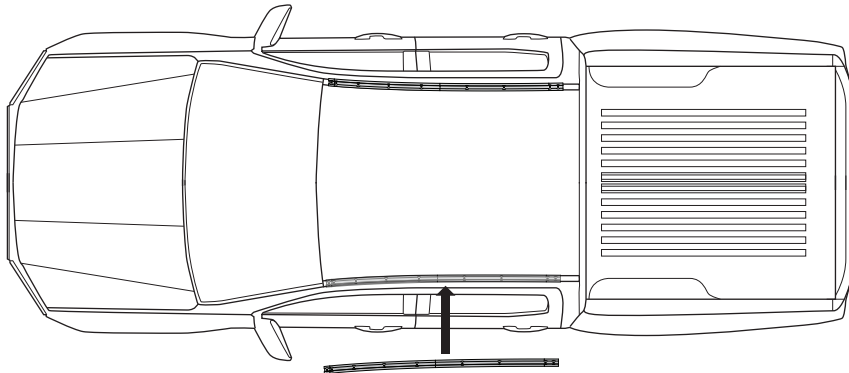

3

Slide 4x drop and turn bolts into the installed tracks.

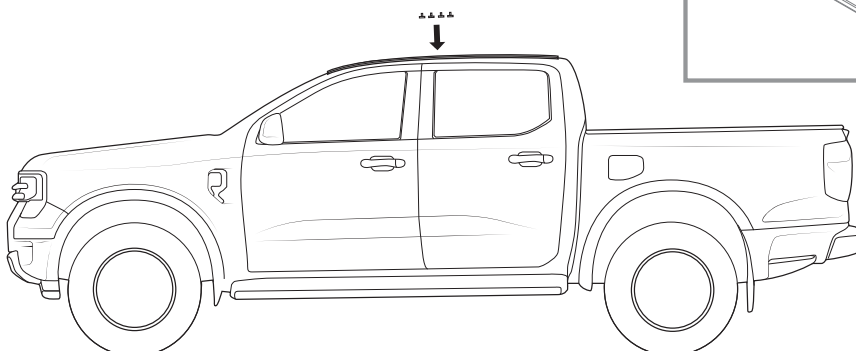
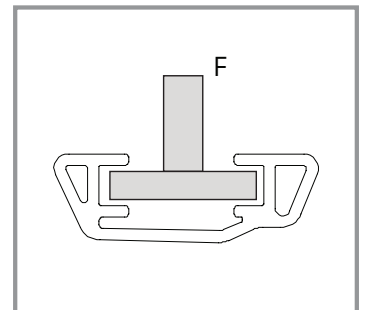
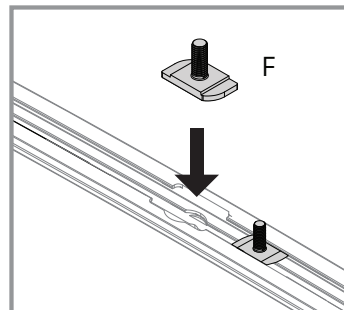

4

Using the M8 flat washers and nyloc nuts, finger tighten the Ridge Mounts to the installed tracks.

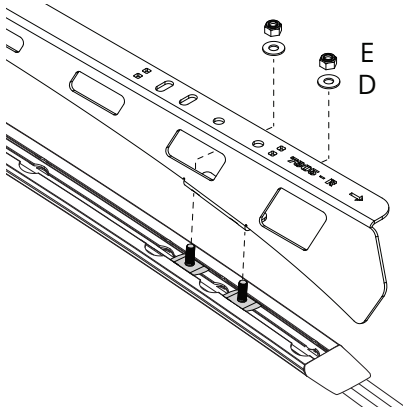

Measure 160 mm from the end of the installed track and align the back edge of the Ridge Mount's rear mounting foot at this mark.

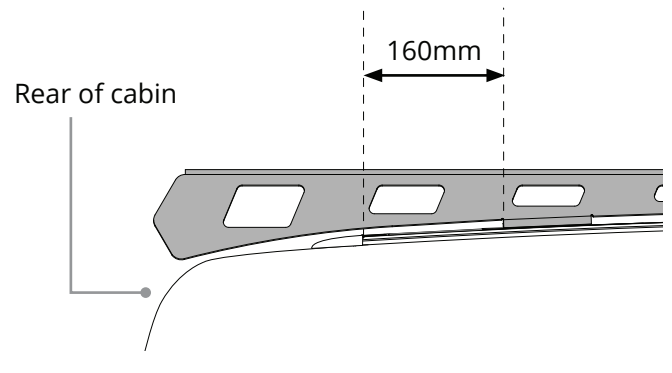

5

Fix in place with a 13mm socket or spanner.

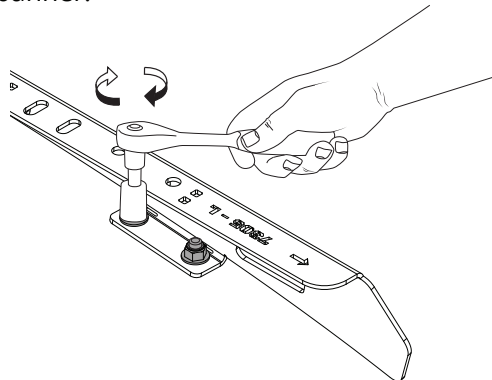

6

Install the stud plates with M8 hardware provided.

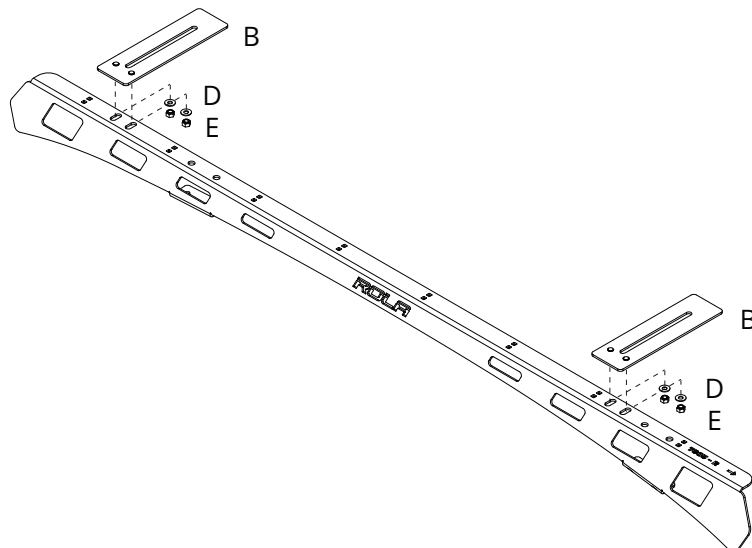

TITAN TRAY FITMENT

7

Install the Rola Titan Tray as per corresponding instructions.

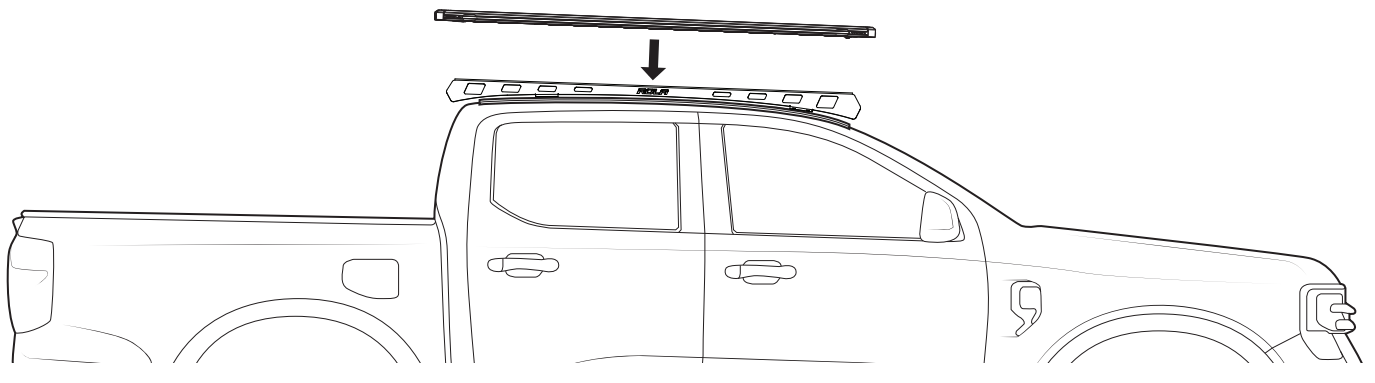
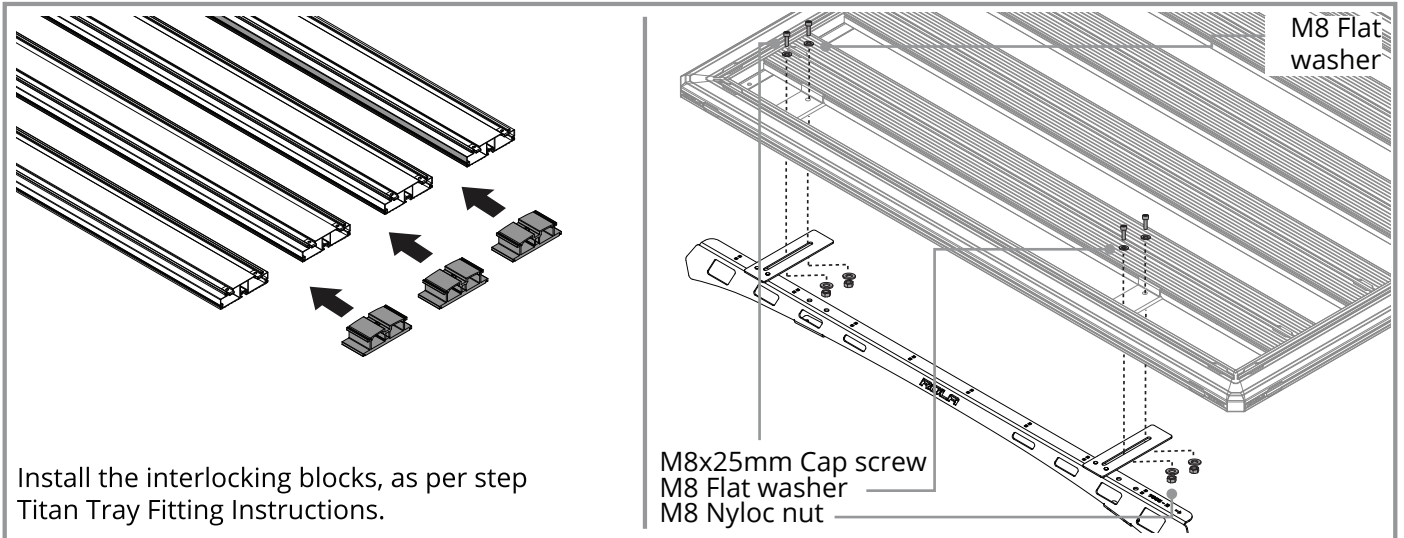

Note:

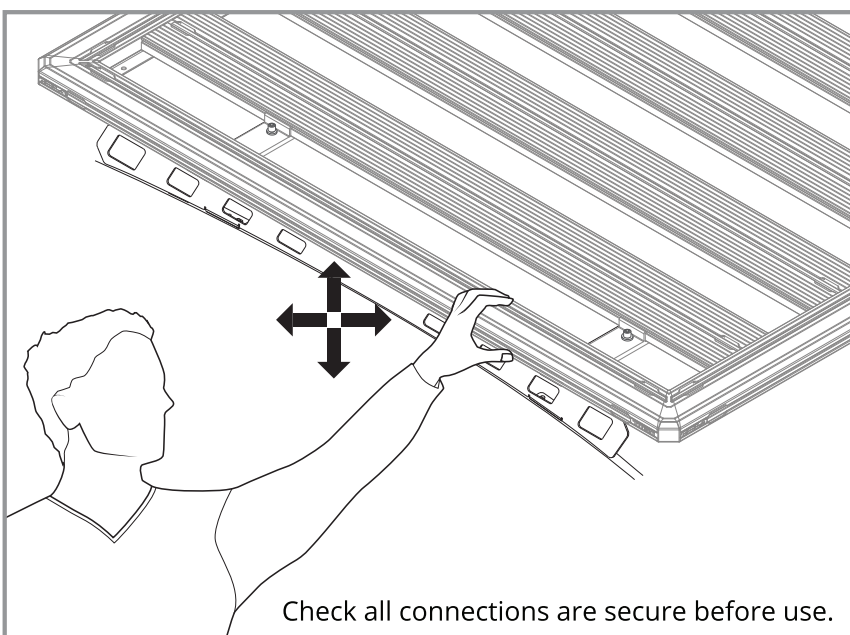

Wiring can be run and secured on the underside of the Ridge Mount rail as shown.

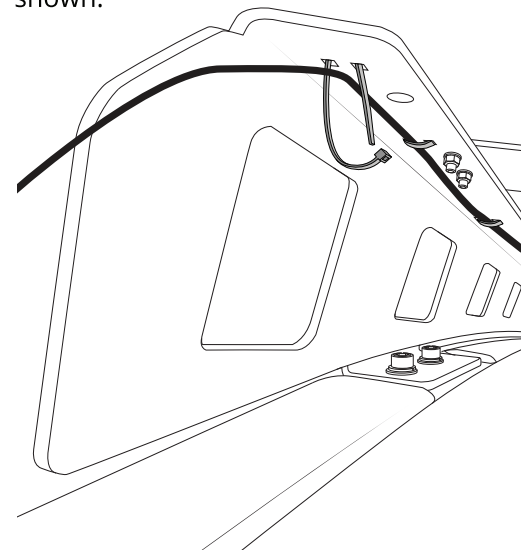

**IMPORTANT - READ BEFORE USE**

Please ensure the system is fitted in accordance with the fitting instructions. It is important that you observe all outlined below.

**WARRANTY INFORMATION**

Rola warrants that, subject to exclusions and limitations below, the system will be free from defects in materials and workmanship for a period of 2 years commencing on the date of sale by the authorized Rola stockist to the original purchaser of the system.

If a defect appears in the system before the end of the warranty period and Rola finds that the defect is in materials or workmanship, Rola will, in its sole discretion, either:

1. Repair the system or the defective component of the system free of charge
2. Replace the system or the defective component of the system; or
3. Refund the purchase price of the system to the original purchaser.

Rola reserves the right to change the design, specifications or composition of the system without notice and without liability. Rola reserves the right to replace defective products or components with products or components of similar quality, grade and composition, where an identical product or component is not available. Goods presented for repair may be replaced by refurbished goods of the same type rather than being repaired. Refurbished parts may be used to repair the goods. The 2 year warranty does not apply where:

1. The system is not installed in compliance with the fitting instructions provided
2. The system is not used as intended or designed
3. The system has been on-sold or assigned by the original purchaser
5. The system has been modified or repaired by someone other than Rola or an authorized Rola stockist
6. Rola cannot establish any fault after inspection of returned product
7. The system has been subject to abnormal conditions, including fire, water, humidity, pressure, stress or similar
8. The defect in the system has arisen due to abuse, misuse, neglect or accident
9. The defect in the system has arisen due to the unlawful or unusual operation of the vehicle to which it is fitted
10. The defect in the system has arisen due to the purchaser's failure to properly assemble, install, fit, maintain or use the system in accordance with the specifications and instructions provided by Rola.

For safety and use instructions, please refer to any General or Specific Fitting Instructions and Warning & Care Instructions enclosed within the system or on our website at [www.rola.com.au](http://www.rola.com.au).

This warranty does not extend to fair wear and tear. Warranty claims can be made by contacting Rola directly using the details below. A warranty claim must be accompanied by proof of purchase (such as receipt), details of the alleged defect and appropriate documentation (such as historical and maintenance records where appropriate). The customer must make the product available to Rola or its authorized repair agent for inspection and testing. If such inspection and testing finds no defect in the product, the customer must pay Rola usual costs of service work and testing. It is the purchaser's responsibility to arrange and pay to return the product or component to the place of purchase. The purchaser may seek reimbursement from Rola for the cost of such activities, providing Rola notifies the purchaser in writing that a warranty claim is justified. Any such claims made must be in writing via post or email.

The benefits of this warranty are in addition to any rights and remedies imposed by Australian State and Federal legislation that cannot be executed. Nothing in this warranty is to be interpreted as excluding, restricting or modifying any State or Federal legislation applicable to the supply of goods and services which cannot be so excluded, restricted or modified. Our goods come with guarantees that cannot be excluded under the Australian Consumer Law. You are entitled to a replacement or refund for a major failure and for compensation for any other reasonably foreseeable loss or damage. You are also entitled to have the goods repaired or replaced if the goods fail to be of acceptable quality and the failure does not amount to a major failure. Rola makes no express warranties or representations other than set out in this warranty.

SAFETY REQUIREMENTS

Manufactures roof weight limit - rack system weight = Max carrying capacity.

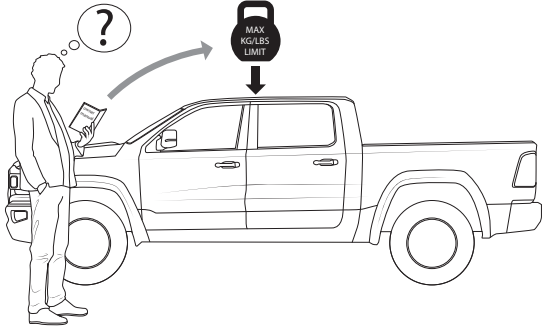

Cross reference with system max carrying capacity. **Always use the lower of the two figures.**

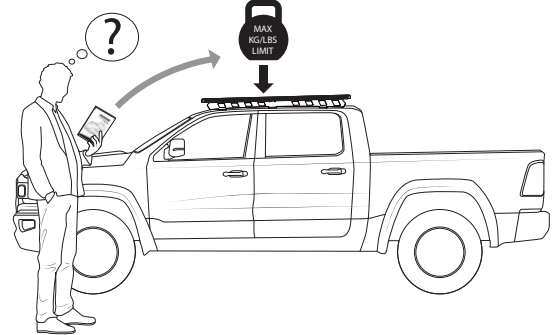

**IMPORTANT - Off-road load rating reduction.**

System	Track Mount	Anchor Point	Gutter Mount	Raised Rail	Flush Rail	Clamp Mount
Platform+ Ridge Mount	0%	0%	25%	0%	N/A	N/A
Platform+ Low Mount	33%	33%	33%	33%	33%	50%
Sports Extended	33%	33%	33%	33%	33%	50%
Sports Concealed	33%	33%	33%	33%	33%	50%

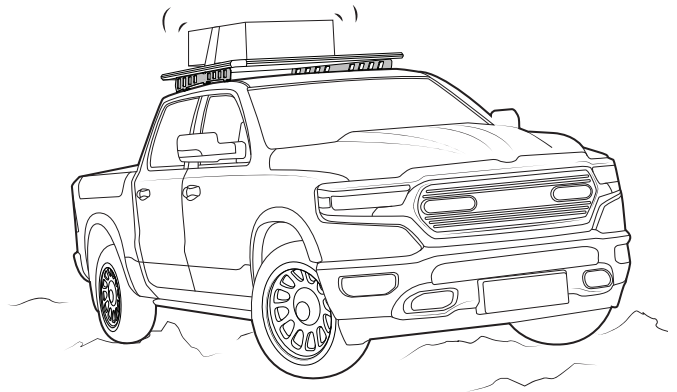

Distribute carried load evenly longitudinally and as low as possible. Do not concentrate loads front or rear.

CORRECT

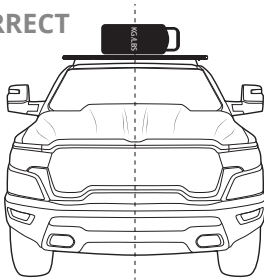

CORRECT

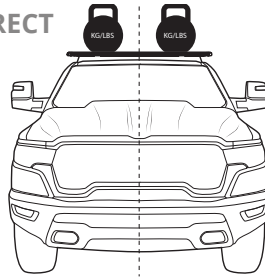

✗

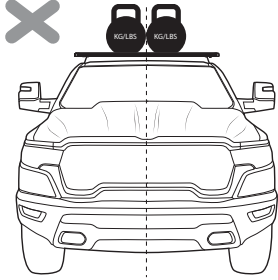

CORRECT

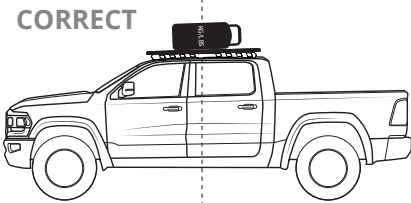

CORRECT

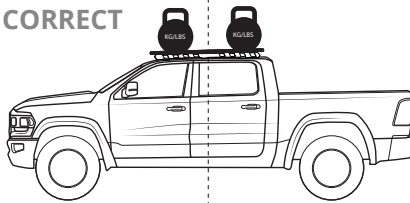

✗

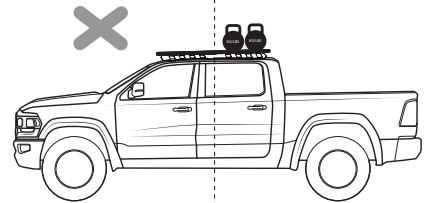

✗

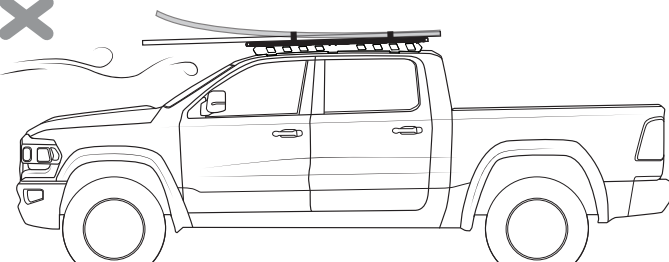

CORRECT

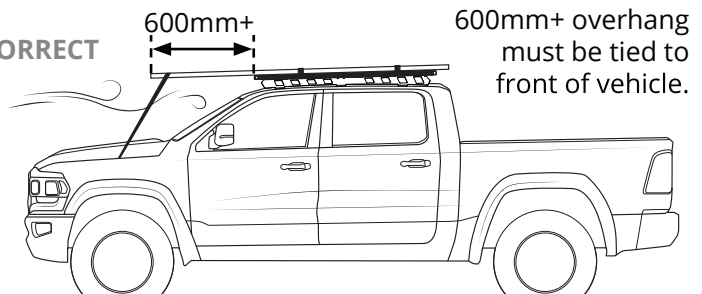

SAFETY REQUIREMENTS

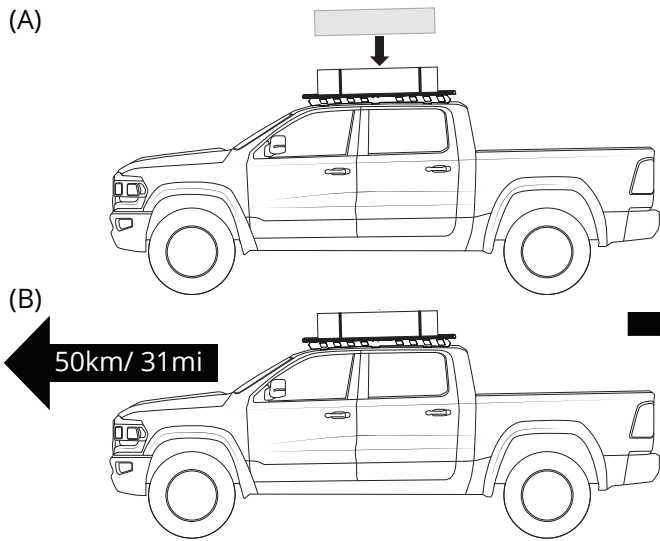

Check all fixtures are secured and torqued correctly.

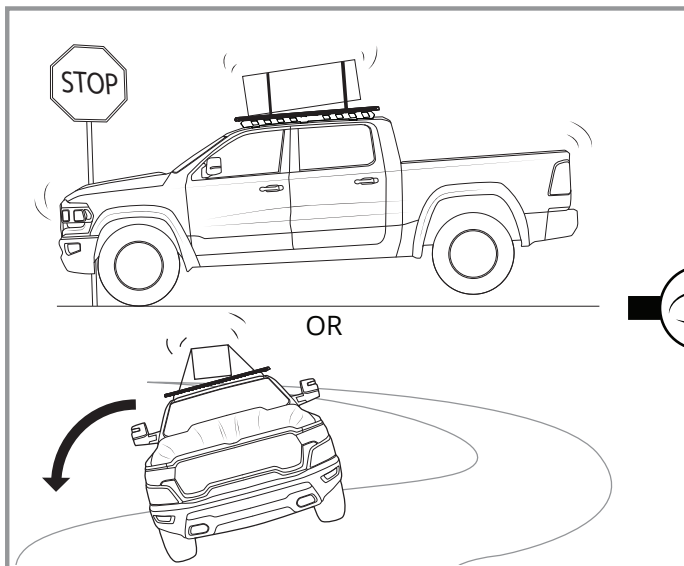
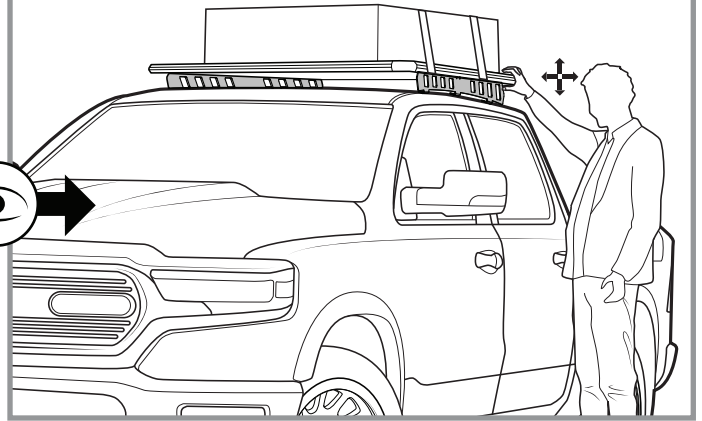

Check all fixtures are secured and torqued correctly.

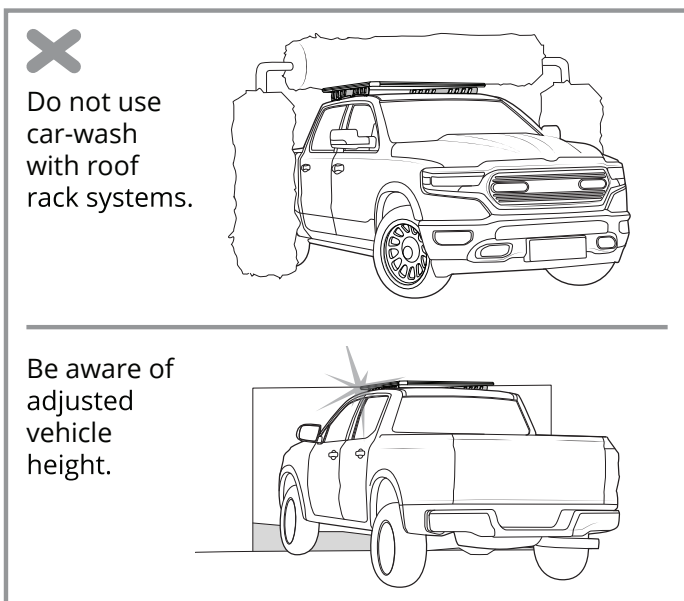
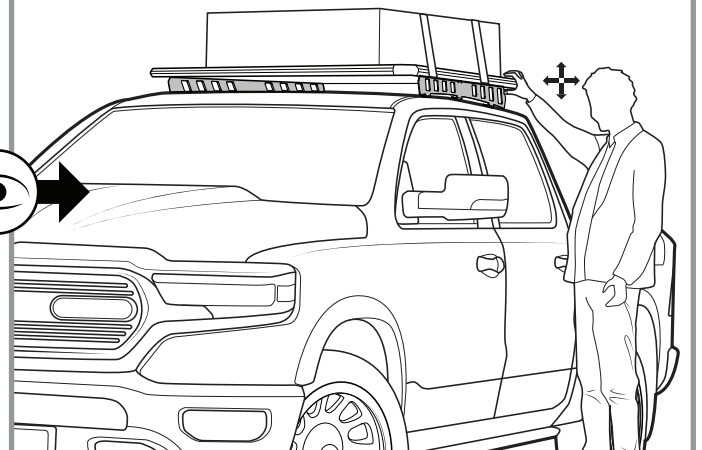

Cab and canopy can move independently, do not fix load across both.

Long loads fixed at front only.

