

RIDGE MOUNT

by **ROLA**[®]

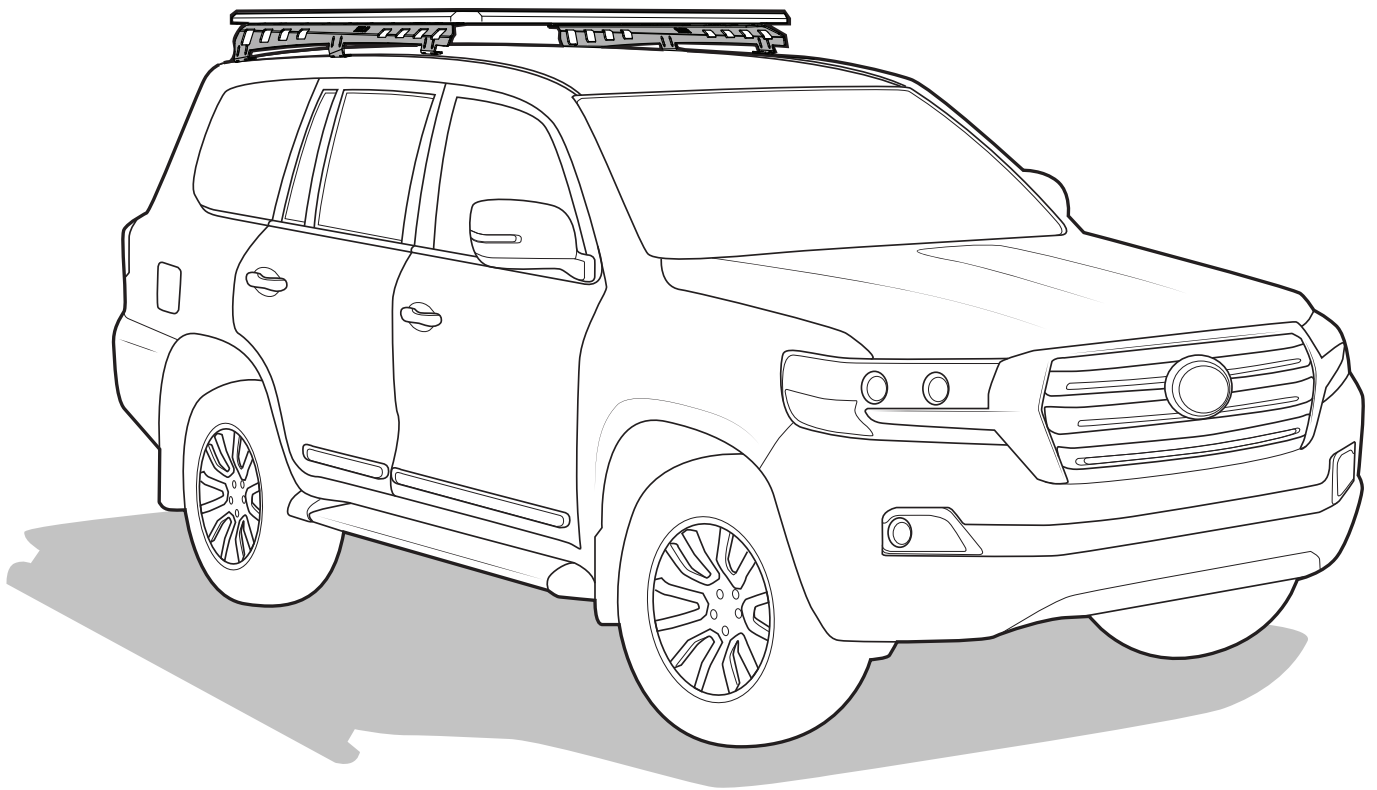

TOYOTA LC200 - SHORT RIDGE MOUNT SYSTEM

RM37317 - Issue 01

CONTENT - CHECK ALL PARTS ARE CORRECT BEFORE PROCEEDING

| | | | |
|---|--|---------------------|----|
| A | | Ridge Mount (pair) | 1 |
| B | | Stud Plate | 4 |
| C | | M8 x 30mm Cap Screw | 16 |
| D | | M8 x 25mm Cap Screw | 8 |
| E | | M8 Washer | 40 |
| F | | M8 Nyloc Nut | 16 |
| G | | Butyl Patch | 16 |
| H | | Cover Plate | 2 |
| I | | Interlocking Block | 3 |

TOOLS REQUIRED

- 6mm allen tool.
- 10mm socket wrench
- 13mm spanner.
- Step ladder.
- Butyl mastic sealant.
- Flat blade screwdriver.
- Trim removal tool.

FACTORY RAIL REMOVAL - FOR BARE ROOF TURN Pg 5

1

Move to the side of the vehicle. Use a step ladder to get access to the top of the vehicle.

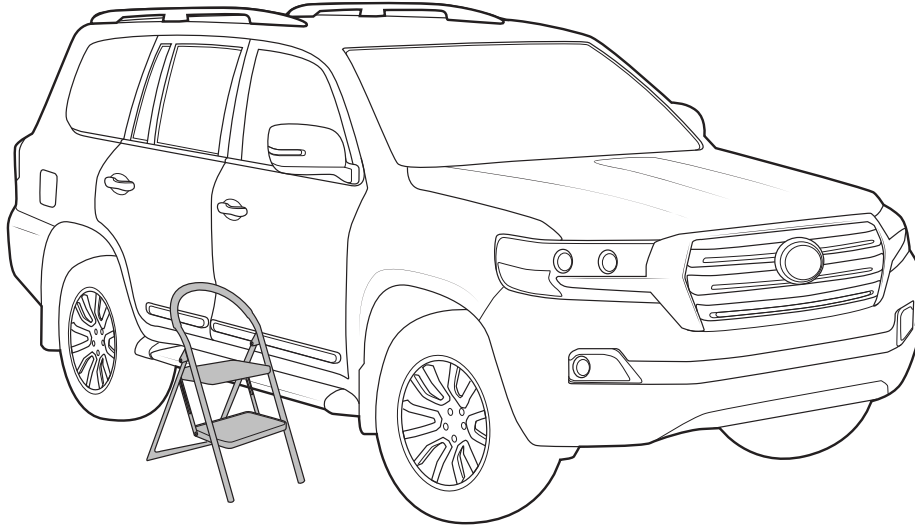

2

Using a ditch removal tool, carefully pry off the rail covers at the front, middle and rear.

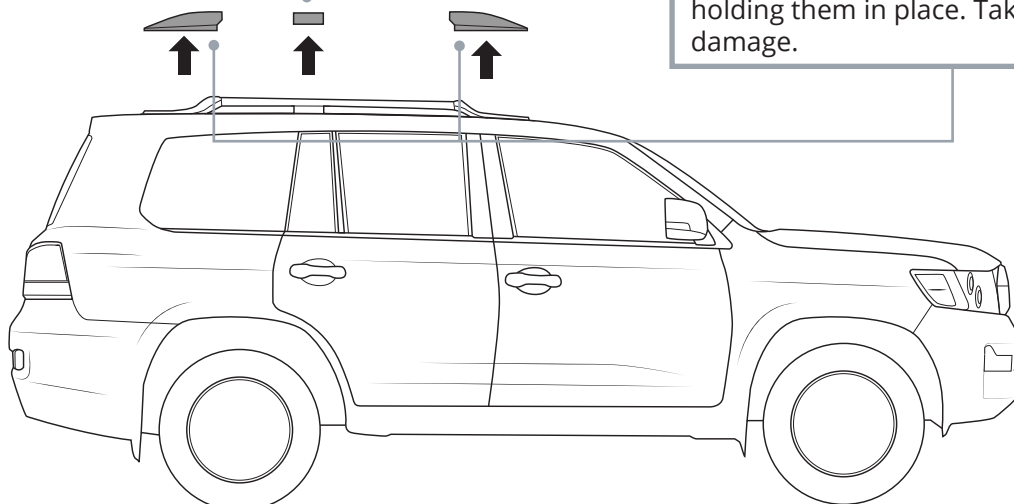
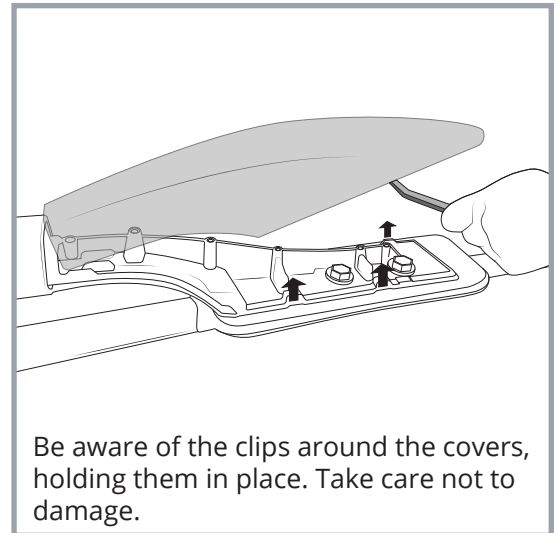
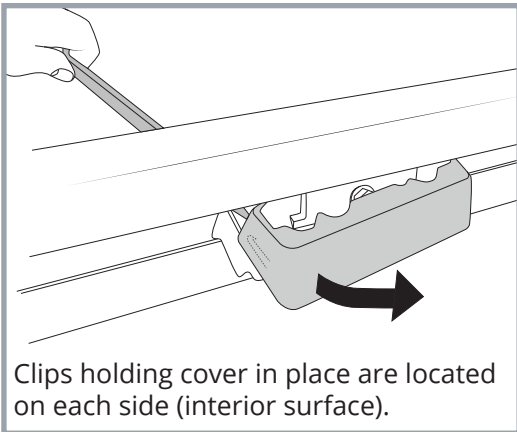

3

Using a 13mm socket wrench, carefully remove the bolts holding the rail in place.

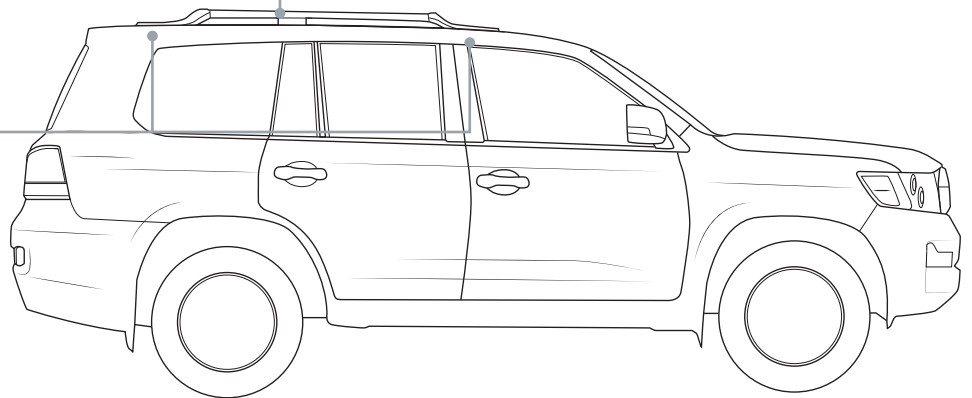
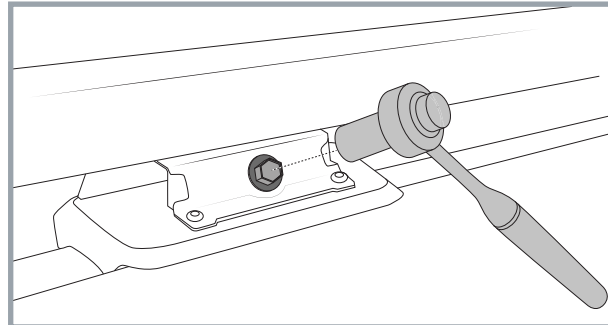
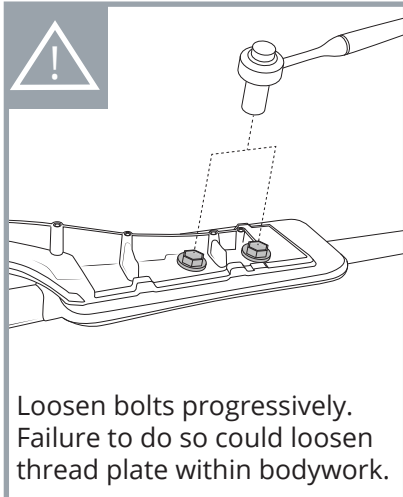

4

Carefully remove the factory rails. Clean the roof of the vehicle thoroughly.

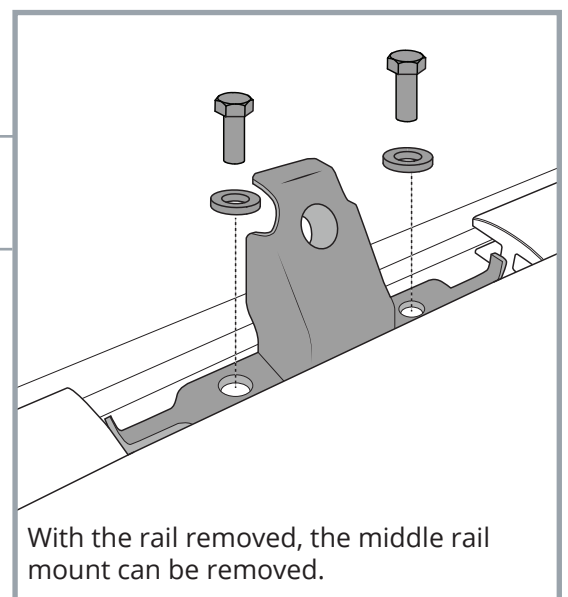
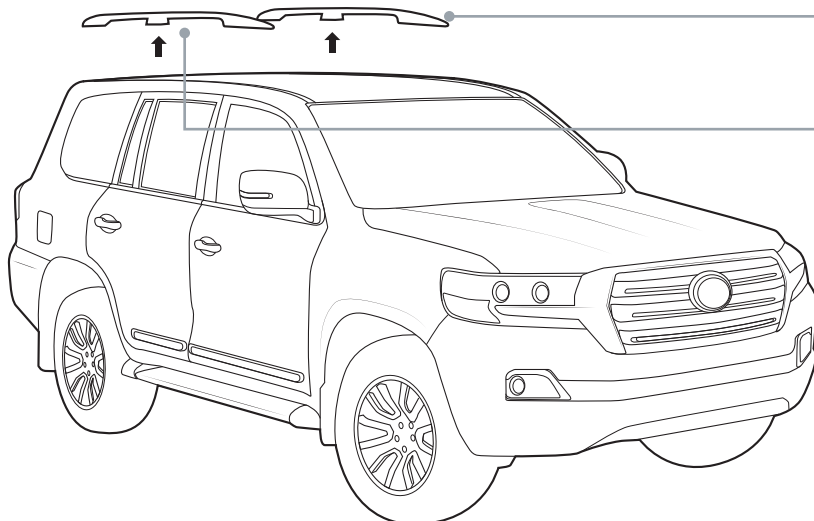

BARE ROOF INSTALL 5

Carefully remove the rear and middle mounting point covers from the roof only.

Do not remove the front most covers.

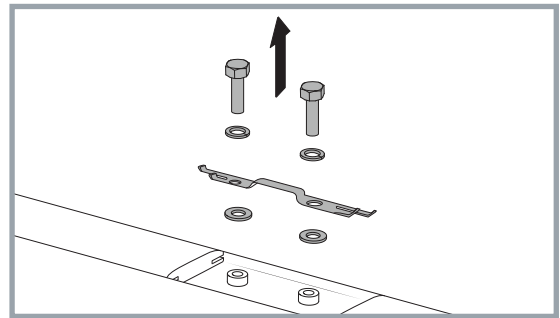
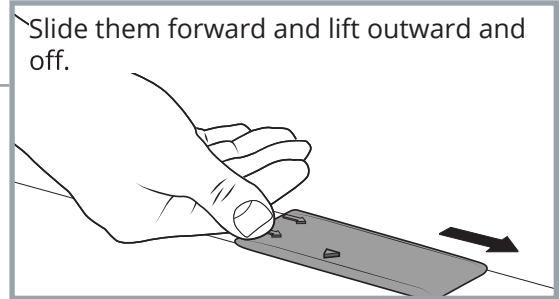
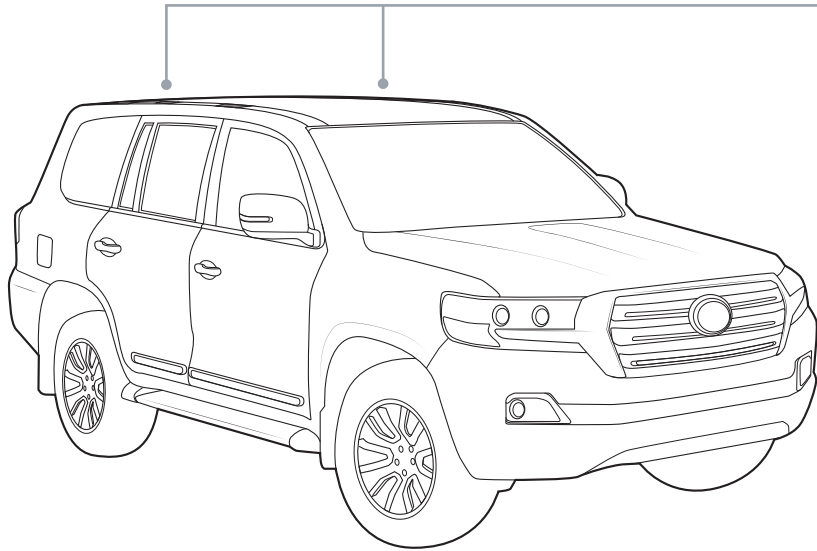

6

Add 2x butyl patches to the exposed threads in the roof.

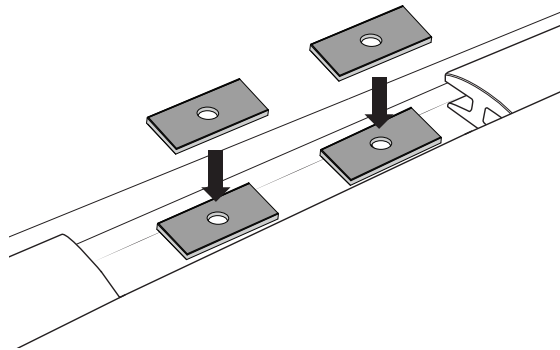
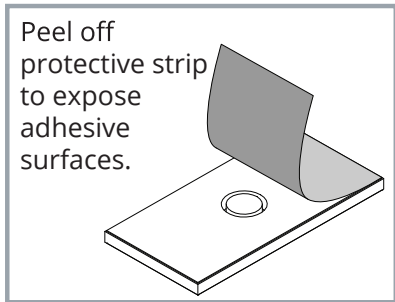

FACTORY RAIL ONLY 7

Install a cover plate with M8 x 30mm cap screws and flat washers.

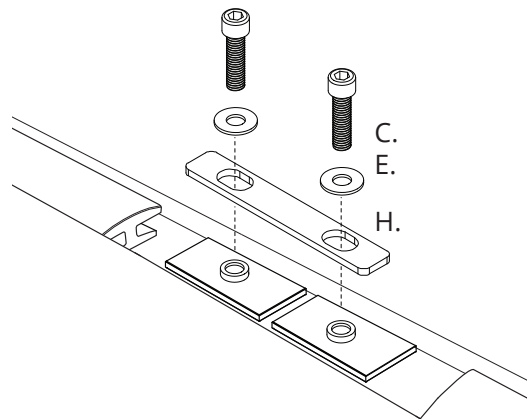

Assemble M8 hardware into the Ridge Mount Rails as shown.

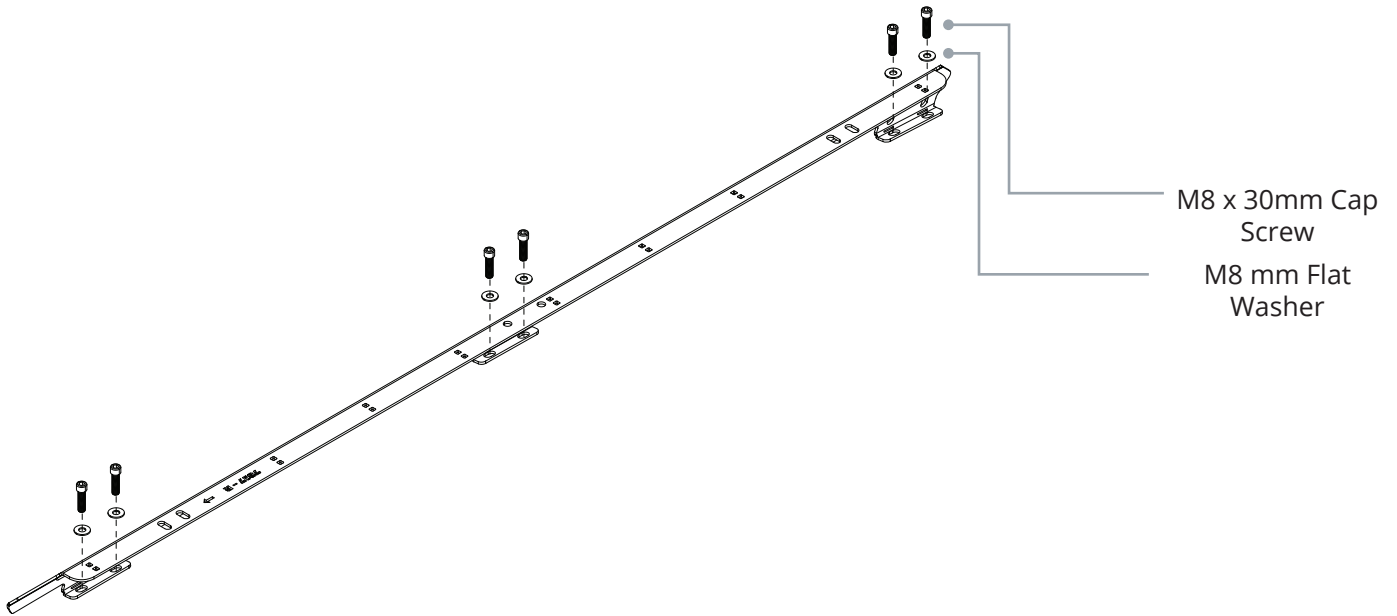

Install the Ridge Mount hardware as shown below. Tighten with a 13mm spanner.

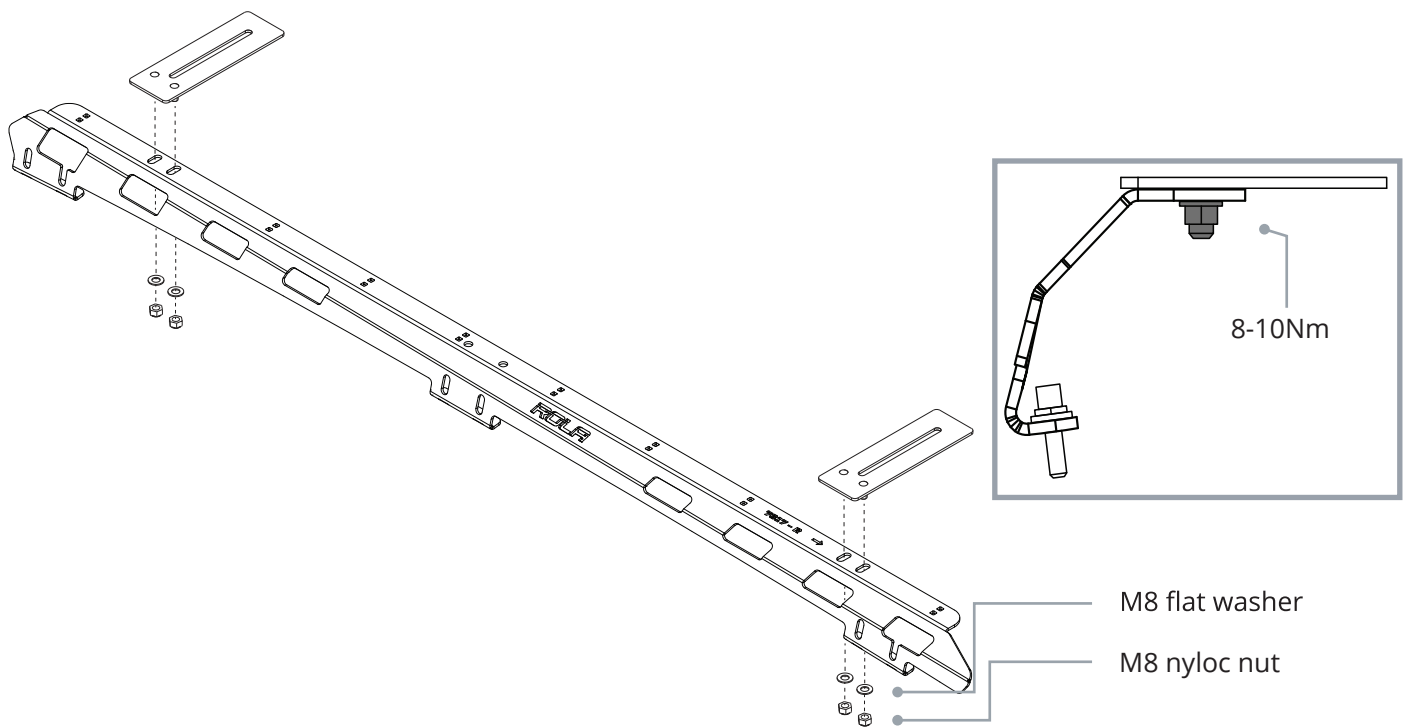

9

Place the Ridge Mount assembly onto the roof. The M8 hardware will pick up the factory threads in the roof.

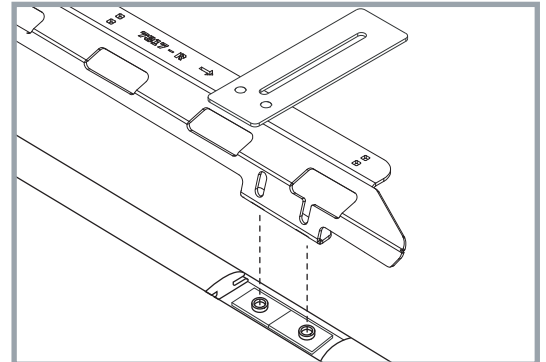
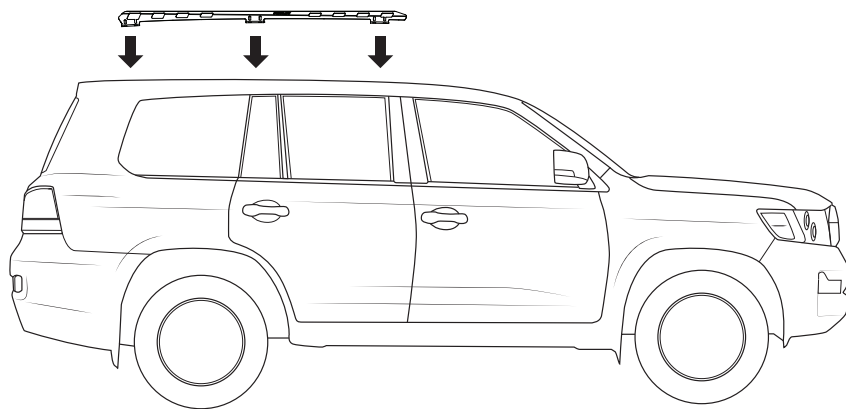

Fitment area can be constrained and access difficult. If so, tilt the Ridge Mount slightly to assist.

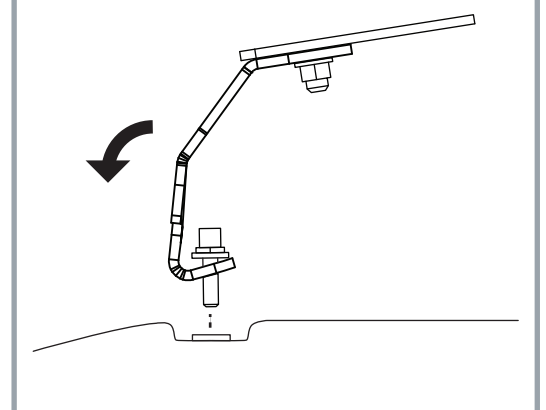

10

Tighten the M8 hardware with a 6mm allen key to 4-5Nm.

Note: Access hardware through cutouts on side or holes located on top of the rail.

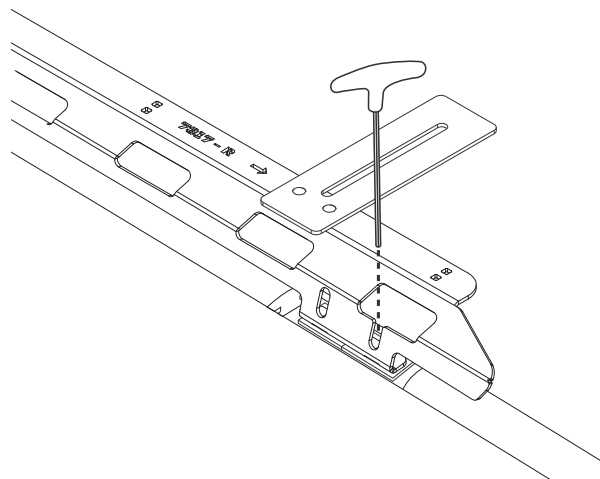

TITAN TRAY FITMENT

11

Install the Rola Titan Tray as per corresponding instructions.

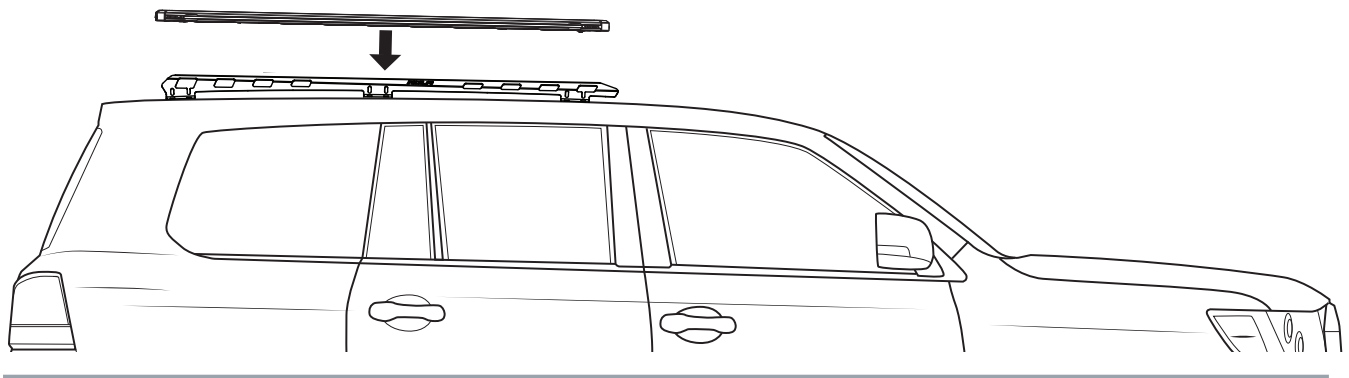
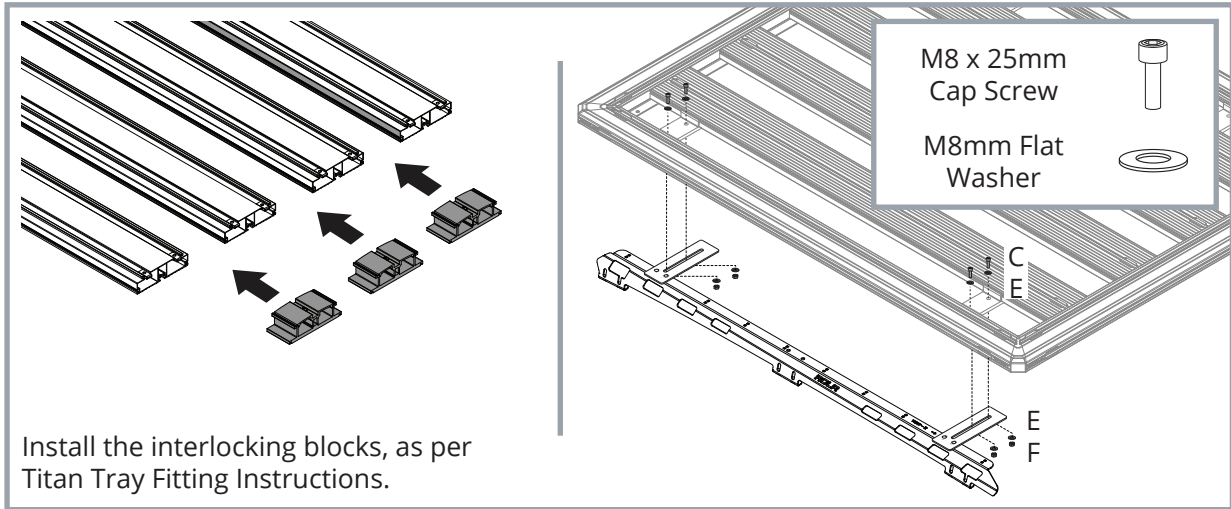

Note:

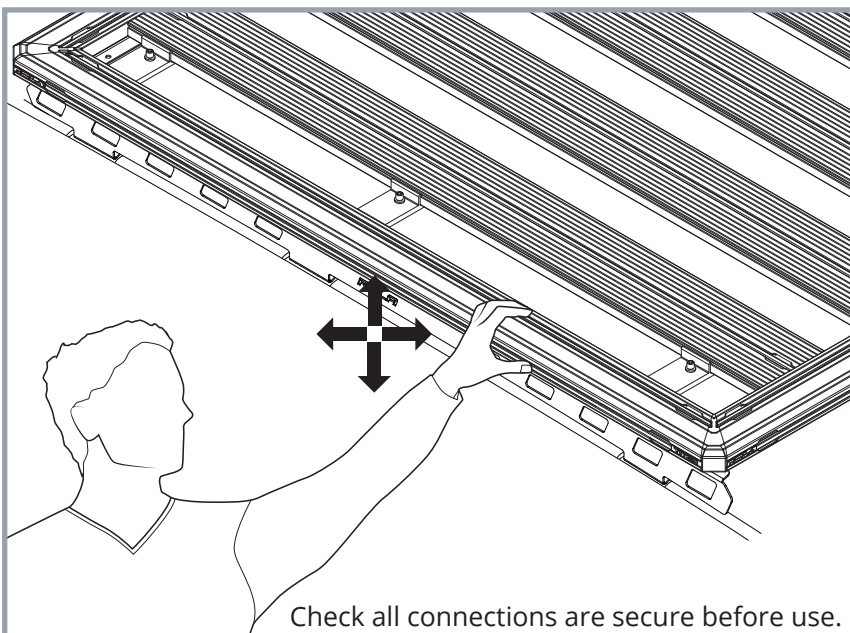

Wiring can be run and secured on the underside of the mount rail as shown.

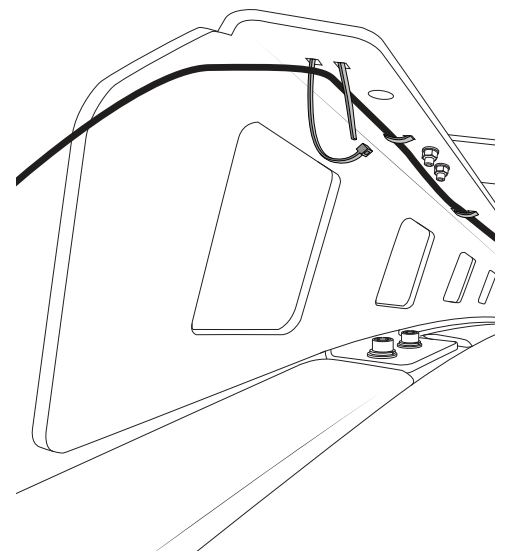

IMPORTANT - READ BEFORE USE

Please ensure the system is fitted in accordance with the fitting instructions. It is important that you observe all outlined below.

**WARRANTY INFORMATION**

Rola warrants that, subject to exclusions and limitations below, the system will be free from defects in materials and workmanship for a period of 2 years commencing on the date of sale by the authorized Rola stockist to the original purchaser of the system.

If a defect appears in the system before the end of the warranty period and Rola finds that the defect is in materials or workmanship, Rola will, in its sole discretion, either:

1. Repair the system or the defective component of the system free of charge
2. Replace the system or the defective component of the system; or
3. Refund the purchase price of the system to the original purchaser.

Rola reserves the right to change the design, specifications or composition of the system without notice and without liability. Rola reserves the right to replace defective products or components with products or components of similar quality, grade and composition, where an identical product or component is not available. Goods presented for repair may be replaced by refurbished goods of the same type rather than being repaired. Refurbished parts may be used to repair the goods. The 2 year warranty does not apply where:

1. The system is not installed in compliance with the fitting instructions provided
2. The system is not used as intended or designed
3. The system has been on-sold or assigned by the original purchaser
5. The system has been modified or repaired by someone other than Rola or an authorized Rola stockist
6. Rola cannot establish any fault after inspection of returned product
7. The system has been subject to abnormal conditions, including fire, water, humidity, pressure, stress or similar
8. The defect in the system has arisen due to abuse, misuse, neglect or accident
9. The defect in the system has arisen due to the unlawful or unusual operation of the vehicle to which it is fitted
10. The defect in the system has arisen due to the purchaser's failure to properly assemble, install, fit, maintain or use the system in accordance with the specifications and instructions provided by Rola.

For safety and use instructions, please refer to any General or Specific Fitting Instructions and Warning & Care Instructions enclosed within the system or on our website at www.rola.com.au.

This warranty does not extend to fair wear and tear. Warranty claims can be made by contacting Rola directly using the details below. A warranty claim must be accompanied by proof of purchase (such as receipt), details of the alleged defect and appropriate documentation (such as historical and maintenance records where appropriate). The customer must make the product available to Rola or its authorized repair agent for inspection and testing. If such inspection and testing finds no defect in the product, the customer must pay Rola usual costs of service work and testing. It is the purchaser's responsibility to arrange and pay to return the product or component to the place of purchase. The purchaser may seek reimbursement from Rola for the cost of such activities, providing Rola notifies the purchaser in writing that a warranty claim is justified. Any such claims made must be in writing via post or email.

The benefits of this warranty are in addition to any rights and remedies imposed by Australian State and Federal legislation that cannot be executed. Nothing in this warranty is to be interpreted as excluding, restricting or modifying any State or Federal legislation applicable to the supply of goods and services which cannot be so excluded, restricted or modified. Our goods come with guarantees that cannot be excluded under the Australian Consumer Law. You are entitled to a replacement or refund for a major failure and for compensation for any other reasonably foreseeable loss or damage. You are also entitled to have the goods repaired or replaced if the goods fail to be of acceptable quality and the failure does not amount to a major failure. Rola makes no express warranties or representations other than set out in this warranty.

SAFETY REQUIREMENTS

Manufactures roof weight limit - rack system weight = Max carrying capacity.

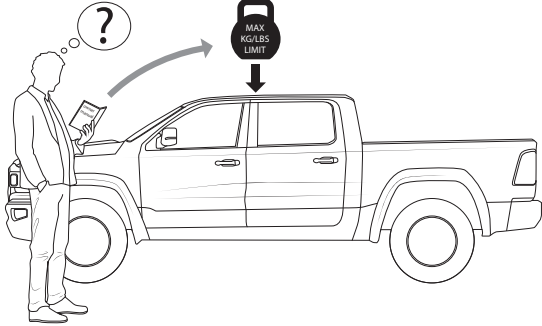

Cross reference with system max carrying capacity. **Always use the lower of the two figures.**

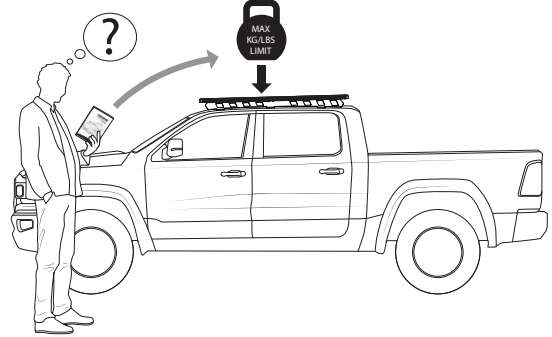

IMPORTANT - Off-road load rating reduction.

| System | Track Mount | Anchor Point | Gutter Mount | Raised Rail | Flush Rail | Clamp Mount |
|-----------------------|-------------|--------------|--------------|-------------|------------|-------------|
| Platform+ Ridge Mount | 0% | 0% | 25% | 0% | N/A | N/A |
| Platform+ Low Mount | 33% | 33% | 33% | 33% | 33% | 50% |
| Sports Extended | 33% | 33% | 33% | 33% | 33% | 50% |
| Sports Concealed | 33% | 33% | 33% | 33% | 33% | 50% |

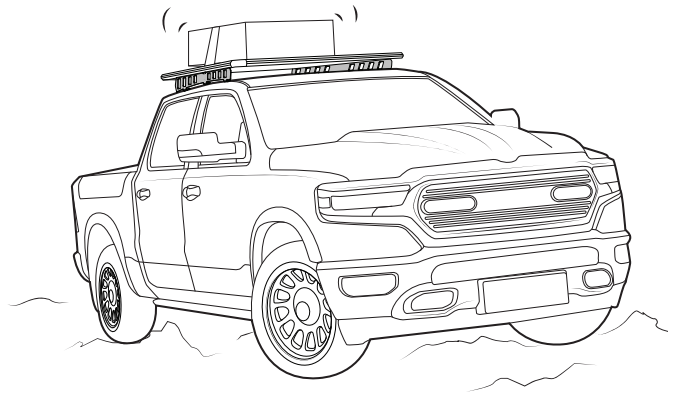

Distribute carried load evenly longitudinally and as low as possible. Do not concentrate loads front or rear.

CORRECT

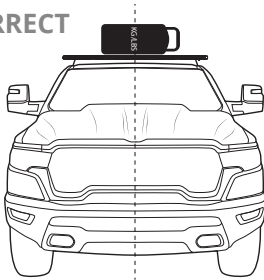

CORRECT

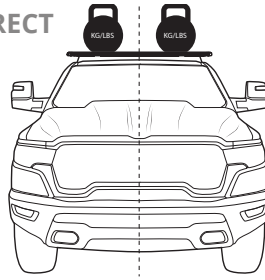

X

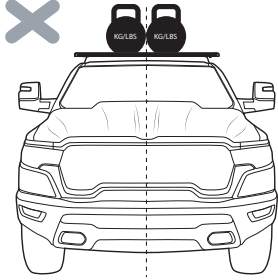

CORRECT

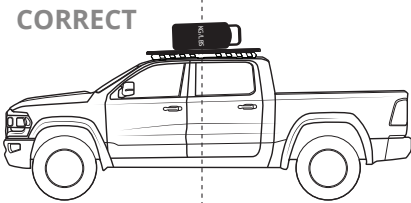

CORRECT

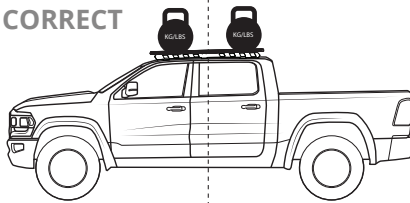

X

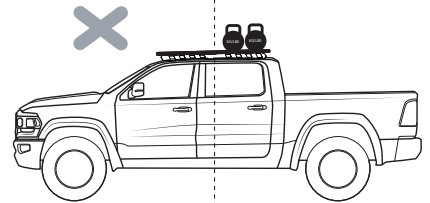

X

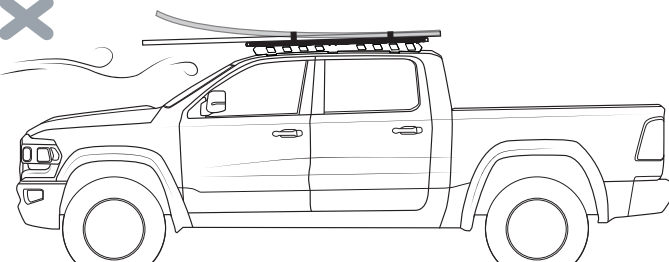

CORRECT

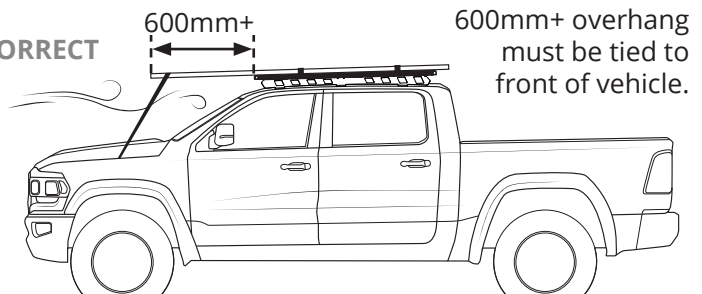

SAFETY REQUIREMENTS

