

RIDGE MOUNT

by **ROLA**

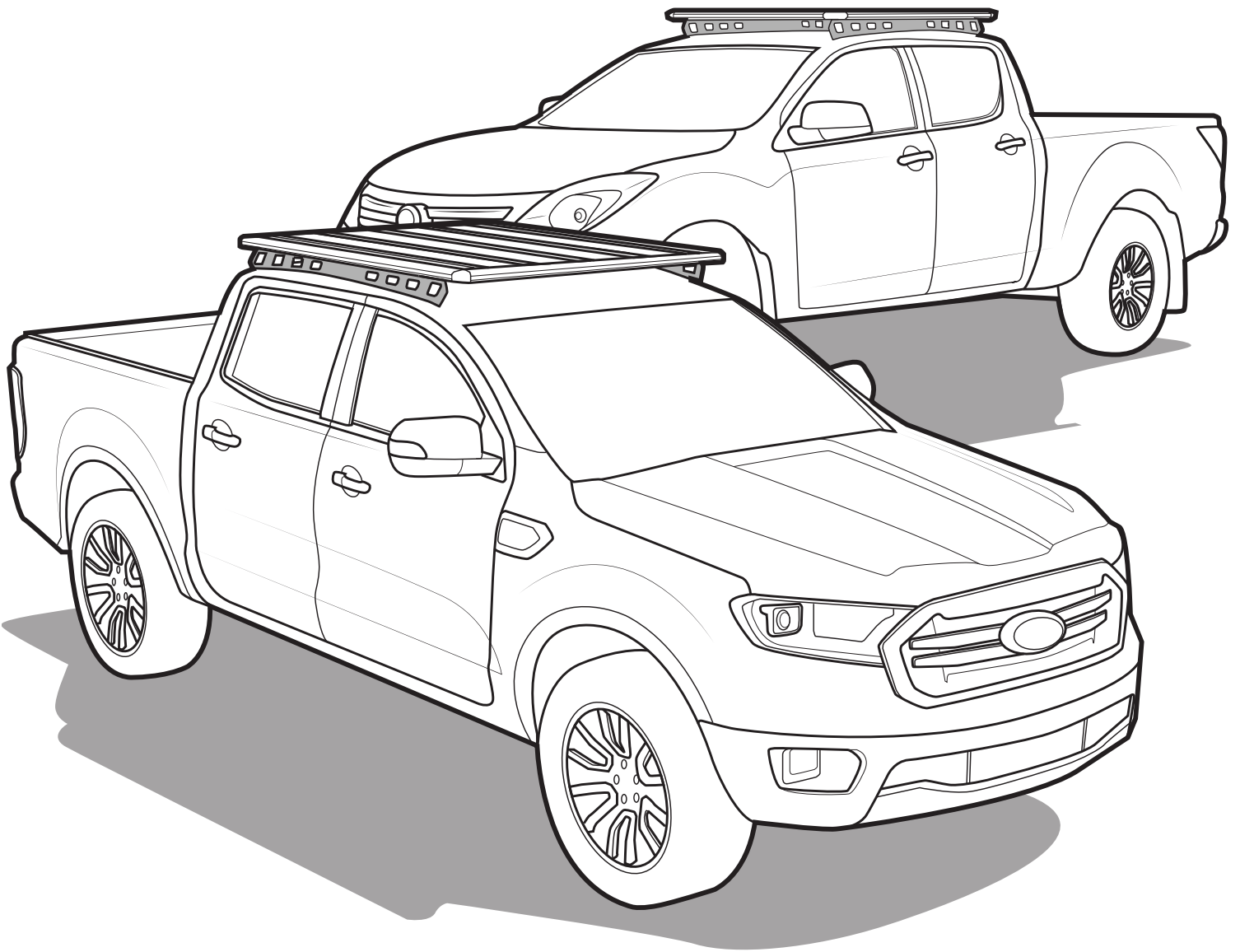

FORD RANGER PX3 09/11-on 4D UTE - RM36815
MAZDA BT50 GEN2 11-20 4D UTE - RM36817

RIDGE MOUNT SYSTEM
Issue 01

Read this full instruction prior to commencing assembly and fitment of Ridge Mount System.

CONTENT - CHECK ALL PARTS ARE CORRECT BEFORE PROCEEDING

A		Ranger Ridge Mount (pair)	1
B		Stud plate	4
C		M6x10mm Cap screw	8
D		M6 Spring washer	4
E		M6 Flat washer	8
F		M6 Nyloc nut	4
G		M8 Nyloc nut	16
H		Rola Tuff Anchor point	4
I		M6 Star washer	4
J		M8x17mm Flat washer	24
K		M8x25mm Cap screw	8
L		Interlocking Block	3
M		Brass nut	8

TOOLS REQUIRED

- 5mm allen tool.
- 13mm + 10mm socket wrench.
- Step ladder.
- Butyl mastic sealant.
- Vacuum.
- Cold galvanising paint.
- 6.5mm drill bit.
- 11mm drill bit.
- Power drill.

1

Move to the side of the vehicle. Use a step ladder to get access to the vehicle.

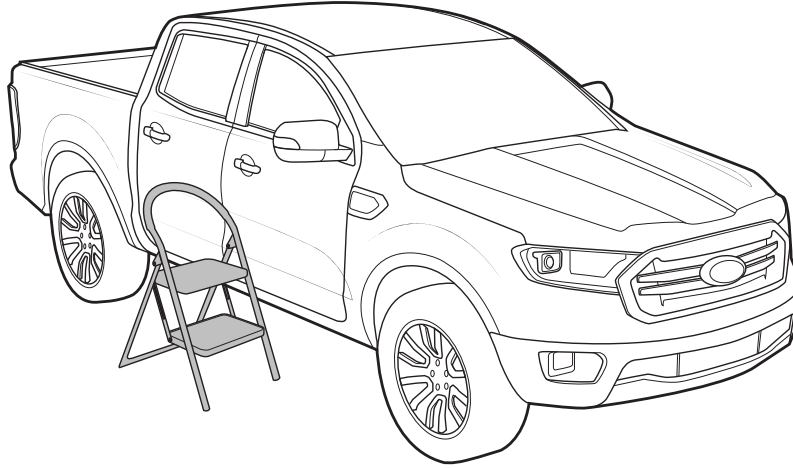

FOR ANCHOR POINT INSTALLATION AND MOUNTING

2

Measure forward from the B-pillar 210mm and rearward 540mm. Create references at these points with a marker on the weather strip.

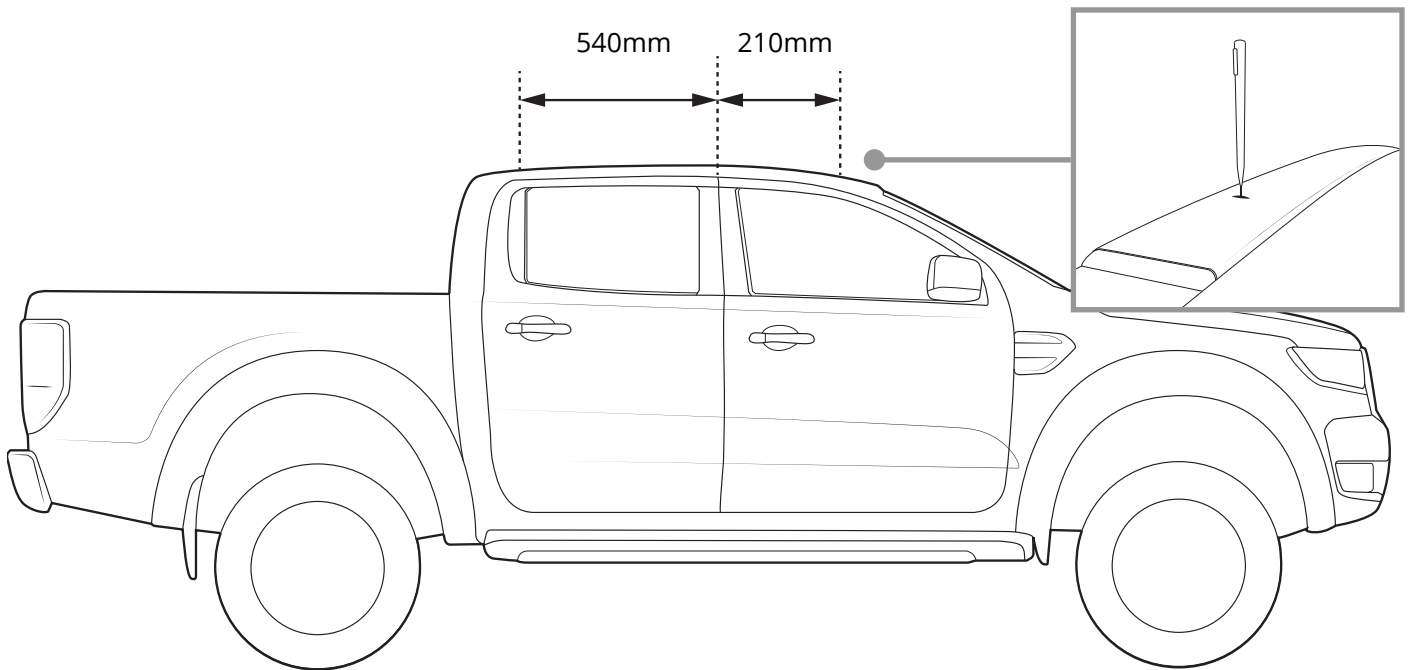

3

Carefully drop the hood liner as per Ford factory instructions.

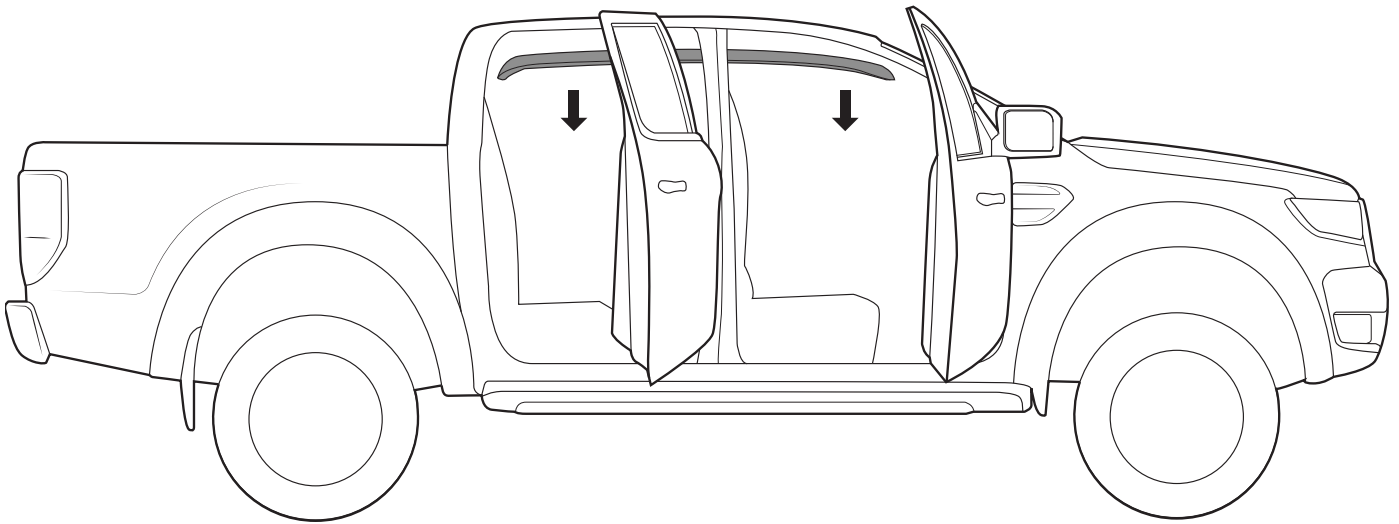

4

Pilot drill a 6mm diameter hole through the weather strip and roof sheet at the references made in step 2. Use a drill stop set to 10mm to ensure airbags are not damaged under the roof sheet.

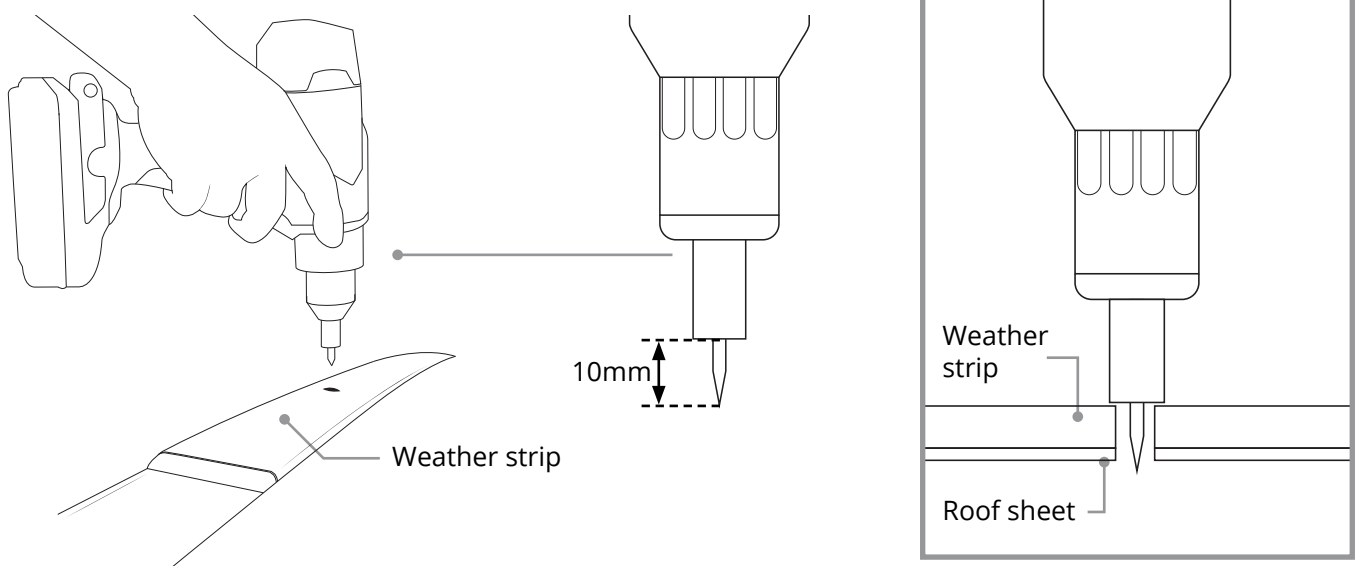

5

Use a 11mm drill bit and open up the hole in the weather strip made previously. Do not drill through the sheet metal. Using a drill stop and incrementally increasing depth will ensure roof sheet will be protected.

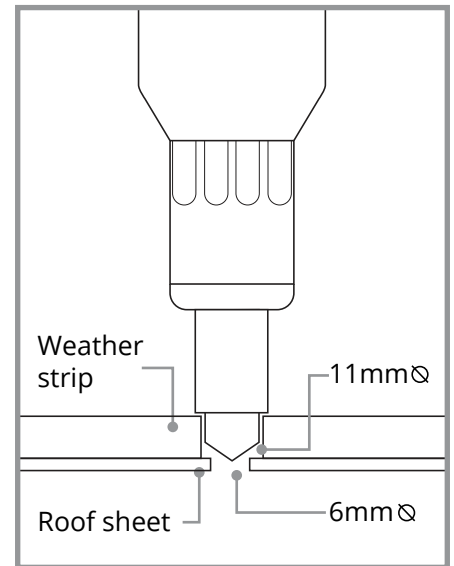
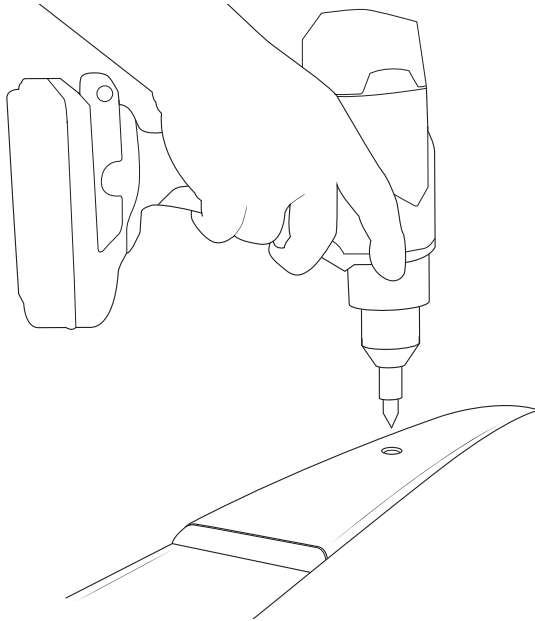

6

Vacuum any swarf from the vehicle. Apply cold galvanising paint to any exposed bodywork. Allow time to dry as per specifications on container.

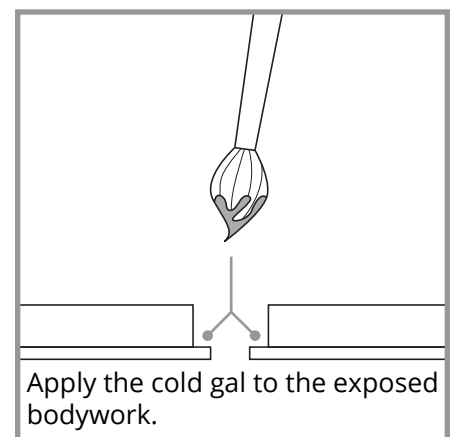
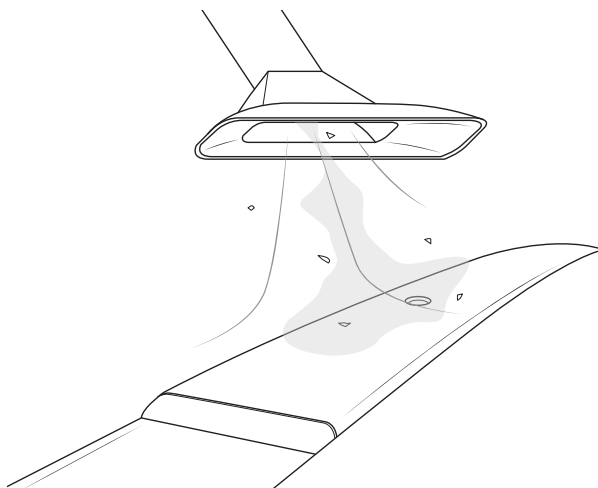

7

Apply butyl mastic to the anchor bolt and star washer as shown. Carefully insert the assembly into the holes drilled.

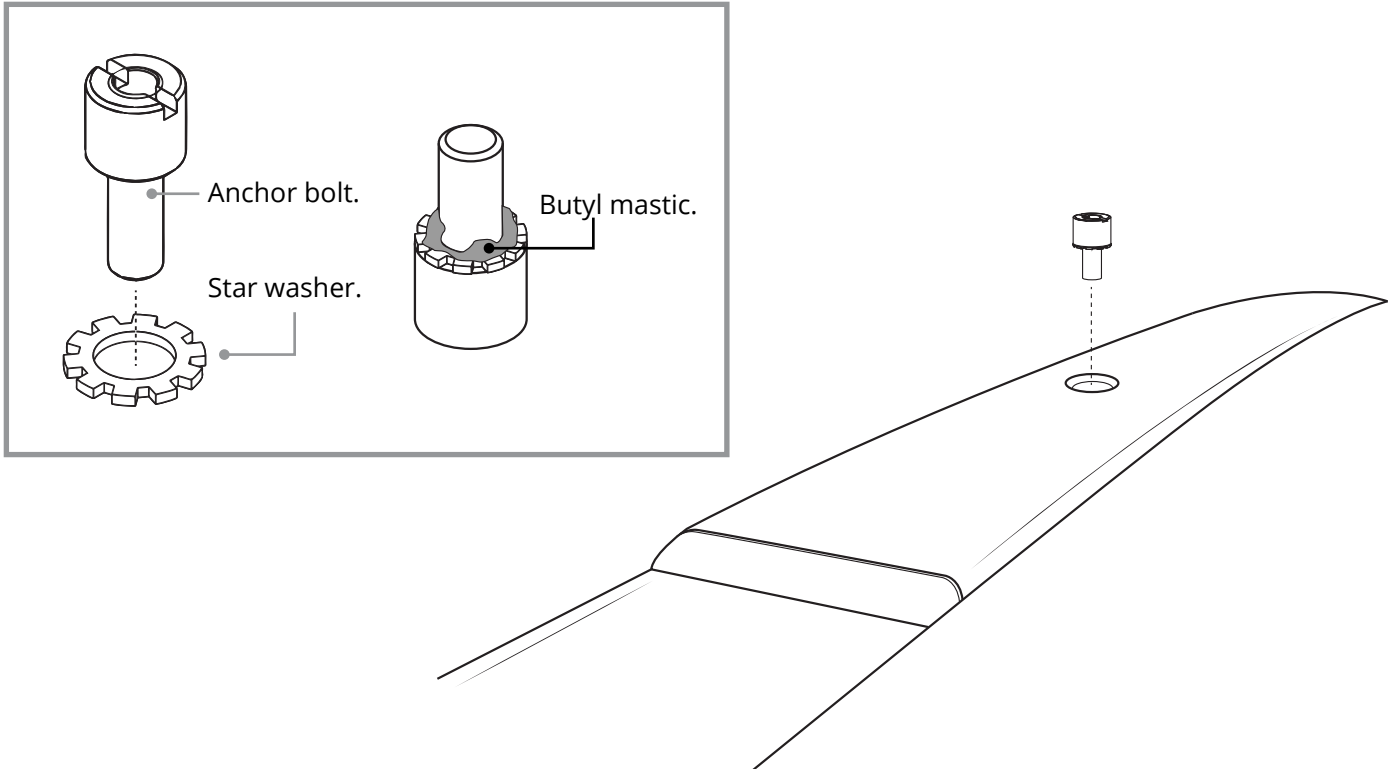

8

Hold the anchor bolt in place with a wide flat head screwdriver and secure with an M6 nyloc nut, using a 10mm socket.

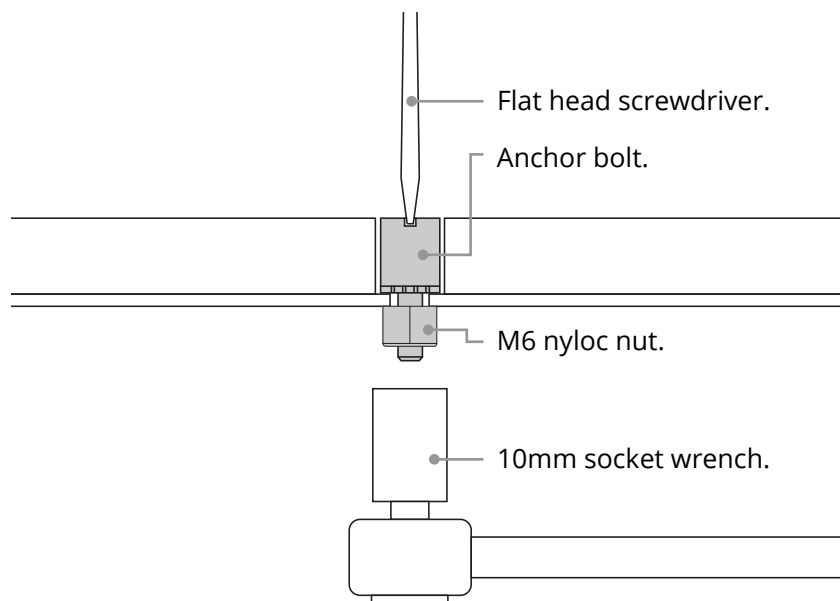

Note: Repeat steps 4 to 8 on all points referenced in step 2.

9

Replace the headline back into its original position.

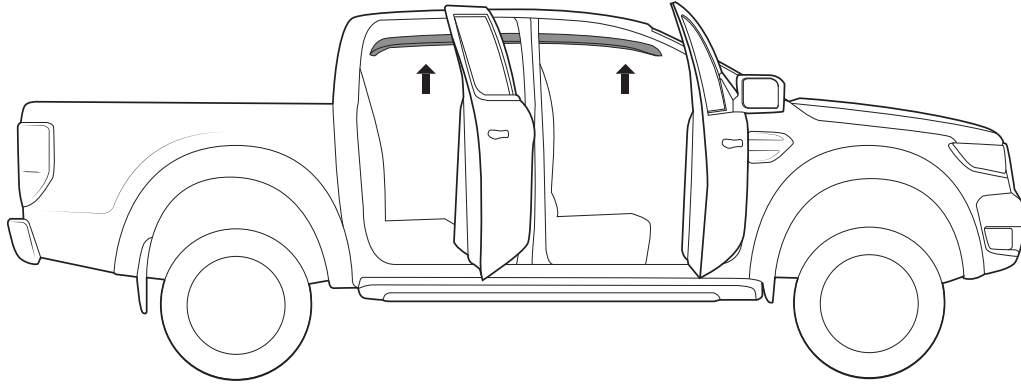

10

Assemble M6 hardware into the Ridge Mount Rails as shown. Be aware of correct mount points in rail feet.

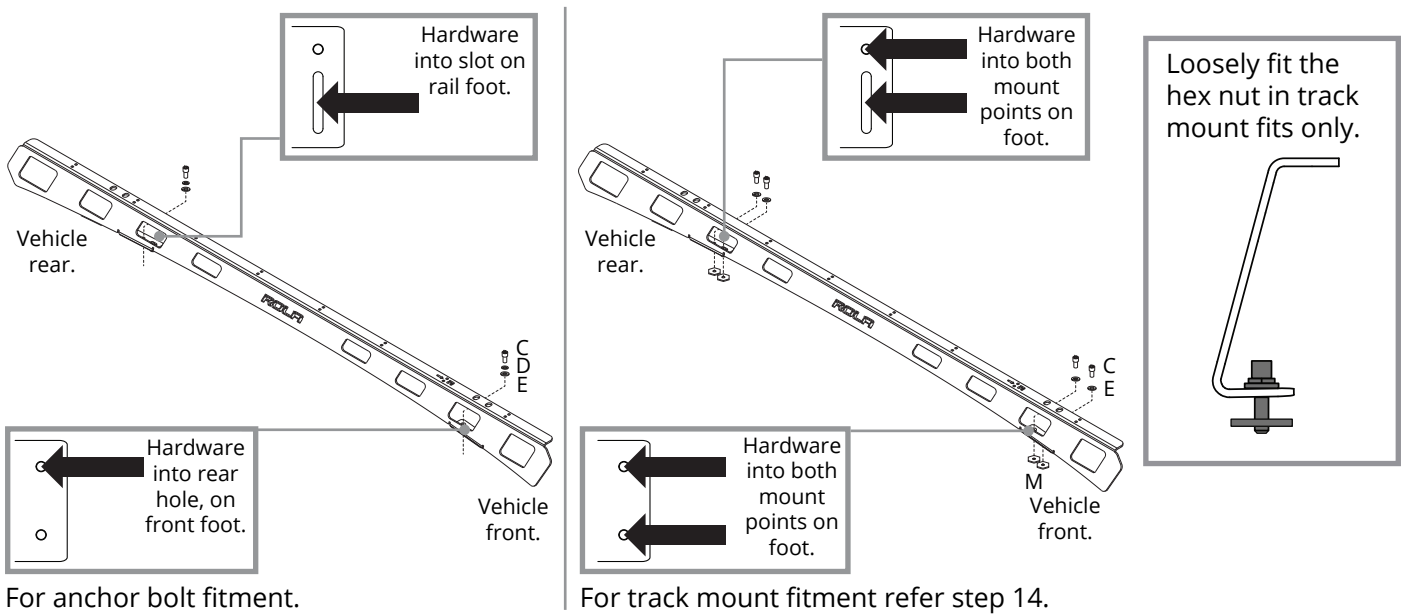

11

Install the stud plates as shown.

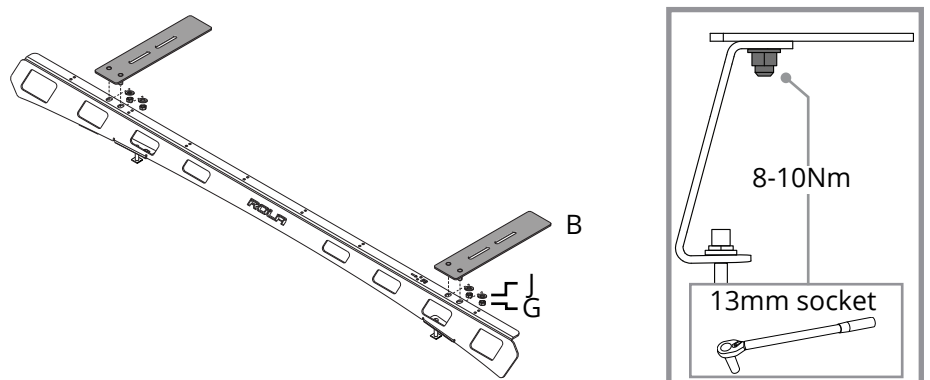

12

Place the Ridge Mount assembly onto the roof. The M6 hardware will pick up the anchor bolts installed into the roof.

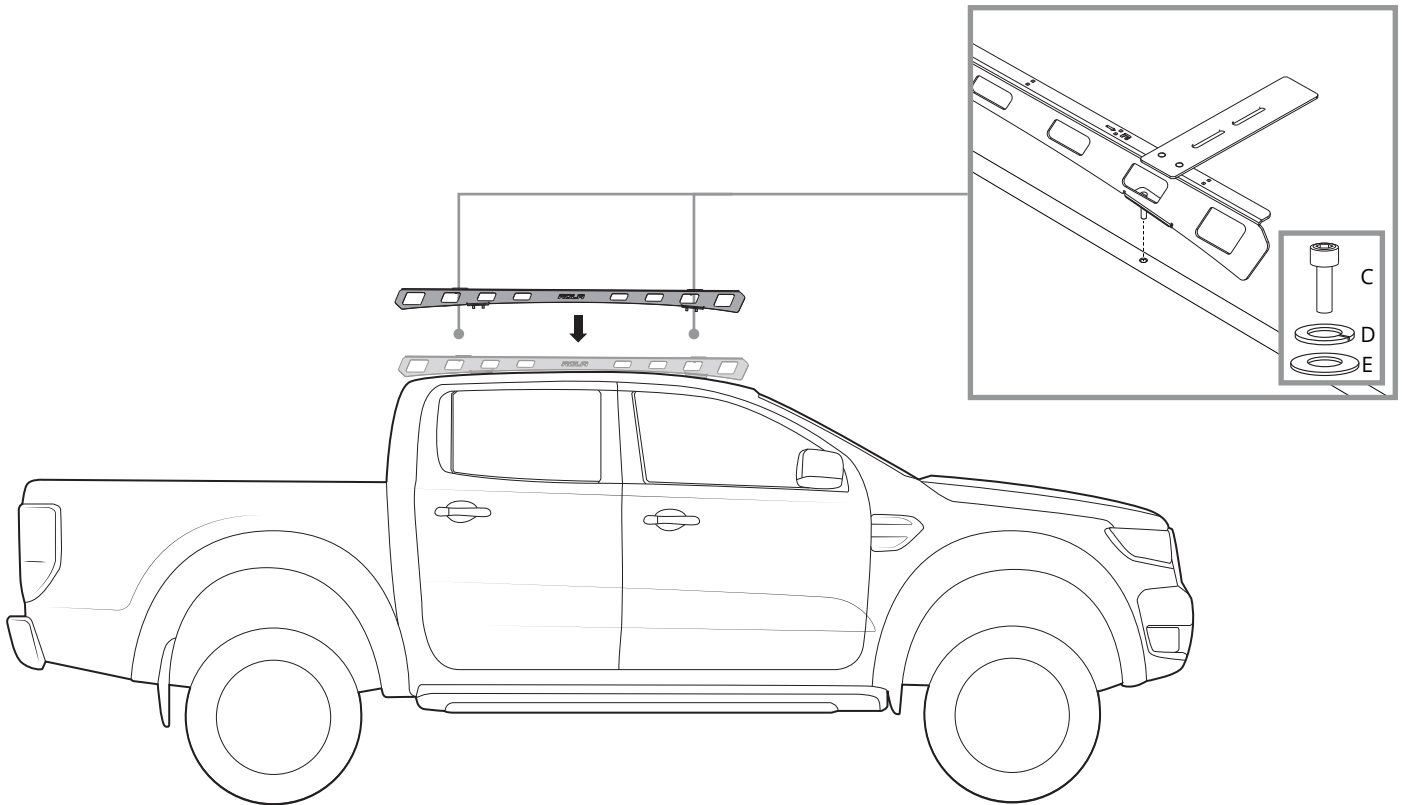

13

Tighten the M6 hardware with a 5mm allen key to 4-5Nm.
Note: Access hardware through cutouts on side of the rail.

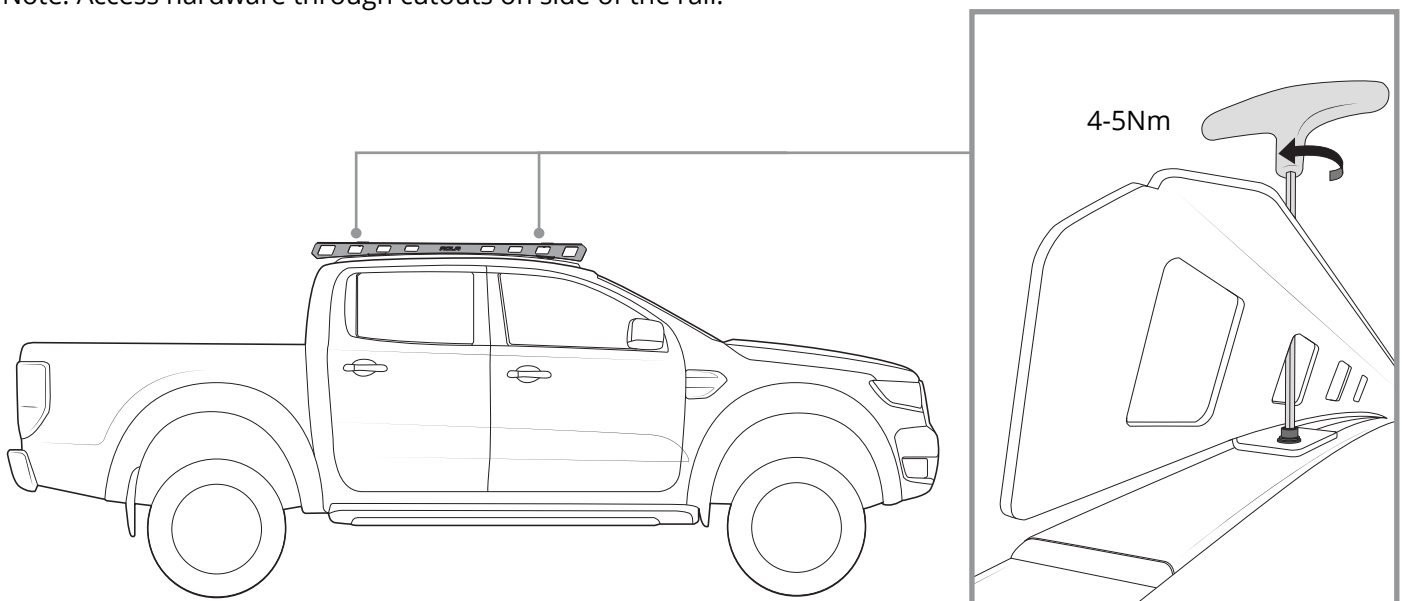

FOR TRACK MOUNT FITMENT

14

Drop the fitted square nuts into the accessory port on the pre-installed tracks of the vehicle.

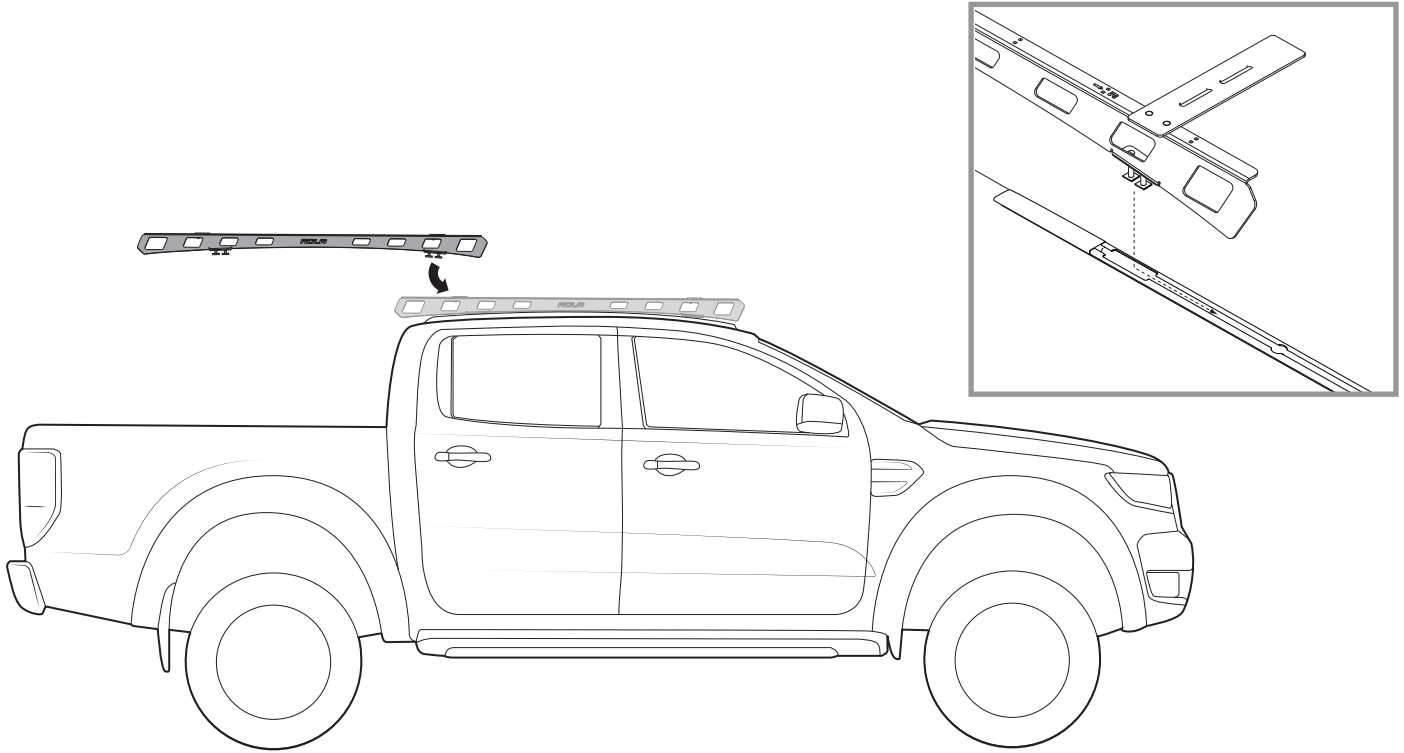

Note: Due to variants in track fitments, exact accessory port position could change.

15

Using a 5mm allen key, tighten the M6 hardware, fixing the Ridge Mounts in place.

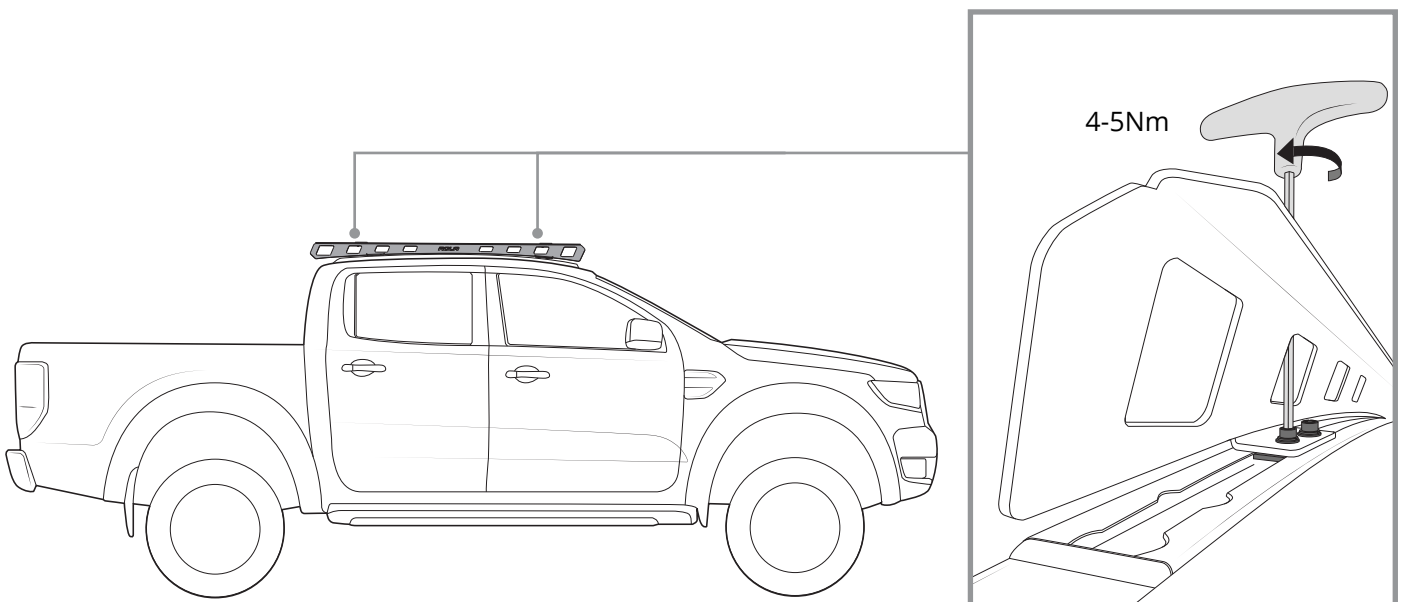

TITAN TRAY FITMENT

16

Install the Rola Titan Tray as per corresponding instructions.

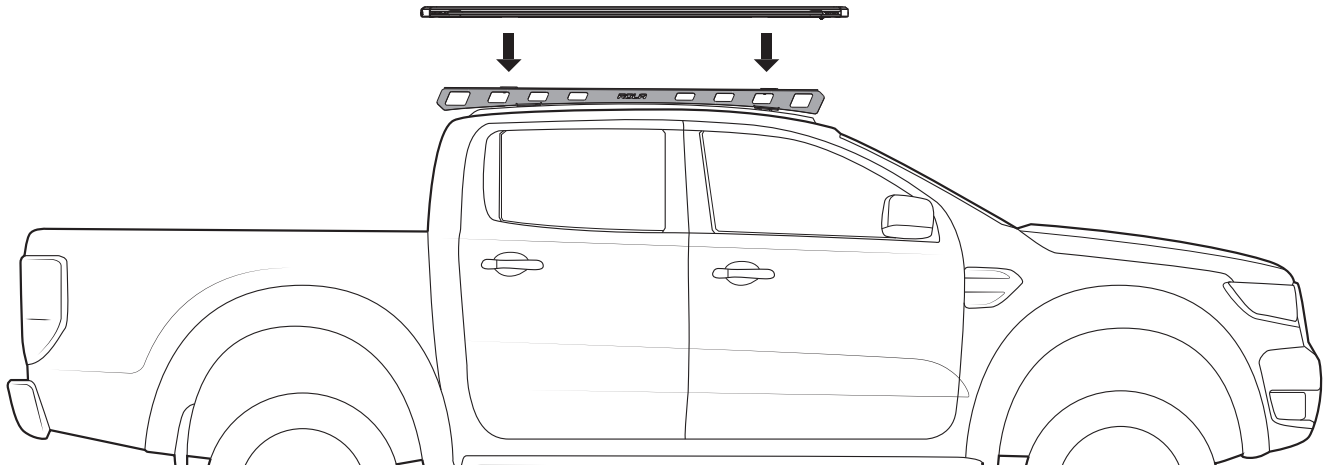
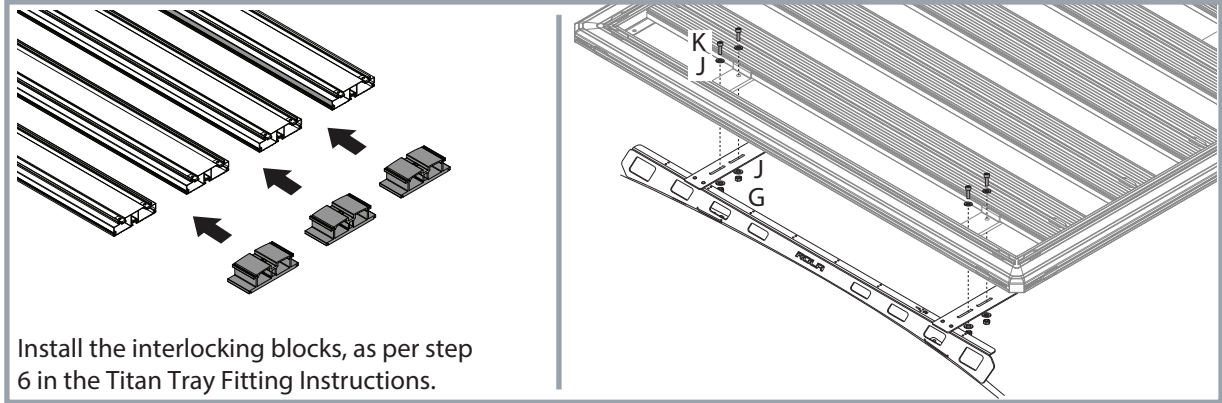

Note:

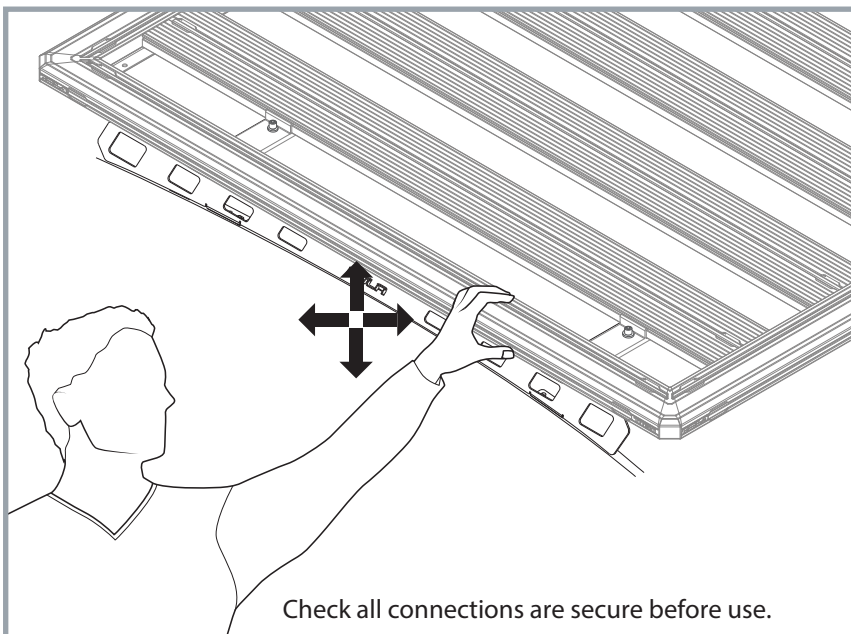

Wiring can be run and secured on the underside of the Ridge Mount rail as shown.

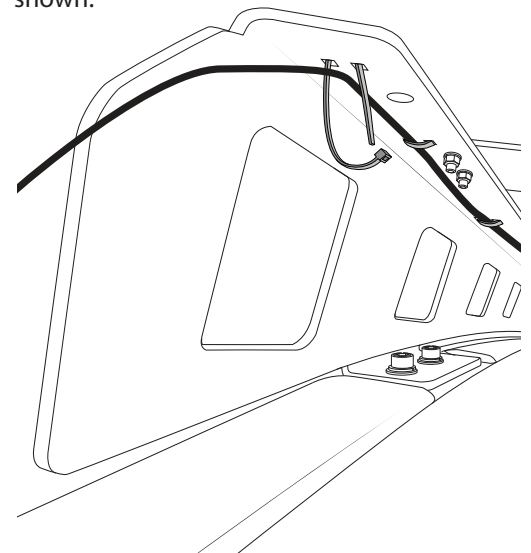

IMPORTANT - READ BEFORE USE

Please ensure the system is fitted in accordance with the fitting instructions. It is important that you observe all outlined below.

**LOAD RECOMMENDATIONS**

- Routinely and regularly check the proper functioning of the system. Check all fixtures at regular intervals.
- Do not use an automatic carwash with system installed.
- Maximum load capacity of the system is 300kg under static conditions.
- Maximum load capacity of the system is 100kg under dynamic including off-road conditions.
- Do not exceed vehicle manufacturers recommended load rating if it is lower than the maximum load capacity specified in this document (i.e., 100kg).
- Ensure any load carried is evenly distributed.
- Actual load on vehicle Roof (Refer to owner's manual) = Weight of Roof rack system / Ridge Mount + Weight of Tray + Weight of cargo.
- Actual load on rack system (Refer to product instructions) = Tray weight + cargo.

WARRANTY INFORMATION

Rola warrants that, subject to exclusions and limitations below, the Ridge Mount system will be free from defects in materials and workmanship for a period of 5 years commencing on the date of sale by the authorized Rola stockist to the original purchaser of the system.

If a defect appears in the Ridge Mount system before the end of the warranty period and Rola finds that the defect is in materials or workmanship, Rola will, in its sole discretion, either:

1. Repair the Ridge Mount or the defective component of the Ridge Mount system free of charge
2. Replace the Ridge Mounts or the defective component of the Ridge Mount system; or
3. Refund the purchase price of the Ridge Mount system to the original purchaser.

Rola reserves the right to change the design, specifications or composition of the Ridge Mount system without notice and without liability.

Rola reserves the right to replace defective products or components with products or components of similar quality, grade and composition, where an identical product or component is not available. Goods presented for repair may be replaced by refurbished goods of the same type rather than being repaired. Refurbished parts may be used to repair the goods.

The 5 year warranty does not apply where:

1. The Ridge Mount system is not installed in compliance with the fitting instructions provided
2. The Ridge Mount system is not used as intended or designed
3. Any part of the Ridge Mount system is used with other products or components not intended to be used in conjunction with the Ridge Mount system
4. The Ridge Mount system has been on-sold or assigned by the original purchaser
5. The Ridge Mount system has been modified or repaired by someone other than Rola or an authorized Rola stockist
6. Rola cannot establish any fault after inspection of returned product
7. The Ridge Mount system has been subject to abnormal conditions, including fire, water, humidity, pressure, stress or similar
8. The defect in the Ridge Mount system has arisen due to abuse, misuse, neglect or accident
9. The defect in the Ridge Mount system has arisen due to the unlawful or unusual operation of the vehicle to which it is fitted
10. The defect in the Ridge Mount system has arisen due to the purchaser's failure to properly assemble, install, fit, maintain or use the Ridge Mount system in accordance with the specifications and instructions provided by Rola.

For safety and use instructions, please refer to any General or Specific Fitting Instructions and Warning & Care Instructions enclosed within the Ridge Mount system or on our website at www.rola.com.au.

This warranty does not extend to fair wear and tear. Warranty claims can be made by contacting Rola directly using the details below. A warranty claim must be accompanied by proof of purchase (such as receipt), details of the alleged defect and appropriate documentation (such as historical and maintenance records where appropriate). The customer must make the product available to Rola or its authorized repair agent for inspection and testing. If such inspection and testing finds no defect in the product, the customer must pay Rola usual costs of service work and testing. It is the purchaser's responsibility to arrange and pay to return the product or component to the place of purchase. The purchaser may seek reimbursement from Rola for the cost of such activities, providing Rola notifies the purchaser in writing that a warranty claim is justified. Any such claims made must be in writing via post or email.

The benefits of this warranty are in addition to any rights and remedies imposed by Australian State and Federal legislation that cannot be executed. Nothing in this warranty is to be interpreted as excluding, restricting or modifying any State or Federal legislation applicable to the supply of goods and services which cannot be so excluded, restricted or modified. Our goods come with guarantees that cannot be excluded under the Australian Consumer Law. You are entitled to a replacement or refund for a major failure and for compensation for any other reasonably foreseeable loss or damage. You are also entitled to have the goods repaired or replaced if the goods fail to be of acceptable quality and the failure does not amount to a major failure. Rola makes no express warranties or representations other than set out in this warranty.