



FITTING INSTRUCTIONS



PRODUCT :

PIAK GENESIS LOOP WINCH BAR

VEHICLE MODEL :

TOYOTA LANDCRUISER PRADO 250

PRODUCT PART NUMBER :

PK105P250G_RBO_URPMB
PK105P250G_RBO_URPBO

PK105P250G_RMB_URPMB
PK105P250G_RMB_URPBO

FITTING TIME :

Approx. 3 hours

TABLE OF CONTENTS

Page

Tools Required	5
Part List	5
Component Overview	10
Toque Setting of Fastener	10
Fitting Procedure	11

BULL BAR SAFETY NOTICE :

INSTALLATION SHOULD ONLY BE DONE BY APPROPRIATELY QUALIFIED OR EXPERIENCED PERSONS IN ACCORDANCE WITH THESE INSTRUCTIONS.

IT IS THE RESPONSIBILITY OF THE INSTALLER TO ENSURE THAT THE PRODUCT IS CORRECTLY FITTED.

WARNING :

Do not attach Vehicle Frontal Protection System (VFPS) to the vehicle using anchorages not intended for this purpose. (e.g. engine mounting bolts)

Do not use this product for any vehicle make or model, other than those specified by the VFPS manufacturer.

Do not remove the plaque or label from the VFPS.

Do not modify the structure of the VFPS in any way.

The VFPS has been produced to provide continued functionality of parking sensors and other "driver assist" features as closely as possible to Original Equipment. However, as all possible road conditions and combination of other accessories fitted to the vehicle which may affect functionality characteristics cannot be anticipated, **the driver remains responsible at all times for properly controlling the vehicle, monitoring all "driver assist" features and intervening where required to ensure the vehicle is safely operated.**

IMPORTANT INFORMATION :

Before installing the VFPS :

Check that all components, as listed in the assembly table, are available.

Thoroughly read all instructions.

This product or its fasteners must not be modified in any way.

These instructions are accurate as at the revision date and do not take into account any changes made by the vehicle manufacturer to vehicle design after the revision date or other accessories that are or have been fitted to the vehicle. Piak cannot be held responsible for such changes and appropriate enquiries should be made before installation.

Before installing, inspecting and/or maintaining the VFPS, the work space should be safe and clear of fuel, debris, electrical or other components.

During installation :

It is the responsibility of the installer to confirm correct operation/clearance of all components. All holes drilled shall have all burrs and swarf removed then coated with a suitable rust preventative paint.

Ensure that all hardware is fastened to torque list as detailed in these instructions.

MAINTENANCE AND CARE :

To ensure continued safety and correct operation of the product, the VFPS must be routinely inspected and regularly serviced (including bolt torque checked for correct tension) by an appropriately qualified or experienced person.

The high tensile fasteners supplied with this product were used to achieve the specified rating. If replacement of the fasteners is required, fasteners of the same rating and quality must be used.

If this VFPS is fitted with a hinged number plate bracket, extra care must be taken when returning back to public roads following the use of the winch or conducting a deep water crossing.

The driver must ensure that the number plate bracket is returned back to the down position allowing full visibility of the number plate when returning to public roads.

EQUIPMENT :

These safety products should, at a minimum, be used when fitting or working on the product.



Protective Glasses



Hearing Protection

Installation in accordance with these instructions and adherence to warnings will ensure compliance with relevant regulatory and safety standards as at the revision date.

Failure to adhere to these instructions may affect the roadworthiness of the vehicle or cause personal injury, death or damage to property.

BY USING THIS PRODUCT YOU ACKNOWLEDGE AND AGREE THAT TO THE EXTENT PERMITTED BY LAW PIAK WILL NOT ACCEPT LEGAL OR OTHER LIABILITY FOR ANY LOSS, INJURY OR DAMAGE CAUSED BY INCORRECT OR INAPPROPRIATE INSTALLATION OR USE OF THE PRODUCT.

TOOLS REQUIRED

- | | | |
|--------------------------------|-----------------------------|---------------------------------------|
| 1. Metric Socket and Spanners | 2. 2" Masking tape | 3. Marking pen |
| 4. Drill and metric drill bits | 5. Test lamp or multi-meter | 6. Phillip and flat head screw driver |
| 7. Torque wrench | 8. Air saw | |

PART LIST

Important : Check contents of fitting kit before commencing fitment and report any discrepancies.

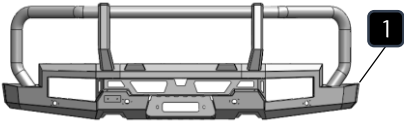
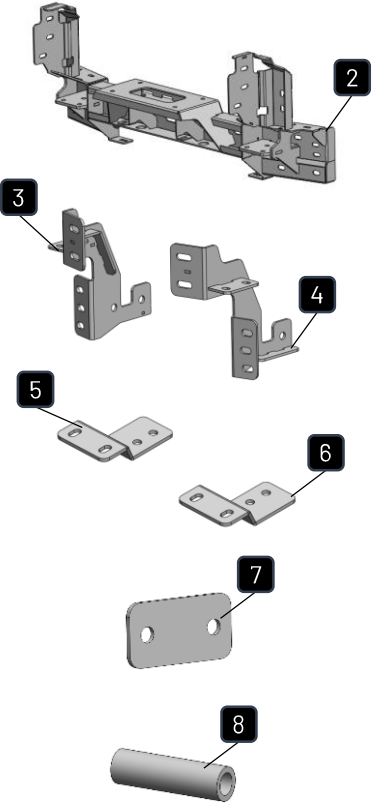
STEEL BULL BAR			
ITEM	COMPONENT NAME	Q'ty	REMARKS
1	PIAK Genesis Loop Bar	1	
MOUNTING BRACKET			
ITEM	COMPONENT NAME	Q'ty	REMARKS
2	Mounting Bracket	1	
3	Chassis Support RH	1	
4	Chassis Support LH	1	
5	Chassis Support Bottom RH	1	
6	Chassis Support Bottom LH	1	
7	Tube OD19x68 mm.	4	
8	Plate 4 mm.	2	
9	Hex Bolt M12x1.25x100	4	
10	Spring Washer M12	4	
11	Flat Washer M12	8	
12	Hex Nut M12x1.25	4	
13	Hex Bolt M10x35x1.5 EDP	18	
14	Spring Washer M10 EDP	18	
15	Flat Washer M10 EDP	34	
16	Hex Nut M10x1.5 EDP	18	
17	Hex Bolt M12x30x1.25	4	
18	Spring Washer M12	4	
19	Flat Washer M12	4	
20	Hex Bolt M10x35x1.5	4	
21	Spring Washer M10	4	
22	Flat Washer M10	8	
23	Hex Nut M10x1.5	4	

PART LIST

RECOVERY POINT

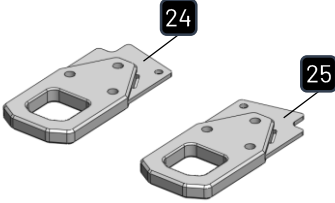
ITEM	COMPONENT NAME	Q'ty	REMARKS
24	Recovery Point RH	1	
25	Recovery Point LH	1	
26	Hex Bolt M12x1.5x50 Gr10.9 EDP	6	
27	Spring Washer M12 EDP	6	
28	Flat Washer M12 EDP	12	
29	Hex Nut M12x1.5 Gr10.9 EDP	6	

BAR TO MOUNTING BRACKET

ITEM	COMPONENT NAME	Q'ty	REMARKS
30	Hex Bolt M12x1.5x35	6	
31	Spring Washer M12	6	
32	Flat Washer M12	12	
33	Hex Nut M12x1.5	6	
34	Hex Bolt M10x1.25x35	4	
35	Spring Washer M10	4	
36	Flat Washer M10 OD20	8	
37	Flange Nut M10x1.25	4	

RADIATOR PLATE

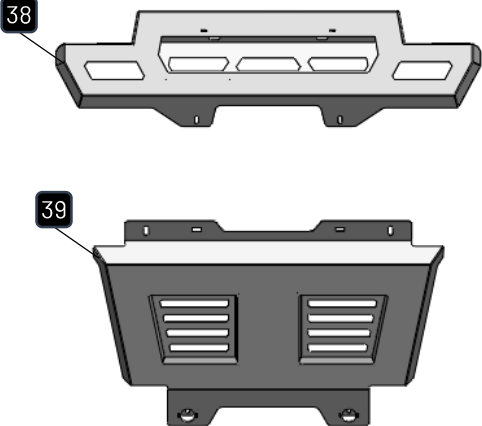
ITEM	COMPONENT NAME	Q'ty	REMARKS
38	Radiator Plate Top	1	
39	Radiator Plate Bottom	1	
40	Hex Bolt M8x30x1.25 EDP	4	
41	Spring Washer M8 EDP	4	
42	Flat Washer M8 EDP	4	
43	Cage Nut M8x1.25x3.2T	4	
44	Hex Bolt M8x30x1.25	2	
45	Spring Washer M8	2	
46	Flat Washer M8	2	
47	Hex Bolt M10x30x1.5	2	
48	Spring Washer M10	2	
49	Flat Washer M10	2	
50	Cage Nut M10x1.5x4T	2	

PART LIST

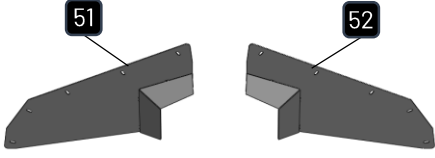
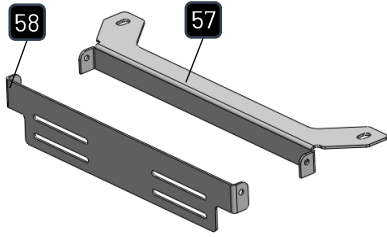
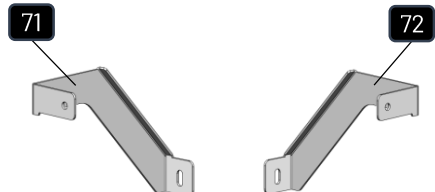
SIDE PLATE			
ITEM	COMPONENT NAME	Q'ty	REMARKS
51	Side plate RH	1	
52	Side plate LH	1	
53	Hex Bolt M6x20x1.0	10	
54	Spring Washer M6	10	
55	Flat Washer M6	10	
56	Cage Nut M6x1.0x3T	10	
LICENSE PLATE BRACKET			
ITEM	COMPONENT NAME	Q'ty	REMARKS
57	License Plate Bracket _Inner	1	
58	License Plate Bracket _Outer	1	
59	Hex Bolt M6x20x1.0 EDP	2	
60	Spring Washer M6 EDP	2	
61	Flat Washer M6 EDP	4	
62	Flange Nut M6x1.0 EDP	2	
63	Button Head Bolt M6x20x1.0 SUS	2	
64	Flat Washer M6 OD14 SUS	4	
65	Nylon Washer M6	4	
66	Nyloc Nut M6x1.0 SUS	2	
67	Hex Bolt M8x30x1.25	2	
68	Spring Washer M8	2	
69	Flat Washer M8	4	
70	Flange Nut M8x1.25	2	
FRONT GRILL BRACKET			
ITEM	COMPONENT NAME	Q'ty	REMARKS
71	Front Grill Bracket RH	1	
72	Front Grill Bracket LH	1	
73	Hex Bolt M6x1.0x20	4	
74	Spring Washer M6	4	
75	Flat Washer M6	6	
76	Flange Nut M6x1.0	2	

PART LIST

ACCESSORIES			
ITEM	COMPONENT NAME	Q'ty	REMARKS
77	Cable Tie (L=150 mm)	15	
78	Electro Tap	6	
79	Sensor blanking plugs	4	
80	Sensor Housing	4	
81	Cable Tie Mount	5	
82	Pinch weld rubber seal L180mm.	2	

** Refer to the Wiring Harness (PK105P250G-WL) installation manual for wiring harness installation instructions.

COMPONENTS OVERVIEW

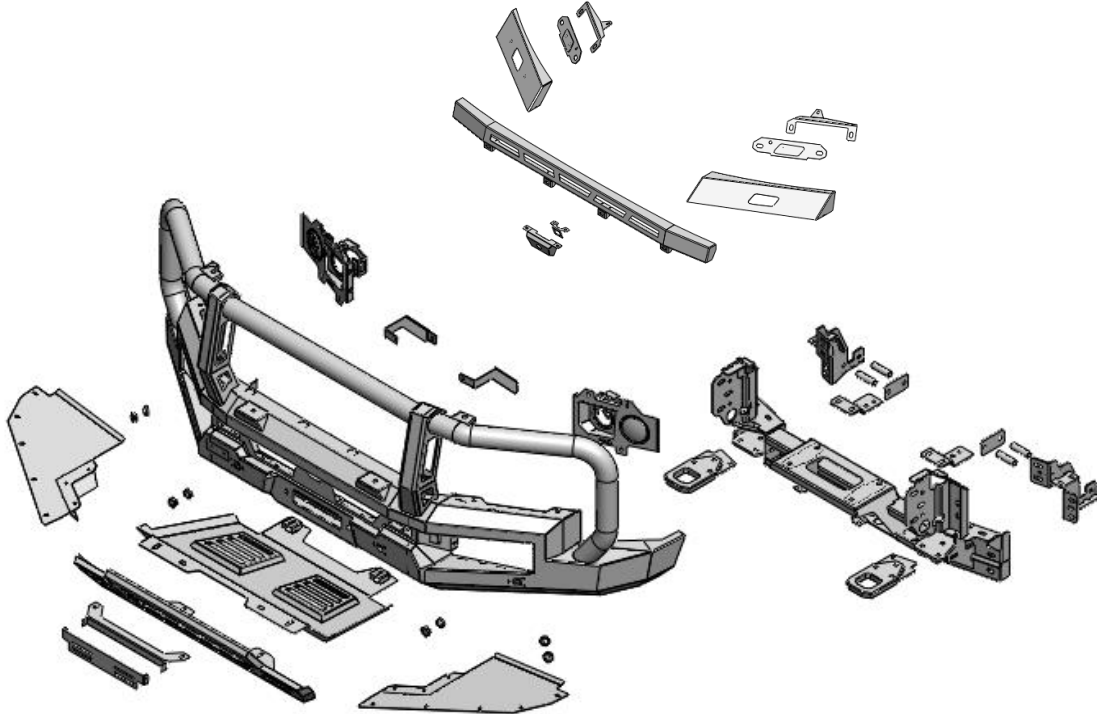

TORQUE SETTING OF FASTENER

Mounting bolts must be tightened to torque's specified following ;

Bolt Diameter (mm.)	Class 8.8		Class 10.9	
	Torque (Nm.)	Torque (ft-lb.)	Torque (Nm.)	Torque (ft-lb.)
M6	10.5	7.7	15	11.1
M8	25.5	18.8	36.5	26.9
M10	50.5	37.2	72.2	53.3
M12	88	64.9	126	92.9
M14	140	103	200	148

FITTING PROCEDURE

- 01** Locate the vehicle in a suitable position.



- 02** Mask both sides with tape as shown in the picture, aligning it with the factory flare. Make sure to follow the alignment directions and refer to the lines on the side of the car to ensure accurate positioning.

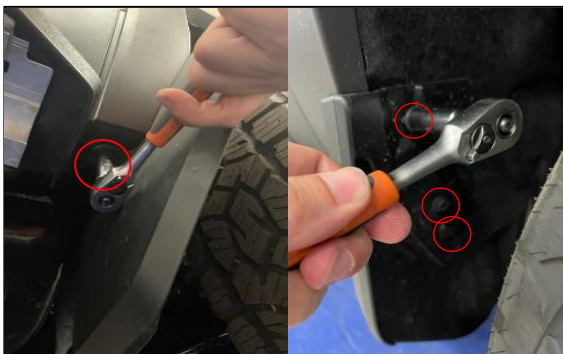

- 03** **Remove Front Mudflaps.**

Remove 3 x 10mm screws and 1 x Plastic Rivet from Mudflap and set aside. Remove Mudflap and set aside. Repeat process for other side



- 04** **Remove Front Mudflaps.**

Remove Mudflap and set aside. Repeat process for other side

FITTING PROCEDURE

**05 Remove lower front air deflectors**

Remove 3 x 10mm screws and 3 x Plastic Rivet from air deflector and set aside.

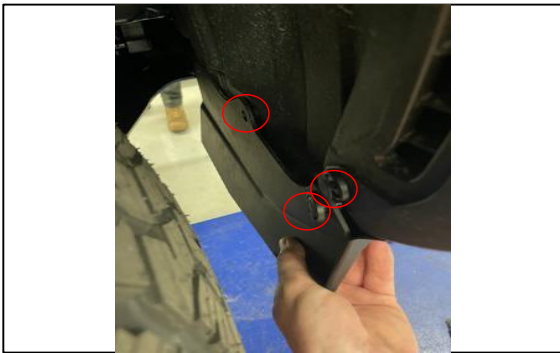
**06 Remove lower front air deflectors**

Remove air deflector and set aside. Repeat process for other side

**07 Over-fender Flare Removal**

Remove 1 x 10mm Screw and 6 x plastic inside wheel arch.

**08 Over-fender Flare Removal**

Remove flare by starting at 1 end and pull directly outwards from the body of the vehicle. Repeat process for other side

Cut the flares along the marked cutting line using an air saw or a similar tool.

Clean up the trimmed edges to ensure a smooth and finished appearance.

FITTING PROCEDURE

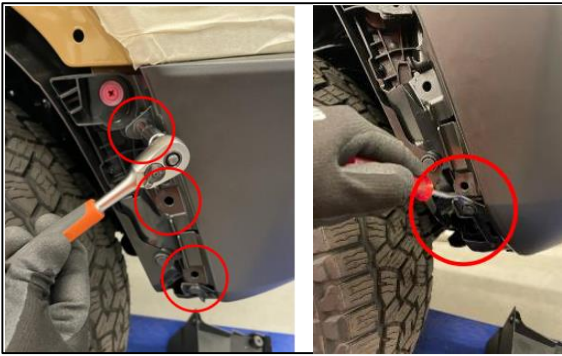
**09 Bumper Removal (Bumper Ends)**

Remove 3 x 10mm screws and 1 x plastic rivet from behind the removed flare. Repeat process for other side.

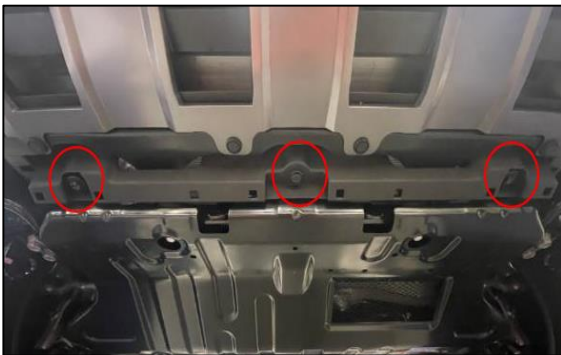
**10 Bumper Removal (Lower Bumper Fasteners)**

Remove 2 x 10mm bolts and 1 x plastic rivet on underside of OE bumper. Remove lower bumper trim

**11 Bumper Removal (Lower Bumper Fasteners cont)**

Remove 4 x 10mm bolts on bottom of OE bumper.

**12 Upper Grille Fasteners.**

Removing 3 x 10mm bolts. Lift 2x outer tabs gently off the retaining pins on the brackets under the 2x outer tabs.

FITTING PROCEDURE

**13 Bumper Release 1.**

Release the bumper by pressing the tabs on the clips, located on the inside of the grill

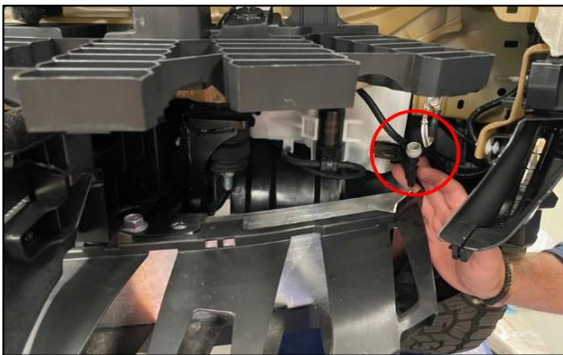
**14 Bumper disconnection.**

Place a bucket or similar vessel in front of LH front wheel, under the bumper to catch washer fluid. Disconnect headlight washer line on inside of bumper.

***bumper removed for clarity.

**15 Bumper disconnection cont.**

- Disconnect primary vehicle battery under bonnet.
- Disconnect electrical connector for lights on front RH side of vehicle.
- Disconnect electrical connector for driver assist sensors.

***bumper removed for clarity

**16 Bumper disconnection cont.**

DO NOT TURN VEHICLE ON. ENSURE KEY IS SECURE AND THE IGNITION CANNOT BE TURNED ON FROM THIS POINT. IF THE VEHICLE IS TURNED ON, THE VEHICLE IS AT RISK OF HAVING MAJOR ELECTRICAL FAULTS THAT WILL REQUIRE TOYOTA DEALERSHIP REPAIR.

FITTING PROCEDURE

**17 Bumper Removal.**

Release the bumper clips in front of the wheel arch by pulling forwards and outwards. Remove clips under the headlamps by pulling the bumper towards the front of the vehicle.

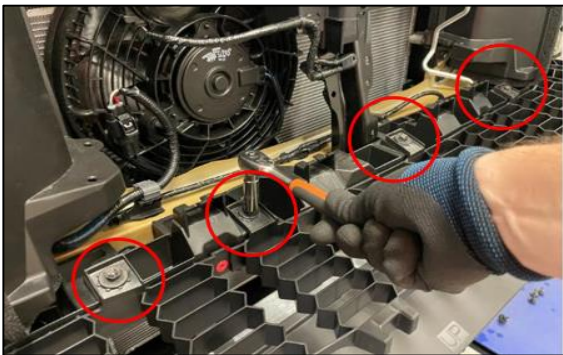
**18 Impact absorber Removal.**

Remove 6 x 10mm bolts. Remove impact absorber and discard

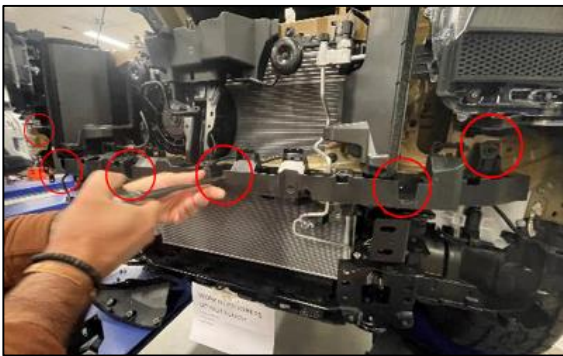
**19 Impact absorber Carrier Removal.**

Remove 6 x 10mm bolts. Release plastic trim clips to free carrier and discard.

**20 Crash Beam Removal.**

Remove crash beam cover by releasing the 8 x clips around the part.



FITTING PROCEDURE

21 Crash Beam Removal cont.**22** Crash Beam Removal

Remove 10 x 17mm bolts holding the beam to the chassis rails and set aside. Remove Crash Beam and discard

**23** Air Deflector removal.

Remove the side air deflectors by removing the 2 x plastic rivets and discard. Repeat process on other side

**24** Lower radiator guard removal.

Remove the OE radiator guard by removing the 4 x bolts.



FITTING PROCEDURE

**25 Bumper Outrigger Brackets.**

Remove the RH bumper outrigger bracket by removing the 2 x bolts and discard. Repeat process on other side.

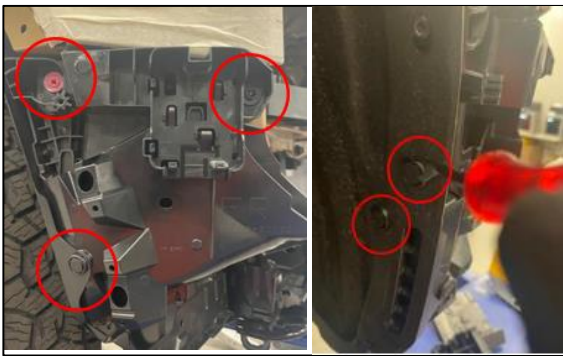
**26** Remove the outer bumper clips from the front guards. Detach the driver assist electrical connector**27** Remove the RH bumper side retainers by removing the 1 x 10mm bolt, 1 x pink plastic plastic rivet and 3 x plastic rivets.

Repeat this process on other side.

**28** Remove the outer bumper clips .

FITTING PROCEDURE

**29 Tow Points.**

Remove the RH OE tow points by removing the 2 x 17mm bolts and discard. Repeat the process on other side

**30 Vehicle Preparation Complete.** At this stage, the vehicle is now ready to commence the fitment of the bull bar.

Before proceeding to the next step, route the Wiring Harness (IC4TOPRIPDH TR) properly,

Referring to the **Wiring Harness (PK105P250G-WL) installation manual.**

**31 Parking Sensors**

Carefully remove the parking sensors and their wiring from the factory bumper, making sure to note the position and orientation of each sensor for accurate reinstallation

**32 Headlamp Washers.**

Remove assembly with one screw.

FITTING PROCEDURE

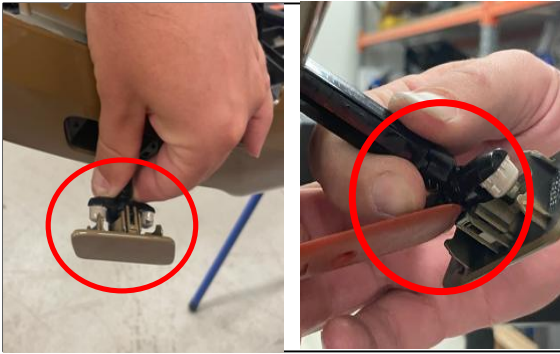
**33 Headlamp Washers cont.**

Pull washer out of bumper to expose the nozzles and washer cover clips.

Use pry tool to gently release the clip on the underside of the washer cover and set aside

**34 Headlamp Washers cont.**

Using a suitable tool, remove headlamp washer carrier from the painted area of the factory bumper. This is held to the bumper using double sided foam tape.

**35 Headlamp Washers cont.**

Using wax & grease remover and a plastic scraper, remove all traces of the OE foam tape and set aside.

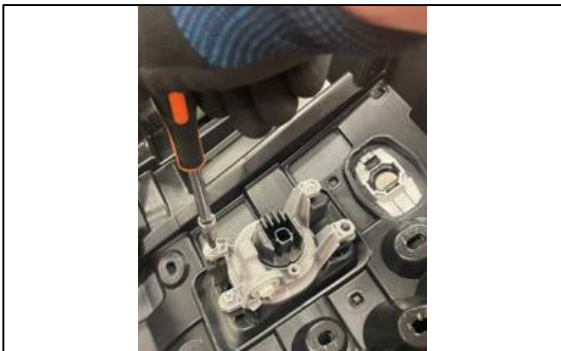
**36 Fog Lamps.**

Remove fog lights by removing 4 x PH2 screws.

FITTING PROCEDURE

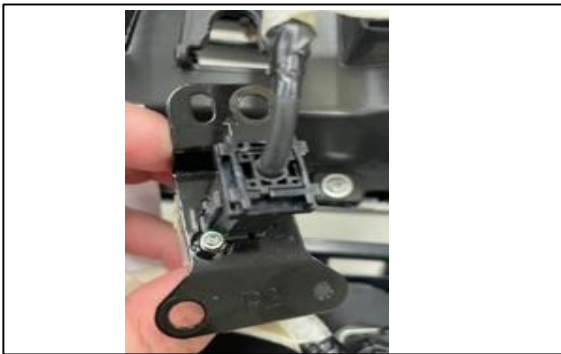
**37 Front View Camera.**

Disconnect plug from front view camera. Remove camera and bracket from OE bumper. Remove camera from bracket using T6 Torx drive and set screws aside.

**38 Chassis supports.**

Fit chassis support (Item 3) using 2x M12 x 100 mm bolts, 2x M12 Spring Washers, 2x 19mm OD Tubes and 2x M12 flat washers through the outside of the chassis rail. Secure to chassis rail using 4mm plate (Item 7) and 2x M12 flat washers and 2x M12 nuts.

Repeat on opposite side.

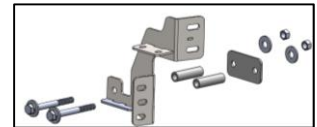
**39 Mounting Bracket Installation.**

Steps 40 and 41 should be combined into Step 39.

Using a second person or suitable lifting aid, fit Chassis mounting bracket to vehicle. Using 4x M12x30x1.25 bolts, 4x M12 spring washers and 4x M12 Flat washers, secure mounting bracket to vehicle.

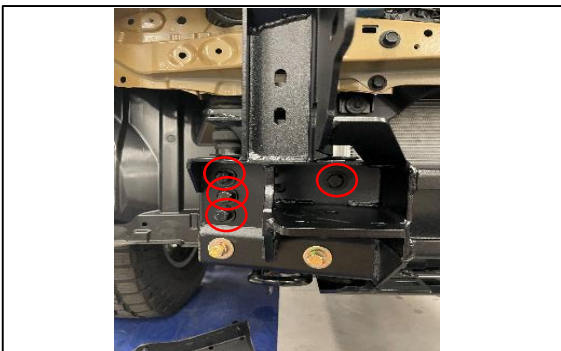
**40 Mounting Bracket Installation cont.**

Using 4x M10x35x1.5 bolts, 4x Spring Washers, 8x Flat Washers and 4x hex nuts, secure RH side of mount to the vehicle through the **FRONT** holes of the mount.

Repeat other side

FITTING PROCEDURE

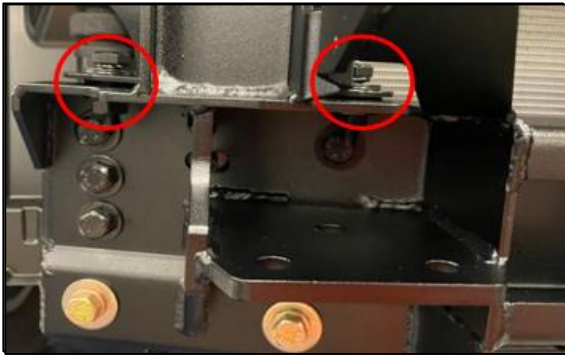
**41 Mounting Bracket Installation cont.**

Using 2x M10x35x1.5 Bolts, 2x M10 Spring Washers, 4x M10 Flat Washers and 2x M10 hex nuts, secure vertical holes of mounting bracket to the chassis of the vehicle.

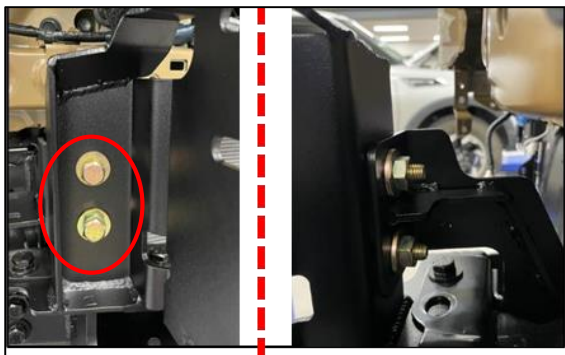
**42** Secure the points as shown in the picture using two M10 bolts (M10x35x1.5) along with spring washers, flat washers, and hex nuts.**43** Fit the Chassis Support Bottom (Item 5, 6) using two M12 bolts (OE) and two M10 bolts (M10x35x1.5) with EDP coating, along with spring washers, flat washers, and hex nuts. Ensure all components are properly tightened.

Repeat other side

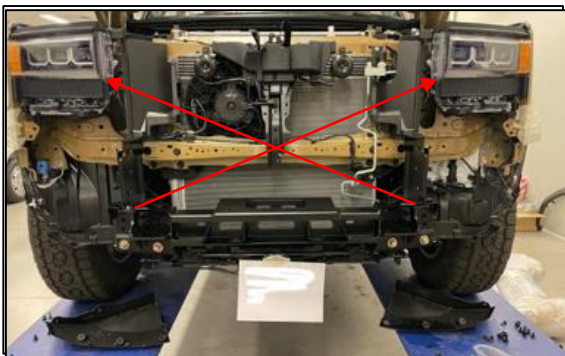
**44** Adjust the mounting bracket to be centered on the vehicle by measuring from the Headlamp to the mounting bracket. As shown in the picture.

FITTING PROCEDURE



45 Install the recovery point (Item 24, 25) using three M12 bolts (M12x50x1.5 Gr 10.9), along with spring washers, flat washers, and hex nuts. Ensure all components are securely tightened.

Repeat other side



46 Tighten all bolts as specified in the manual.

If a winch needs to be installed, do so at this stage before lifting the bullbar onto the vehicle.

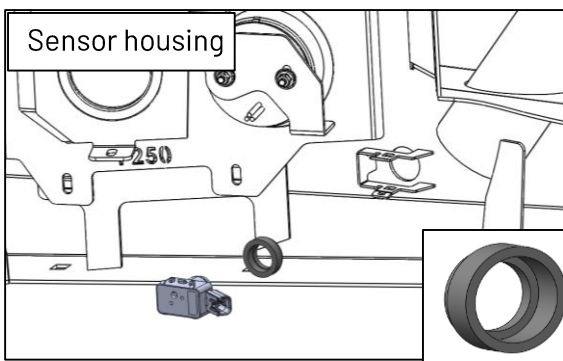

47 Insert the sensor housing onto the bull bar. Reinstall the parking sensors onto the bull bar, ensuring correct orientation and that each sensor "snaps" into place as shown.

Do this carefully.

Use pliers to widen the bracket, which will make it easier to insert the sensor.

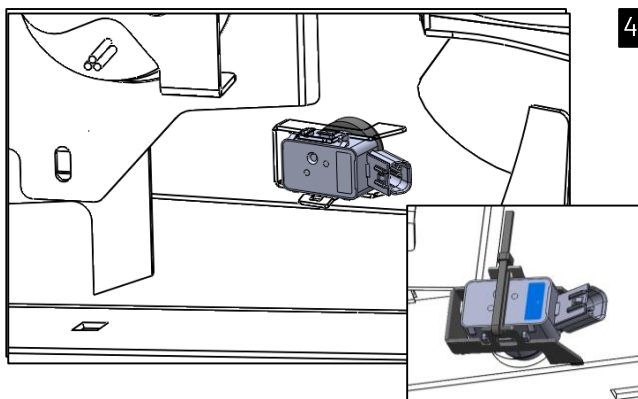
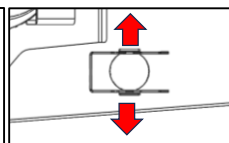

48

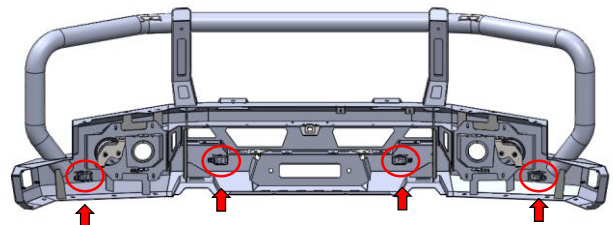

Lock the parking sensor into the sensor bracket of the bullbar using a cable tie at all points as shown in the picture..

FITTING PROCEDURE

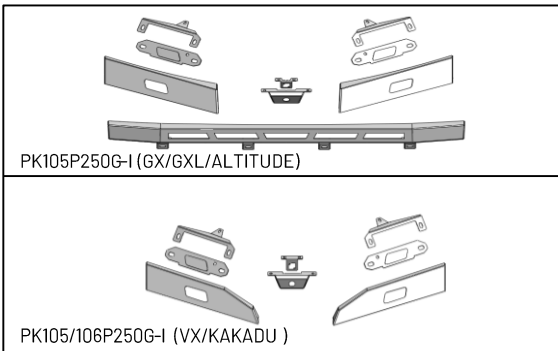

- 49** Front view camera and Infill fitment.
Using the fitting kit and Fitting instructions .
-PK105P250G-I (GX/GXL/ALTITUDE)
-PK105/106P250G-I (VX/KAKADU)

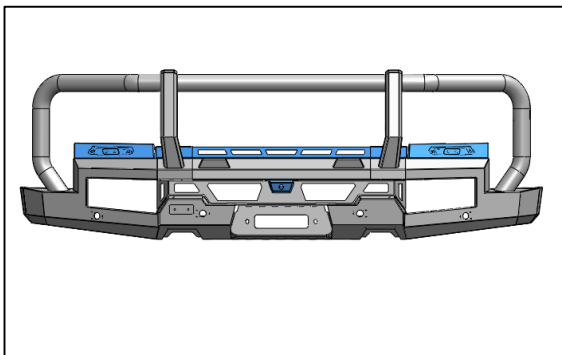

- 50** PIAK Genesis Loop Bar : Infill for GX/GXL/ALTITUDE Model
(Select according to your vehicle model)

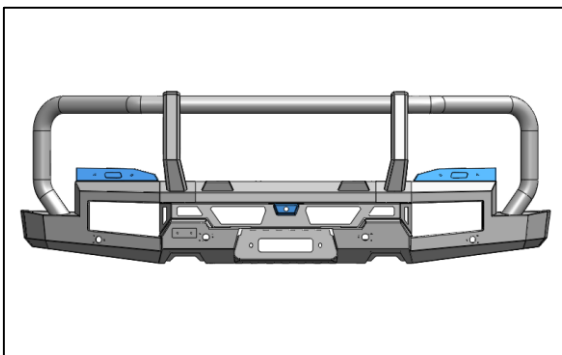

- 51** PIAK Genesis Loop Bar : Infill for VX/KAKADU Model
(Select according to your vehicle model)

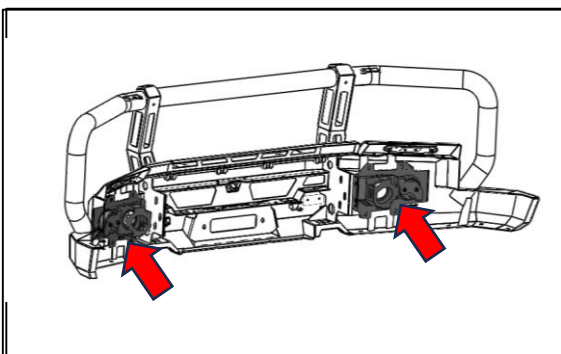

- 52** Attach the light frame to the bullbar .
Using the fitting kit and Fitting instructions .
-PKLB-LFFGOE-P250G

FITTING PROCEDURE

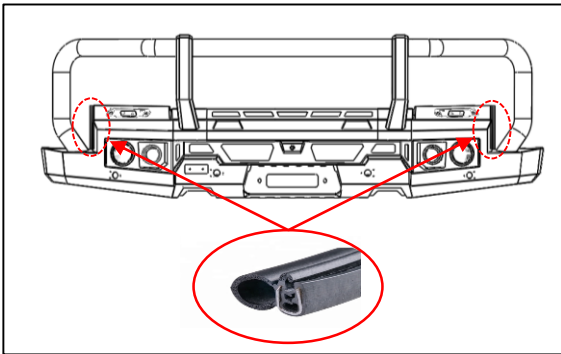

53 Insert pinchweld rubber seal Put the end RH&LH as shown.

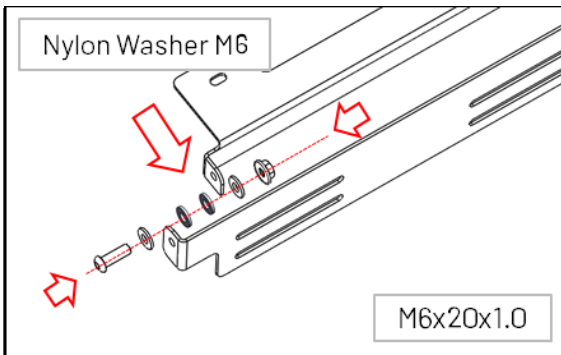

54 Assemble the license plate bracket using two M6 button head bolts, flat washers, nylon washers, and nyloc nuts as shown.

Do not fully tighten



55 Fit the assembled license plate bracket to the bull bar using M8 bolts (M8x20x1.25), spring washers, flat washers, and flange nuts.

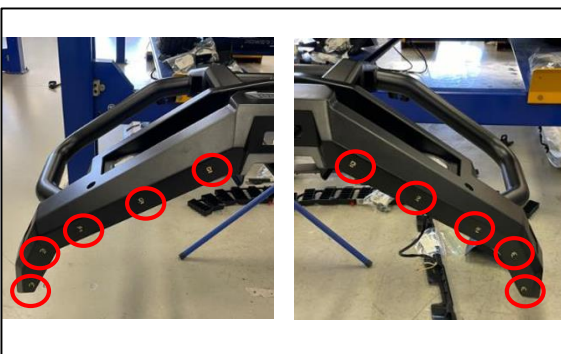

56 Insert ten M6x1.0x3T cage nuts into the designated slots on the bullbar.

FITTING PROCEDURE

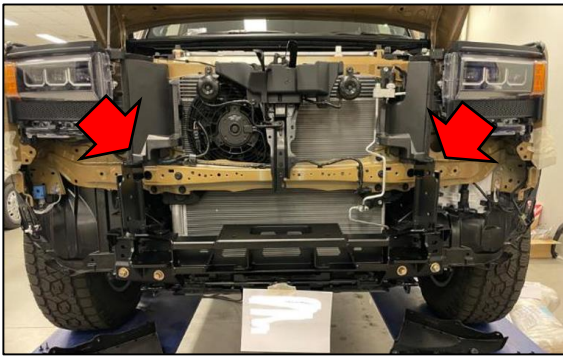

57 Secure the Front Grill Bracket to the vehicle at the points shown in the picture using M6 bolts (M6x20x1.0), spring washers, and flat washers.



58 Secure the Front Grill Bracket to the vehicle at the points shown in the picture using M6 bolts (M6x20x1.0), spring washers, and flat washers.

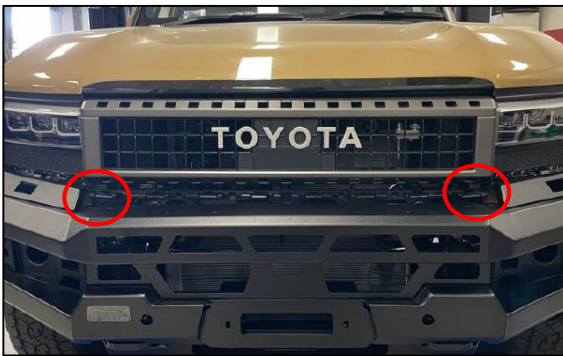
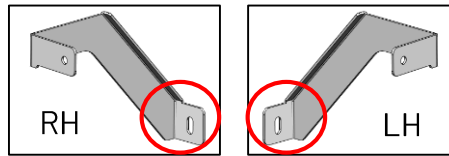

59 Use a 6 mm drill to make a hole at the bottom of the vehicle's Front Grill to attach the Front Grill to the Front Grill Bracket,
Using M6 bolts (M6x20x1.0), spring washers, flat washers, and flange nuts.

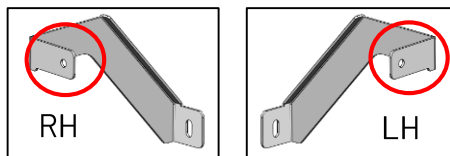

60 Lift the bull bar into position and align it with the chassis mounting holes
**** If a bull bar assist lift isn't available, it's advised that two people handle this task to prevent injury or damage to the vehicle and its parts.**

FITTING PROCEDURE



- 61** Lift the bull bar into position and align it with the chassis mounting holes. Secure it in place by using Six M12 bolts (M12x1.5x35), along with spring washers, flat washers, and hex nuts.



- 62** Align the bull bar so that there is a 20 mm gap between the car and the wing return of the bar, with the end of the wing in line with the wheel arch. Centralize the bull bar to the vehicle body, and lightly tighten the lower bolt on each side to allow for final adjustments to the correct position.

*Ensure all bolts are tightened according to the torque specifications provided on page 9.

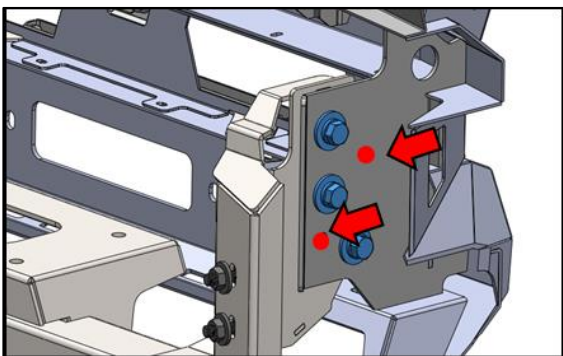

- 63** Mark the location of the bullbar holes on the mounting bracket as shown in the picture. This is in preparation for drilling the holes in the next step.

Use a drill to create two 10 mm holes through the mounting bracket. After drilling, deburr the edges and apply rustproof paint to protect the surface.

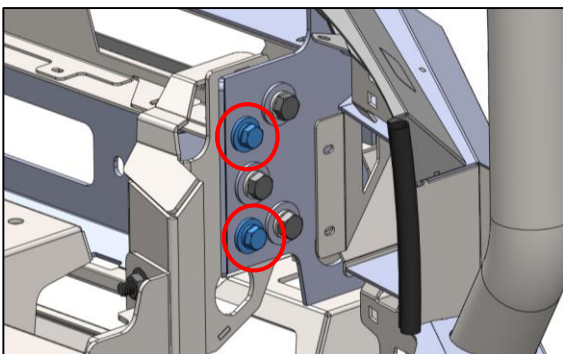

- 64** Use Four M10 bolts (M10x1.25x35), along with spring washers, 20 mm OD flat washers, and hex nuts.

*Ensure all bolts are tightened according to the torque specifications provided on page 9.

FITTING PROCEDURE



- 65** Connect the PIAK indicator and parker light first,
Referring to the **Wiring Harness (PK105P250G-WL)**
installation manual.



- 66** Install 2x M10x1.5 cage nuts into the mounting bracket.

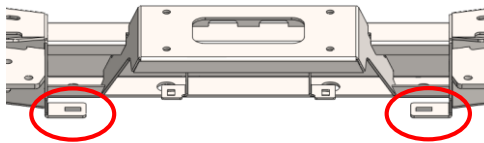

- 67** Install the Radiator Plate Bottom as follows :
- For the bottom position, use two spacers, hex bolts M8x30x1.25 , spring washers, and flat washers.
 - For the top position, use two hex bolts M10x30x1.5, spring washers, and flat washers.
- Refer to the position shown in the image.



- 68** Install 4x M8x1.25 cage nuts into the mounting bracket.
Bracket and Radiator Plate Bottom .

FITTING PROCEDURE



- 69** Install the Radiator Plate Top using four M8 bolts (M8x1.25x30), spring washers, and flat washers.

Refer to the position shown in the image.

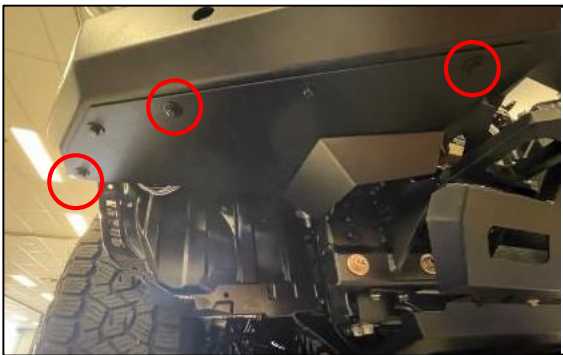

- 70** Attach the Side Plate to the bullbar using three M6 bolts (M6x1.0x20), spring washers, and flat washers.

Repeat for other side.



- 71** wheel arch liner trimming.

-Using the rear edge of the side plate as a guide, mark a line using a visible marker or masking tape across the front face of the wheel arch liner.

-Remove the side plate.

-Using a multi-tool or similar, cut along marked line on front face of wheel arch liner.



- 72** Refit Side plate using 5x M6x1.0.20 bolts, 5x spring washers and 5x flat washers.

Repeat for other side.

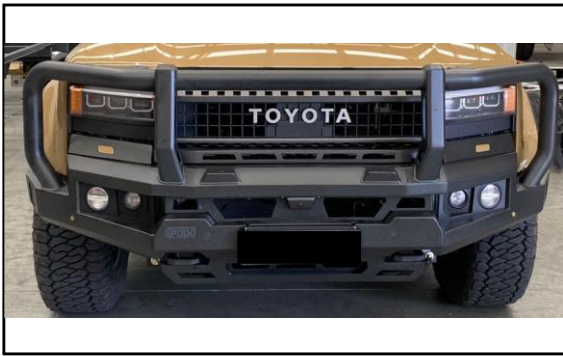
FITTING PROCEDURE

73 Remove any masking tape and refit the trimmed OE flares to the vehicle.

-Check all lamps function as intended.

-Check winch operation.

