

# Install Guide

## Front Lower Control Arm Rear Bush

### Subaru Various Models

**Nolathane®**

**Note:** These components must be fitted by a qualified person only, as per the manufacturers' service manual. Also, all relevant safety procedures are followed in addition to the following. Photos are an indication and may vary slightly in appearance from the actual product.

#### Kit Contents:

##### Single Offset Kit (451028)

- 1 x Bush 82002
- 1 x Bush 82096
- 2 x Washers

##### Double Offset Kit (451033)

- 2 x Bush 82096
- 2 x Washers

**Note:** Polyurethane bushes must be fitted to both sides of the vehicle.

1. Wheel align the vehicle before the job is started and note castor settings.
2. Raise vehicle evenly and safely support.
3. Proceed to remove front wheels. Next, unbolt sway bar link, ball joint and bushing bolt and nut. Remove control arms from vehicle.
4. Press out old bushing including steel shell using a hydraulic press and suitable press tools.
5. With reference to the diagrams (Figure 01), the kit number you have purchased and the settings required, align the bushings in the control arms, so that the hole of the bushing is positioned to give the desired castor results. Some later models (2016-on) that use pressed metal arms **note** bushing sits 10mm above the arm – refer to Figure 02.

**IMPORTANT!** For bushing 82002 (concentric hole bush) – bushing can only be pressed in one way. The inner tube has 2 IDs – ensure the larger ID is upwards. (Figure 03)

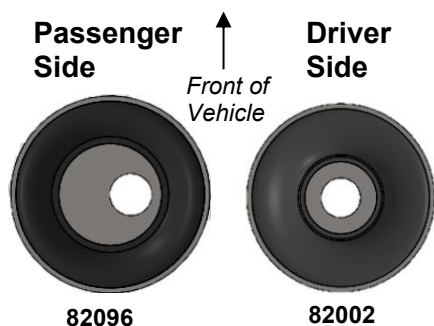

Kit (451028) - Single Offset  
To counteract a slight pull to the left.  
Passenger side castor increases and  
drivers side no castor change

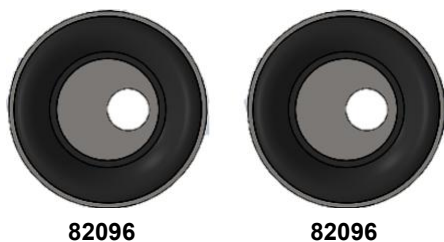

Kit (451033) – Double Offset  
To counteract a strong pull to the left.  
Passenger side castor increase and  
driver side castor decrease

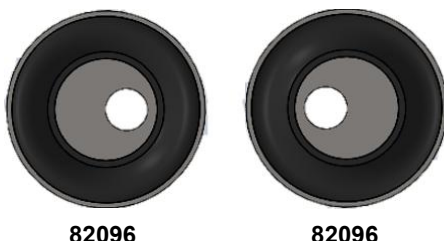

Kit (451033) – Double Offset  
Passenger and driver side increase  
castor

Figure 01: Bush Alignments

# Install Guide

## Front Lower Control Arm Rear Bush

### Subaru Various Models

**Nolathane®**



Figure 02: Later model (2016-on) control arm

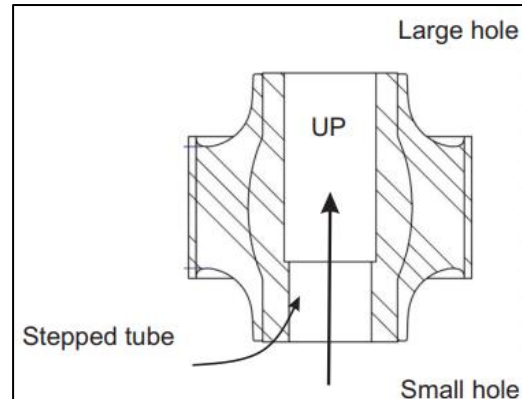

Figure 03: Direction to push bush 82002

6. Re-fit the arms to the vehicle. Place supplied washer on top of bushing. Refer to Figure 04.
7. Wheel alignment is recommended after install to correct any toe change.
8. Re-check all bolts after 100kms.

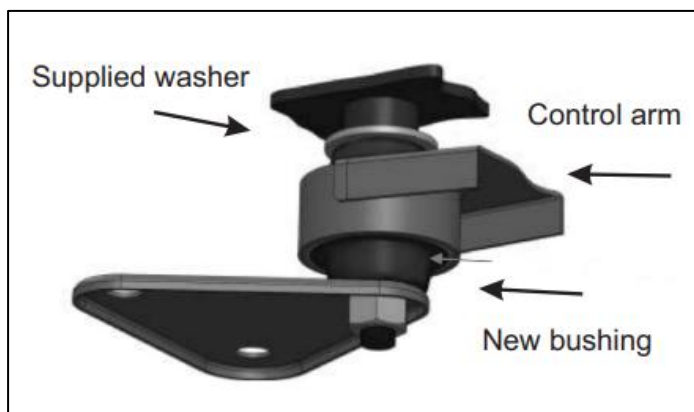

Figure 04: Washer location